

Printer Cutter

CJV30-60
CJV30-100
CJV30-130
CJV30-160

OPERATION MANUAL

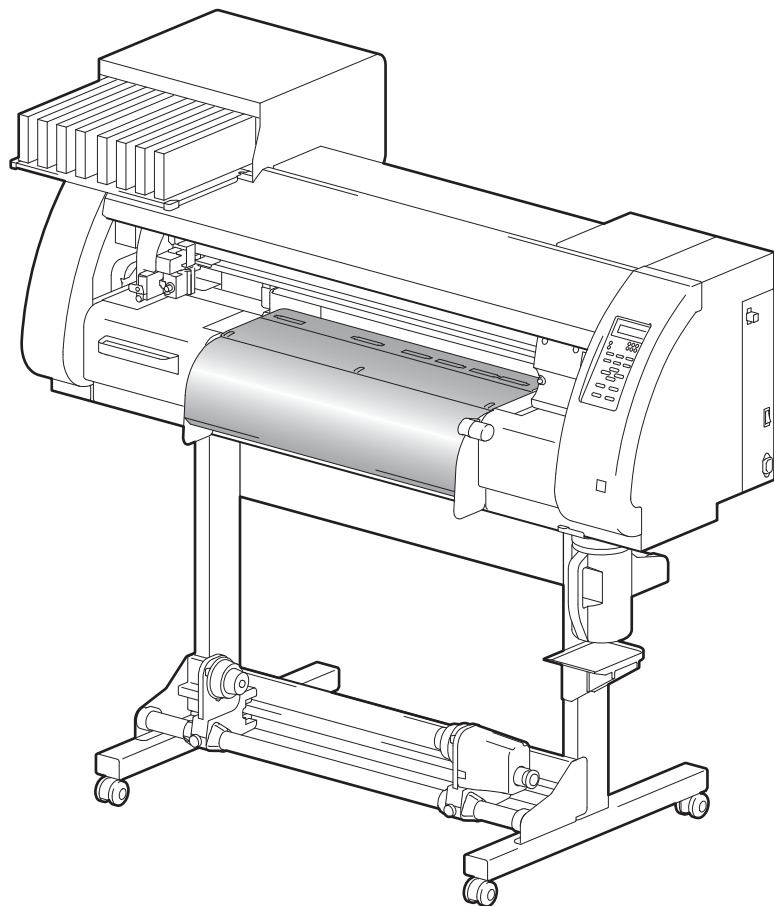

MIMAKI ENGINEERING CO., LTD.

URL: <http://www.mimaki.co.jp/>

D201873-14

Contents

Caution	vii
Caution	vii
Requests	vii
FCC Statement (USA)	vii
Interference to televisions and radios	vii
Foreword	viii
About This Operation manual	viii
Safety Precautions	ix
About Symbols	ix
How to Read this Manual	xiv

Chapter 1 Before Use

Moving This Machine	1-2
Where to Install This Machine	1-2
Working Environmental Temperature	1-2
Moving This Machine	1-3
Names of Parts and Functions	1-4
Front Side of the Machine	1-4
Rear/Sides	1-5
Operation Panel	1-6
Heater	1-7
Media Sensor	1-7
Carriage	1-8
Capping Station	1-9
Pinch Rollers and Grid Rollers	1-9
Pen-line Rubber	1-10
Media	1-11
Usable Sizes of Media	1-11
Caution in Handling of Media	1-11
Connecting Cables	1-12
Connecting USB2.0 Interface Cable	1-12
Connecting the Power Cable	1-13
Inserting Ink Cartridges	1-14
Caution in Handling of Ink Cartridges	1-15
Note on Silver and White ink of ES3 ink	1-15
Menu Mode	1-16

Chapter 2 Basic Operations

User Type for Printing	2-2
Settings That Can Be Registered in User Types	2-2
Using the Registered User Types	2-2
About Tool Conditions during Cutting	2-3
Tool Condition Types and Their Selection Method	2-3
Registering a Tool Condition	2-4

Improving Cutting Quality	2-6
Operation Flow	2-7
Turning the Power ON/OFF	2-8
Turning the Power ON	2-8
Turning the Power OFF	2-9
Installing Tools	2-10
When a Cutter Is Used	2-10
Exchanging Tool	2-13
How to Attach a Ballpoint pen	2-14
Setting a Medium	2-15
Adjusting the Head Height	2-15
Adjusting the Position of the Pinch Roller According to the State of a Medium	2-17
Roll Stopper	2-22
Maximum Print Area/Cut Area	2-23
Notes When Using Medium Holder	2-24
Setting a Roll Medium	2-25
Take-up Device	2-29
Setting a Leaf Medium	2-31
When Changing the Origin	2-33
Test Printing	2-35
Perform test printing with the normal test pattern	2-36
Perform test printing with the test pattern for checking white ink	2-37
Check warning of white nozzle status (Only when using SS21 white ink)	2-38
Head Cleaning	2-39
About head cleaning	2-39
Perform head cleaning depending on the test printing result	2-39
Perform spot color maintenance	2-40
Test Cutting	2-43
Preparing for the Heaters	2-44
Changing the Temperature Settings for the Heaters ..	2-44
Checking the Heater Temperature	2-45
Printing Data	2-46
Starting a Printing Operation	2-46
Stopping a Printing Operation	2-47
Deleting Received Data (Data Clear)	2-47
Data Cutting	2-48
Starting a Cutting Operation	2-48
Stopping Cutting in a While	2-48
Restarting a Cutting Operation	2-48
Stopping a Cutting Operation (Data Clear)	2-49
Removing the Cutter Unit Temporarily	2-49
Cutting a Medium	2-50

Chapter 3 Extended Functions – Printer –

About User Types	3-2
Registering All Printing Conditions Together (Type Registration)	3-2
How to Register User Types	3-2
Setting the Pinch Rollers	3-5
Recommended Setting for the Pinch Roller Pressure ..	3-5
Quantity of Pinch Rollers	3-5
Setting for the Pinch Rollers	3-6
Setting Media Correction	3-8
Setting Media Correction	3-8
If the Positions of Dots Shift... ..	3-10
Changing the Set Values of the Heaters	3-12
Changing the Temperature Settings for the Heaters ..	3-12
Adjustment to an Appropriate Temperature	3-14
When the Heater Temperature Does Not Reach the Preset One	3-15
Setting the Printing Method	3-16
Setting of Printing Quality	3-16
Setting a Scanning Direction	3-18
Setting Logical Seek	3-19
Setting for White-laying Printing	3-20
Setting Drying Time	3-21
Setting Priority Order	3-22
Setting Automatic Cleaning	3-24
Setting Cleaning during Printing	3-26
Other Settings	3-27
Copying the Set Contents	3-29
Initializing the Settings	3-30
Machine Settings	3-31
Setting the DEODORIZE FAN	3-31
Setting the DRYNESS FEED	3-32
Stamp Setting	3-33
Setting the Test Print Arrange	3-34
Change the operation condition of the room temperature	3-35
Extension of Ink Expiry Month	3-36
Switch Setting of Ink Supply Path	3-38

Chapter 4 Extended Functions – Cutting –

Setting the Pinch Rollers	4-2
Recommended Setting for the Pinch Roller Pressure and Number of Pinch Rollers	4-2
Quantity of Pinch Rollers	4-2
Setting for the Pinch Rollers	4-3
Cutting out Data with Register Marks	4-5
Flow of Cutting Data with Register Marks	4-5
Entering Register Mark Detection Mode	4-5
Notes on Inputting Data with Register Marks	4-6
Setting Register Mark Detection	4-11
Method of Detecting Register Marks	4-15
When Cutting Failed	4-17
Setting Automatic Cutting	4-22
Dividing and Cutting	4-23
Setting the Dividing and Cutting Function	4-23
Cutting Data by Using the Dividing and Cutting Function	4-25
Cutting with a Dotted Line	4-26
Changing the Order of Cutting	4-28
Setting the SORTING	4-29
Procedure for SORTING	4-31
Cutting out Data without Register Marks	4-32
Setting the P/C ORIGIN OFFSET	4-32
Setting the P/C SCALE ADJUST	4-34
Other Settings	4-36
Copying the Setting Contents	4-40
Initializing the Settings	4-41
Cutting Samples	4-42
Cutting a Medium into Multiple Pieces with a Certain Length	4-44
Perform Multiple Cuttings	4-46
Setting the Step Size	4-48
Other Convenient Functions	4-49
Medium Feeding	4-49
How to turn the heater OFF in the cutting mode	4-50

Chapter 5 Extended Functions – Common Settings –

Common Settings	5-2
Setting the Pinch Rollers	5-3
Setting a Cut Method	5-4
Setting CONFIRM. FEED	5-5
Setting the Expand Function	5-6
Setting Margins	5-8
Setting the RECEIVED DATA	5-9
Setting Time	5-10
Setting Units	5-11
Setting the MACHINE NAME	5-12
Setting a KEY BUZZER	5-13
Confirming Machine Information	5-14
Displaying the Information	5-14
Printing the List of Settings	5-16

Chapter 6 Maintenance

Maintenance	6-2
Precautions for Maintenance	6-2
About Cleaning Solution	6-2
Cleaning the Exterior Surfaces	6-3
Cleaning the Platen	6-3
Cleaning the Media Sensor and Register Mark Sensor	6-4
Cleaning the Medium Holder	6-4
Maintaining the Capping Station	6-5
Cleaning the Wiper and Cap	6-6
Replacing the Wiper	6-8
Before Washing the Ink Discharge Passage	6-9
Cleaning the Head Nozzles	6-11
Washing the Ink Discharge Passage (PUMP Tube Washing)	6-13
When the Machine Is Not Used for a Long Time (CUSTODY WASH)	6-14
Cleaning the Ink Head and the Area around It	6-16
When Nozzle Clogging Cannot Be Solved	6-18
FILL UP INK	6-18
DISCHARGE & WASH	6-19
Supplying the Machine with Ink Anew	6-21
Preventing Nozzle Clogging When the Power Is OFF	6-23
Setting the Refreshing Interval in the Sleep Mode	6-24
Setting the Tube Washing Interval in the Sleep Mode	6-25
Setting the Cleaning Interval in the Sleep Mode	6-26

Setting Regular Operations	6-27
Setting the Regular Wiping Operation during a Printing Operation	6-28
Setting the Refreshing Interval in the Standby Mode ..	6-30
Setting the Interval between Each PUMP Tube Washing Operation in the Standby Mode	6-31
Setting the Cleaning Interval in the Standby Mode	6-32
Other Maintenance Functions	6-33
Changing the Time When a Warning about Wiper Replacement Is Issued	6-33
Setting the Display of Media Residual	6-34
White Ink Maintenance Function	6-36
If a Waste Ink Tank Confirmation Message Appears ..	6-38
Changing the ink	6-42
Replacing the Cutter Blade	6-43
Replacing the Pinch Rollers	6-45
Replacing a Cutter Blade Not Included in the Accessories	6-46

Chapter 7 Troubleshooting

Troubleshooting	7-2
Image Quality Is Poor	7-4
Nozzle Is Clogged	7-4
Ink Cartridge Warning Appears	7-5
Warning/Error Messages	7-7
Warning Messages	7-7
Error Messages	7-10

Chapter 8 Appendix

Main Body Specifications	8-2
Printer Section Specifications	8-2
Cutter Section Specifications	8-2
Common Specifications	8-4
Ink Specifications	8-5
Warning Labels	8-6
Inquiry Sheet	8-8
Function Flowchart	8-9

Caution

DISCLAIMER OF WARRANTY: THIS LIMITED WARRANTY OF MIMAKI SHALL BE THE SOLE AND EXCLUSIVE WARRANTY AND IS IN LIEU OF ALL OTHER WARRANTIES, EXPRESS OR IMPLIED, INCLUDING, BUT NOT LIMITED TO, ANY IMPLIED WARRANTY OF MERCHANTABILITY OR FITNESS, AND MIMAKI NEITHER ASSUMES NOR AUTHORIZES DEALER TO ASSUME FOR IT ANY OTHER OBLIGATION OR LIABILITY OR MAKE ANY OTHER WARRANTY OR MAKE ANY OTHER WARRANTY IN CONNECTION WITH ANY PRODUCT WITHOUT MIMAKI'S PRIOR WRITTEN CONSENT. IN NO EVENT SHALL MIMAKI BE LIABLE FOR SPECIAL, INCIDENTAL OR CONSEQUENTIAL DAMAGES OR FOR LOSS OF PROFITS OF DEALER OR CUSTOMERS OF ANY PRODUCT.

Requests

- This Operation manual has been carefully prepared for your easy understanding. However, please do not hesitate to contact a distributor in your district or our office if you have any inquiry.
- Description contained in this Operation manual are subject to change without notice for improvement.

FCC Statement (USA)

This equipment has been tested and found to comply with the limits for a Class A digital device, pursuant to Part 15 of the FCC Rules. These limits are designed to provide reasonable protection against harmful interference when the equipment is operated in a commercial environment. This equipment generates, uses and can radiate radio frequency energy and, if not installed and used in accordance with the Operation manual, may cause harmful interference to radio communications.

Operation of this equipment in a residential area is likely to cause harmful interference in which case the user will be required to correct the interference at his own expense.

In the case where MIMAKI-recommended cable is not used for connection of this device, limits provided by FCC rules can be exceeded.

To prevent this, use of MIMAKI-recommended cable is essential for the connection of this printer.

Interference to televisions and radios

The product described in this manual generates high frequency when operating.

The product can interfere with radios and televisions if set up or commissioned under improper conditions.

The product is not guaranteed against any damage to specific-purpose radio and televisions.

The product's interference with your radio or television will be checked by turning on/off the power switch of the product.

In the event that the product is the cause of interference, try to eliminate it by taking one of the following corrective measures or taking some of them in combination.

- Change the orientation of the antenna of the television set or radio to find a position without reception difficulty.
- Separate the television set or radio from this product.
- Plug the power cord of this product into an outlet which is isolated from power circuits connected to the television set or radio.

Foreword

Thank you very much for your purchase of the MIMAKI Printer Cutter "CJV30-60/100/130/160".

The CJV30-60/100/130/160 is a Printer Cutter for high-quality printing enabled by solvent ink (4 or 6 colors) with a cutting function installed on it.

- 4-colors version : 2 each of Cyan, Magenta, Yellow and Black color ink cartridge are usable.
- 6-colors version : 1 each of Cyan, Magenta, Yellow, Black, Light cyan and Light magenta color ink cartridge (2 each of Cyan and Magenta only) are usable.
- 6-colors + White version : 1 each of Cyan, Magenta, Yellow, Black, Light cyan, Light magenta and White color ink cartridge (2 each of White only) are usable.
- 7-colors version : 1 each of Cyan, Magenta, Yellow, Black, Light cyan, Light magenta and Light black color ink cartridge (2 each of Light black only) are usable.
- 8-colors version : 1 each of Cyan, Magenta, Yellow, Black, Light cyan, Light magenta, White and Silver color ink cartridge are usable (available for the firmware V and later).

About This Operation manual

- This Operation manual describes the operation and maintenance of "CJV30-60/100/130/160" (hereafter referred to as "this machine").
- Please read and fully understand this Operation manual before putting the machine into service. It is also necessary to keep this Operation manual on hand.
- Make arrangements so that this manual is certainly delivered to the person in charge of the operation of this machine.
- This Operation manual has been carefully prepared for your easy understanding. However, please do not hesitate to contact a distributor in your district or our office if you have any inquiry.
- Description contained in this Operation manual are subject to change without notice for improvement.
- In the case where this Operation manual should be illegible due to destruction or lost by fire or breakage, purchase another copy of the Operation manual from our office.
- You can also download the latest manual from our website.









Unauthorized reproduction of this manual is strictly prohibited.
MIMAKI ENGINEERING Co., Ltd.
All Rights Reserved. Copyright

Safety Precautions









About Symbols

Symbols are used in this Operation manual for safe operation and for prevention of damage to the machine. One symbol is used for one caution. Please understand the meaning of each symbol and use this machine safely.

Symbols and Their Meanings

Meaning	
	Failure to observe the instructions given with this symbol can result in death or serious injuries to personnel. Be sure to read and observe the instructions for proper operation.
	Failure to observe the instructions given with this symbol can result in injuries to personnel or damage to property.
	Important notes in use of this machine are given with this symbol. Understand the notes thoroughly to operate the machine properly.
	Useful information is given with this symbol. Refer to the information to operate the machine properly.
	Indicates the reference page for related contents.
	The \triangle symbol indicates that the instructions must be observed as strictly as the CAUTION instructions (including DANGER and WARNING instructions). A sign representing a precaution (the sign shown at left warns of an electric shock hazard) is shown in the triangle.
	The \circ symbol indicates that the action shown is prohibited. A sign representing a prohibited action (the sign shown at left prohibits disassembly) is shown in or around the circle.
	The \bullet symbol indicates that the action shown must be taken without fail or the instructions must be observed without fail. A sign representing a particular instruction (the sign shown at left shows the necessity to unplug the cable from the wall outlet) is shown in the circle.

Warning and Caution for Use

 Warning	
Prohibition of Disassembly or Modification	Prohibition of Use in a Poorly Ventilated Room
 <ul style="list-style-type: none"> • Never disassemble or modify this machine or the ink cartridges. Disassembly or modification results in electric shocks or breakdown of the machine. 	 <ul style="list-style-type: none"> • Do not use the machine in a poorly ventilated room or a closed room. • Be sure to use the optional Drying ventilation unit when the machine is used in a poorly ventilated room or a closed room.
Prohibition of Use in a Damp Environment	
 <ul style="list-style-type: none"> • Avoid locating the machine in a damp environment. Do not splash water onto the machine. Use in such an environment can give rise to fire, electric shocks or breakdown of the machine. 	
Occurrence of an Abnormality	How to Handle a Power Cable
 <ul style="list-style-type: none"> • Use of the machine under an abnormal condition where it produces smoke or strange smell can result in fire or electric shocks. If such an abnormality is found, be sure to turn off the power switch immediately and unplug the cable from the wall outlet. Check first that the machine no longer produces smoke, and then contact your distributor or a sales office of MIMAKI for repair. Never repair your machine by yourself since it is very dangerous for you to do so. 	 <ul style="list-style-type: none"> • Use the attached power cable. • Take care not to damage, break or work upon the power cable. If a heavy material is placed on the power cable, or if it is heated or pulled, the power cable can break, thus resulting in fire or electric shocks.
About the Platen	About the Moving Parts
 <ul style="list-style-type: none"> • Take care that no dust or dirt sticks to platen heaters. Dust and dirt sticking heaters can cause fire. 	 <ul style="list-style-type: none"> • Do not allow your fingers or any part of your body to come close to the dangerous moving parts.
How to Handle Ink	
 <ul style="list-style-type: none"> • The ink used for this machine contains organic solvent. Since the ink is flammable, never use flame in or around the place where this machine is used. 	

Precautions for Use

 Caution	
About Power Supply <ul style="list-style-type: none"> Do not turn off the main power switch on the right side of this machine. 	Prohibition of Use in a Poorly Ventilated Room <ul style="list-style-type: none"> If you get ink in your eyes, immediately wash your eyes with a lot of clean water for at least 15 minutes. In doing so, also wash eyes to rinse ink away completely. Then, consult a doctor as soon as possible. If anyone drinks ink by mistake, keep him or her quiet and see a doctor immediately. Do not allow him or her to swallow the vomit. After that, contact the Poison Control Center. If you inhale a lot of vapor and feel bad, immediately move to a location of fresh air and then keep yourself warm and quiet. Then, consult a doctor as soon as possible.
About the Heaters <ul style="list-style-type: none"> Do not spill liquid on the platen as this may cause failure of the heater or firing. Do not touch platen heaters with bare hand while it is hot; otherwise, you can get burned. 	
<ul style="list-style-type: none"> When the machine is to be moved, wait until the heater temperature drops adequately. As a criterion, wait at least 30 minutes after you turn off the power to the heater. Moving the machine must be limited to on the same floor where there is no steps. When the machine is to be moved to any place other than on the same step-free floor, contact your distributor or a sales office of MIMAKI. 	
How to Handle Ink <ul style="list-style-type: none"> When cleaning the ink-station or the heads, make sure to wear the attached gloves. Further, when the solvent ink is used, it is necessary to wear the attached goggles. 	Caution about the Moving Parts <ul style="list-style-type: none"> Do not touch the rolling grid roller; otherwise, you may hurt your fingers or tear off your finger nails. Keep your head and hands away from any moving parts during a printing or cutting operation; otherwise, you may get your hair caught in the machine or get injured. Wear proper clothes. (Do not wear loose-fit clothes or accessories.) Also, bind a long hair. Each unit is automatically switched to in concert with the movement of printing or cutting. Do not make your face or hands near above the platen. Also, do not place a small object or a tool.
About Media <ul style="list-style-type: none"> Straighten the sheet of media, if significantly curled, before using it for printing. Heavily curled sheet affects the printing or cutting result. 	
About the Cutter <ul style="list-style-type: none"> Do not touch the cutter blade, which is very sharp. Do not shake or swing the cutter holder; otherwise, the blade may come off. 	



Cautions and Requests



Warning

<div style="display: flex; align-items: center; justify-content: center;"> <h3>Warning</h3> </div>		
How to Handle Ink Cartridges	About the Clamp Lever	
<ul style="list-style-type: none"> • Use the CJV30 genuine ink. Remember that the user shall be responsible for repairing any damage resulting from the use of ink other than the genuine one. • When any ink other than the CJV30 genuine ink is used, the machine will not operate for its own protection. • Do not use the CJV30 genuine ink for other printers because doing so may cause the printers to break down. • Never refill the ink cartridge with ink. Refilled ink cartridge can cause a trouble. Remember that MIMAKI assumes no responsibility for any damage caused by the use of the ink cartridge replenished with ink. • If the ink cartridge is moved from a cold place to a warm place, leave it in the room temperature for three hours or more before using it. • Open the ink cartridge just before installing it in the machine. If it is opened and left for an extended period of time, normal printing performance of the machine may not be ensured. • Make sure to store ink cartridges in a cool and dark place. • Store ink cartridges and the waste ink tank in a place that is out of the reach of children. • Be sure to thoroughly consume the ink in the ink cartridge, once it is opened, within three months. If an extended period of time has passed away after opening the cartridge tank, printing quality would be poor. • Neither pound the ink cartridge nor shake it violently, as doing so can cause leakage of ink. • Do not touch or stain the contacts of the ink cartridge, as doing so may cause damage to the print circuit board. • Waste ink is equivalent to waste oil of industrial waste. Request an industrial waste disposal company for disposal of waste ink. 	<ul style="list-style-type: none"> • Never open the front cover or raise the lever during printing. Opening the cover or raising the lever will abort printing. 	
	How to Handle Media	<ul style="list-style-type: none"> • Use media recommended by MIMAKI to ensure reliable, high-quality printing. • Set the heater temperature to meet the characteristics of the media. Set the temperature of the Pre-heater, Print heater and Post-heater according to the type and characteristics of the media used. Automatic temperature setting can be made on the operation panel by setting the profile on the dedicated RIP. For setting on the RIP, refer to the instruction manual for your RIP. • Pay attention to the expansion and contraction of the media. Do not use media immediately after unpacking. The media can be affected by the room temperature and humidity, and thus it may expand and contract. The media have to be left in the atmosphere in which they are to be used for 30 minutes or more after unpacked. • Do not use curled media. The use of curled media can not only cause a media jam but also affect print quality. Straighten the sheet of media, if significantly curled, before using it for printing. If a regular-sized coated sheet of media is rolled and stored, the coated side has to face outside.
	About Media and Dust	<ul style="list-style-type: none"> • Store media in a bag. Wiping off dust accumulated on media will adversely affect the media due to static electricity. • When leaving the workshop after the working hours, do not leave any media on the roll hanger. If any media is left on the roll hanger, it can get dusty.
Caution about Maintenance		
<ul style="list-style-type: none"> • It is strongly recommended to use the machine in a room that is not dusty. Set the Refresh level 2 or 3 when the machine is to be used in an unfavorable environment. (☞ P.3-34 "Setting of Refreshing") • Dust in the heads can also cause drops of ink to fall suddenly down on the media during printing. In such a case, be sure to clean up the heads. (☞ P.3-28 "Setting Auto cleaning") • When cleaning the ink-station or the heads, make sure to wear the attached gloves. Further, when the solvent ink is used, it is necessary to wear the attached goggles. • Perform wiping (removal of dust and paper powder) of the capping station and wiper frequently. 		
Periodic Replacement Parts		
<ul style="list-style-type: none"> • Some parts of this machine must be replaced with new ones periodically by service personnel. Be sure to make a contract with your distributor or dealer for after sale service to ensure the long life of your machine. 		

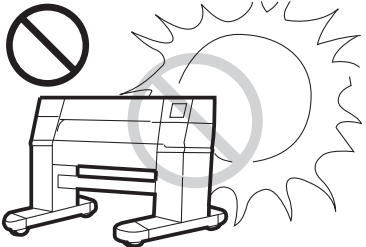
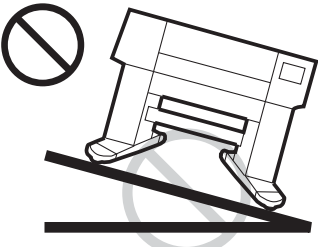
Cautions about Installation

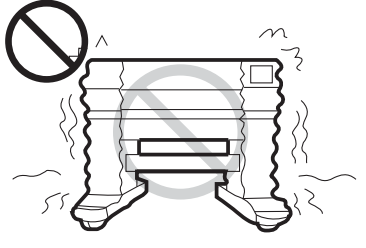
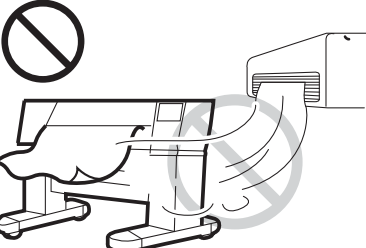
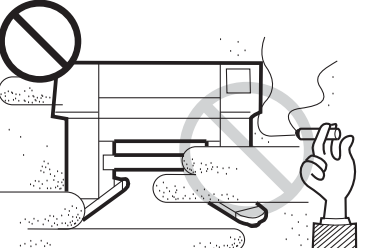
 Caution		
A place exposed to direct sunlight	On an inclined surface	A place where the temperature or humidity changes significantly
		 <ul style="list-style-type: none"> • Use the machine under the following environmental conditions: • Operating environment: 20 to 35°C 35 to 65% (Rh)
A place that vibrates	A place exposed to direct air flow from an air conditioner, etc.	Around a place where fire is used
		

How to Read this Manual

This indicates the description page of the printer mode or the cutting mode.

- P** : Printer mode
- C** : Cutting mode

Describes the function with text or illustration, and describes the contents such as the setting value or the notes to know beforehand.

The page title.

Cutting a Medium

There are two methods of cutting medium: automatic and manual.



- When cutting a medium, select a cutting method according to the size of the medium. (☞ P.5-4 "Setting a Cut Method")

Important!

- When a medium is cut, be careful that the printed side does not touch the floor or the printed side of other already cut media.
- When you use a take-up device, roll up the cut medium by using the switch of the take-up device.
- The set pinch roller (☞ P.2-17) detects the size of the medium and then determines the cutting method using it as a reference. If both ends of the medium are away from the pinch roller, note that the medium may remain uncut.



Automatic Cutting

After printing has been completed, the medium is cut off automatically.



- In order to activate the automatic cutting function, the setting for it needs to be configured. (The automatic cutting function is set to "OFF" as default.)
- The automatic cutting function needs to be set for printer function (☞ P.3-28) and cut function (☞ P.4-22) separately.
- When the automatic cutting function is "OFF", perform the operation in "Manual Cutting" described later to cut a medium.

- 1 When printing has been completed, the medium is cut automatically.

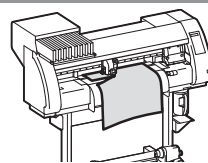

Manual Cutting

By using the keys on the operation panel, you can cut the medium at any position.

- 1 Press the key in LOCAL.
 - LOCAL changes to the origin setting mode.
 - By pressing , feed the medium to the cutting position.

ORIGIN SET UP
0.0 ----

- 2 Press the **FUNCTION** key.

MEDIA CUT <EN

- 3 Press the **ENTER** key.

- The medium is cut.
- When the cutting has been completed, the current mode returns to LOCAL.

MEDIA CUTTING
PLEASE WAIT

Number of an operation sequence.

Indicates a screen display.

2-50

Page number
(Section 2, Page 50)

Shows buttons in text,
surrounded by .



Chapter 1

Before Use



This chapter

describes the items required to understand before use, such as the name of each part of the machine or the installation procedures.

Moving This Machine	1-2	Media	1-11
Where to Install This Machine	1-2	Usable Sizes of Media	1-11
Working Environmental Temperature	1-2	Caution in Handling of Media	1-11
Moving This Machine	1-3	Connecting Cables	1-12
Names of Parts and Functions	1-4	Connecting USB2.0 Interface Cable	1-12
Front Side of the Machine	1-4	Connecting the Power Cable	1-13
Rear/Sides	1-5	Inserting Ink Cartridges	1-14
Operation Panel	1-6	Caution in Handling of Ink Cartridges	1-15
Heater	1-7	Note on Silver and White ink of ES3 ink	1-15
Media Sensor	1-7	Menu Mode	1-16
Carriage	1-8		
Capping Station	1-9		
Pinch Rollers and Grid Rollers	1-9		
Pen-line Rubber	1-10		

Moving This Machine

Where to Install This Machine

Secure a suitable installation space before assembling this machine.

The place of installation must have enough space for not only this machine itself, but also for the printing and cutting operation.

Model	Width	Depth	Height	Gross weight
CJV30-60	1,524 mm	739 mm	1,424 mm	110 kg
CJV30-100	1,934 mm	739 mm	1,424 mm	130 kg
CJV30-130	2,289 mm	739 mm	1,424 mm	145 kg
CJV30-160	2,538 mm	739 mm	1,424 mm	160 kg

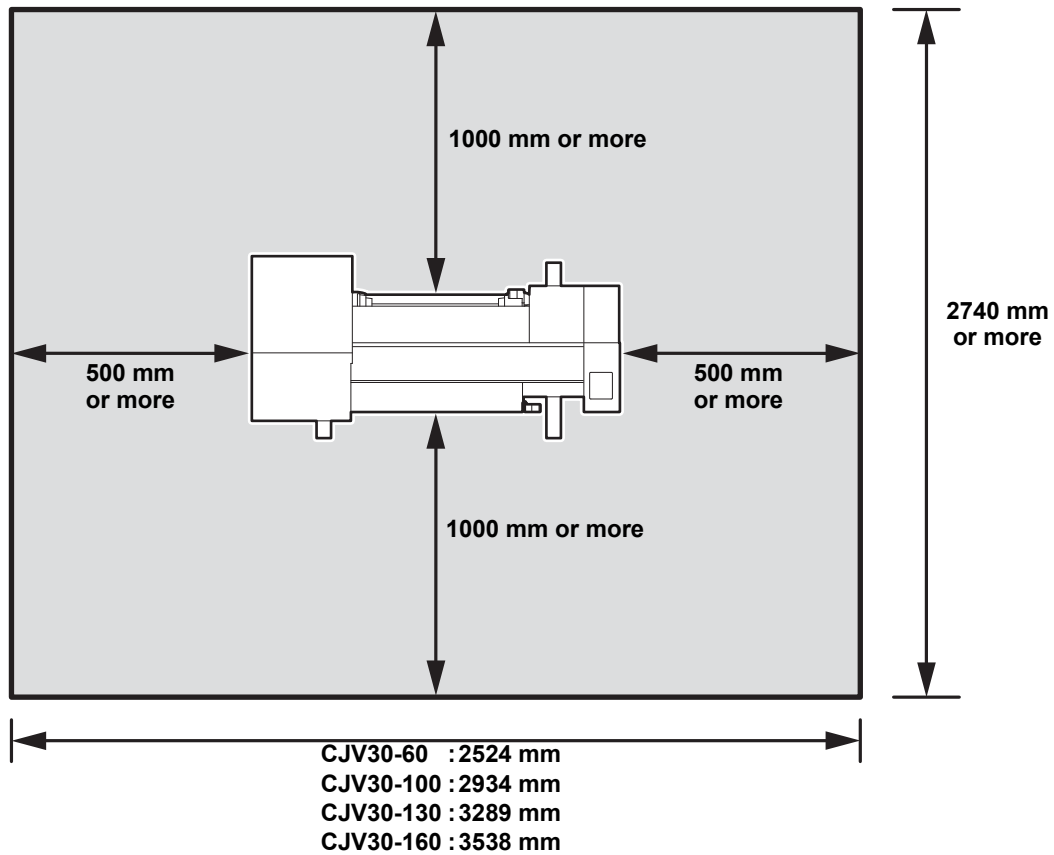

Working Environmental Temperature

Use this machine in an environment of 20 to 35°C to ensure reliable printing.

The heater temperature may not reach the set value, depending on the ambient temperature.

Moving This Machine



1

Before Use

Move this machine according to the following steps when this machine needs to be moved on the same step-free floor.

Important!

- When the machine is moved to any place other than on the same step-free floor, contact your distributor or our service office.
If you move it by yourself, failure or damage may occur.
Be sure to request your distributor or our service office to move this machine.



- When moving this machine, take care that it does not receive a significant impact.
- Be sure to lock the casters after moving of this machine.

1

Unlock the casters.

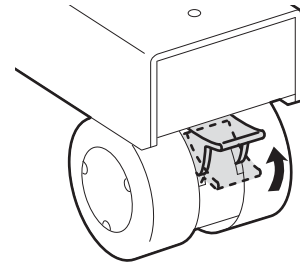

2

Move this machine as shown in the figure.

- For safety, be sure to operate it with 4 people or more.
- Do not push the cover to move this machine since the cover may be broken.

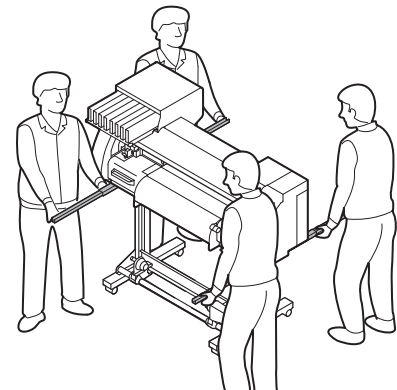

3

Lock the casters.

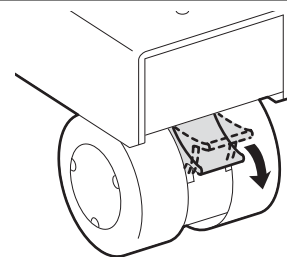

Names of Parts and Functions

Front Side of the Machine



Maintenance cover

Open the cover when carrying out maintenance. Even when the power switch is OFF, keep the cover closed.

Carriage (cutter unit)

Moves the cutter head unit from side to side.

Ink cartridge

The cartridge contains ink for each color.

Cartridge protection cover

This cover prevents an injury to the operator or the breakage of the machine caused by the protrusion of the 440-cc cartridge. (It is located under the ink cartridge.)

Clamp lever (front)

Moves the pinch rollers up and down to hold or release the media.

Carriage (printer unit)

Moves the print head unit from side to side.

Operation panel

This panel has operation keys for configuring the settings needed for this machine and a display for showing the items to operate.

Power switch*1

Turns ON/OFF the power to the machine.

Waste ink tank

Waste ink gathers in this tank.

Stand

Supports the main body of the machine. It is provided with casters that are used to move this machine.

Take-up device

Automatically winds up the roll media printed.

Tool tray

A tool tray is provided so that you can put the small tools such as cutter knives, pens, etc. on it.

Platen

The printed media is printed out, sliding on the platen. Three heaters are installed inside the platen.

Print heater/Post-heater

Fixes and dries the ink on the currently produced print. (Located inside the platen)

*1 : The power switch under the operation panel lights up in green when the power is turned ON, and blinks when the power switch is turned OFF. The ink clogging prevention function is regularly performed even when the power switch is turned OFF with the main power switch (☞ P.1-5) kept ON. (Sleep function ☞ P.6-23)

Rear/Sides

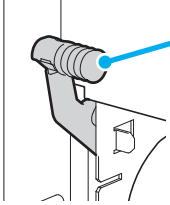

Clamp lever (rear)
Interlocks with the clamp lever in the front of this machine.

Cleaning solution cartridge
Set a dedicated Washings cartridge (optional).

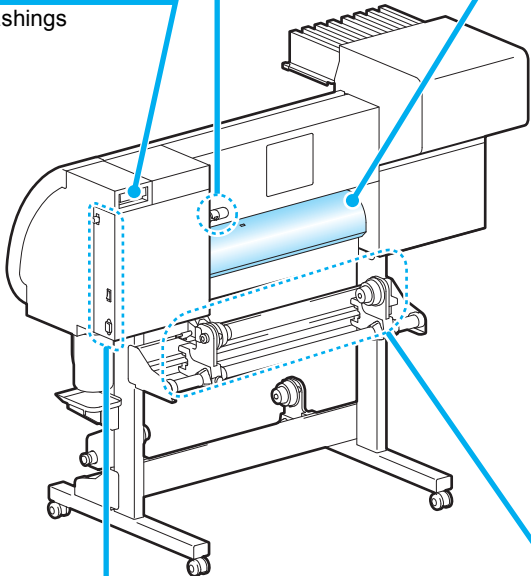

Pre-heater
Preheats the media before printing. (Located inside the platen)

Roll holders
Holds a media by inserting it into the right and left ends of the core of the roll media. Roll holders are available for the 2 inches and 3 inches core of the roll media.

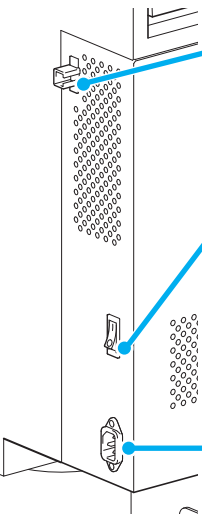

USB connector
This is USB2.0 interface connector.

Main power switch
Turns ON/OFF the main power for this machine. Leave the main power turned ON to prevent ink clogging.

AC inlet
Connect the power cable to the AC inlet.

Operation Panel



Display

Displays the status of the machine, set items and errors.

MODE CHANGE key

Use this key to switch the modes between print mode (PRINT MODE lamp is ON) and cut mode (CUT MODE lamp is ON).

USER TYPE/TOOL key

Use this key to select a user type in print mode or to select a tool condition in cut mode.

CLEANING/FEED key

Use this key to execute head cleaning when ink clogging occurs in print mode, or to feed the media in cut mode.

DATA CLEAR key

Deletes the data that has been received.

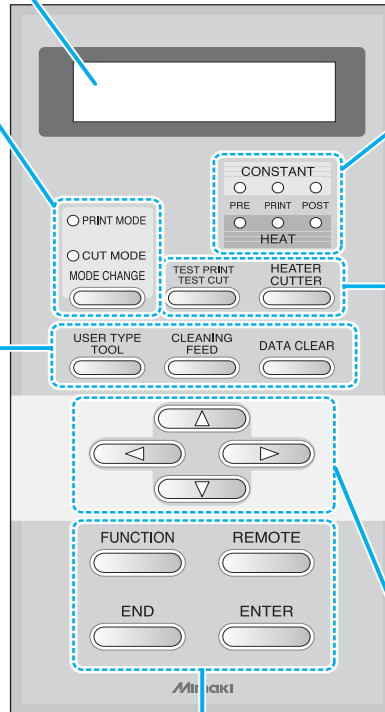

CONSTANT lamp

Lights up in green when the heater temperature reaches the set temperature.

HEAT lamp

Lights up in orange during heating up of the heater.

TEST PRINT/TEST CUT key

Use this key to check the prints for errors in print mode and cut mode.

HEATER/CUTTER key

Use this key to set the temperatures for the Pre-heater, Print heater and Post-heater or check the current temperature of the platen.

Jog key

Use these keys to shift the carriage or the media in [LOCAL]. Also use them to select an item from printing conditions.

FUNCTION key

Use this key to display the function setting menu.

REMOTE key

Use this key to switch between [LOCAL] and [REMOTE].

END key

Cancels the last input value or returns the setting menu to the immediate higher level of the hierarchy.

ENTER key

Registers the last input value as the setting value or goes to the immediate lower level of the hierarchy.

Heater

Pre-heater/Print heater/Post-heater are equipped on the platen.

The Pre-heater is used for pre-heating of the media prior to printing to prevent rapid changes in temperature. The Print-heater improves the image quality in printing. The Post-heater dries ink after printing.



- While the heater is on, the platen is very hot. When the front cover (Optional) is to be opened or media is to be replaced, lower the heater temperatures and wait until the platen temperature drops; otherwise, you can get burned.
- When the media is to be replaced with a thin one, lower the heater temperatures and wait until the platen temperature drops adequately. Setting a thin sheet of media while the platen is hot may cause the media to stick to the platen or cause wrinkling or curling of the media.

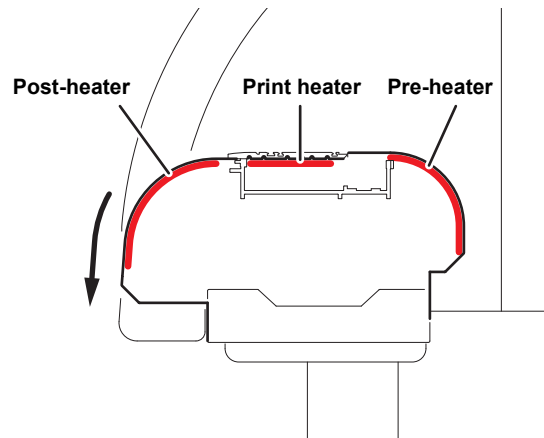
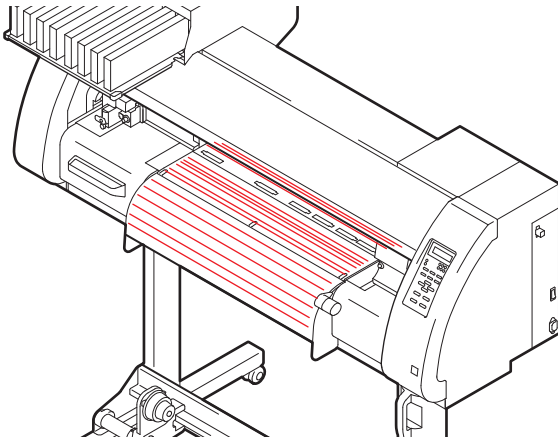

Media Sensor

The media sensor detects the presence of the media and the media length.

This machine has a media sensor on the platen (in the rear).



- Set the media so that the media sensor located in the rear of the platen is covered with the media without fail. The media cannot be detected unless it is placed over the sensor.

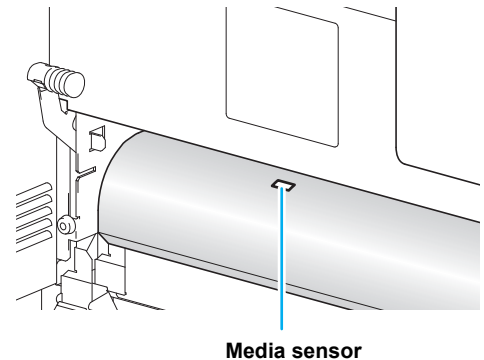

Carriage

The carriage consists of the printer unit and the cutter unit.

Cutter unit

The cutter unit is used for cutting and printing with a pen.

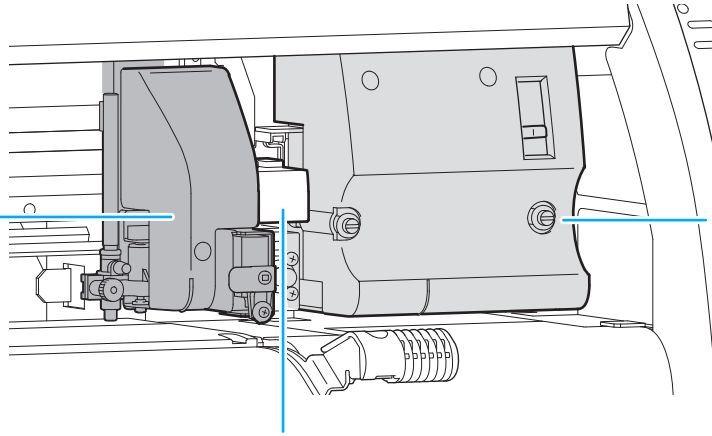

Printer unit

The printer unit is used for printing.

Conjunct unit *1

In concert with the data sent from a computer or the movement of the main body, switching is performed between printer unit and cutter unit.

*1 When switching the conjunct unit to the printer unit with the cutter unit placed on the platen, the movement speed of the first 20cm becomes slow to avoid injury from the cutter unit.

Printer Unit

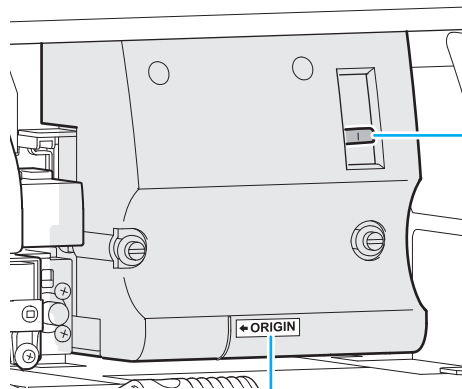

Height-adjusting lever

A height-adjusting lever is provided to adjust the height of the Head in 2 stages according to the thickness of media. (P.2-15)

ORIGIN mark

Use the ORIGIN mark as a marker for the origin position when using the printer unit

Cutter Unit

Tool holder

Attach a tool for cutting media to the tool holder.

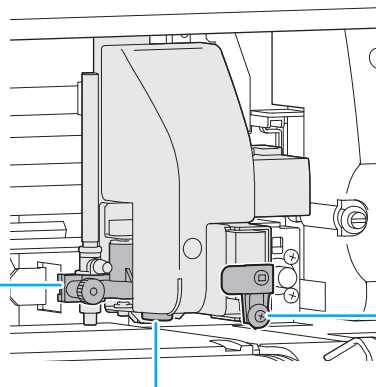

Cutter

The cutter is used for cutting off media.

Light pointer

The light pointer is used for detecting the register mark.

Capping Station



- Be sure to wear the attached goggles in cleaning within the capping station to protect your eyes against ink.

The capping station consists of the ink caps, the wiper for cleaning the heads, etc.

The ink caps prevent the nozzles in the ink heads from drying up.

The wiper cleans the nozzles in the heads.

The wiper is consumable. If the wiper is deformed or the media is stained, replace the wiper with a new one. (👉 P.6-8)

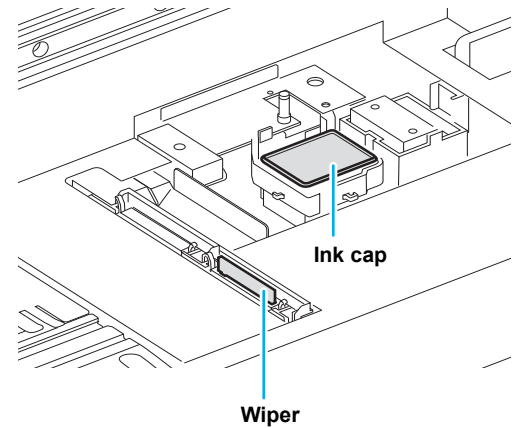

1

Before Use

Pinch Rollers and Grid Rollers

This machine retains the media with the pinch rollers and the grid rollers.

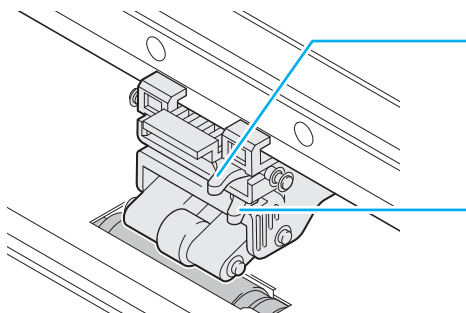

Pressure mode switching lever

This lever changes the pressure to hold the media. For details on pressure setting, see P.3-6, P.4-3 "Setting for the Pinch Rollers".

ON/OFF switching lever

This lever switches the pinch rollers ON/OFF. For details on the setting, see P.3-6, P.4-3 "Setting for the Pinch Rollers".



- Do not switch manually the pressure mode switching lever and ON/OFF switching lever. Doing so may cause malfunctions to occur.

Pen-line Rubber

Cutting and printing with a pen are performed on the pen line rubber.

If you want to perform dotted line cutting, follow the steps below.

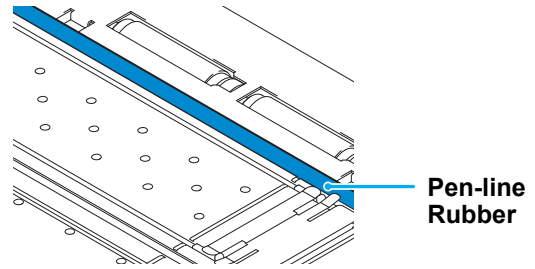

When performing dotted line cutting:

1 Remove the pen-line rubber.

- (1) Insert a flathead screwdriver or equivalent tool into the gap between the left end of the pen-line rubber and the platen.
- (2) Raise the pen-line rubber.

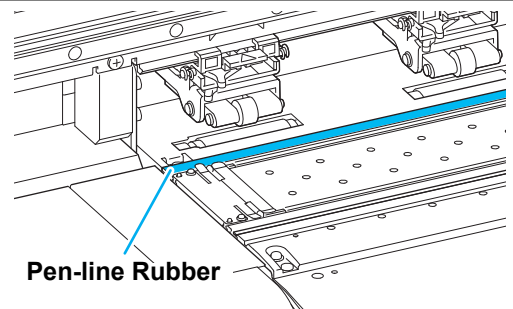

2 Install the pen-line sponge.

- (1) Align the right end of the pen-line sponge with the right end of the platen.
- (2) Install the pen-line sponge.

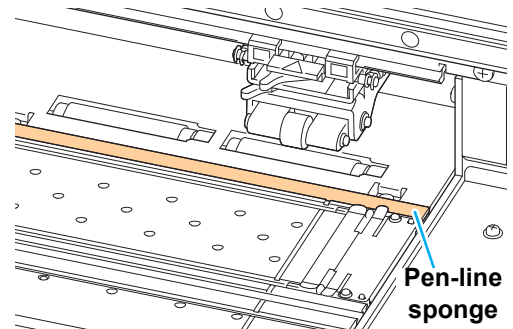

Important!

Be careful of the following when installing the pen-line rubber.

- When installing the pen-line rubber, make sure to push it into the slot softly and avoid stretching it forcibly.
- If pen line rubber is stretched forcibly, the edge of the pen line comes off and may decline the cutting quality.
- Store the replaced pen line.



- The pen-line sponge and pen-line sponge are consumable. Replace it with a new one if necessary.

Usable media sizes and notes for handling are described.



Before Use

Usable Sizes of Media

Model		CJV30-60	CJV30-100	CJV30-130	CJV30-160
Type of recommended media	When printing	Tarpaulin / FF(Flexible Face) / Polyvinyl chloride film / MS Chloroethene / MS Tarpaulin			
	When cutting	MS Chloroethene / Chloroethene sheet / Fluorescent sheet / Reflection sheet			
Maximum width		620 mm	1,030 mm	1,371 mm	1,620 mm
Minimum width		100 mm	100 mm	100 mm	100 mm
Maximum printing / cut width		610 mm	1,020 mm	1,361 mm	1,610 mm
Roll media	Thickness	1.0 mm or less			
	Roll outside diameter	φ180 mm or less			
	Roll weight	25 kg or less			
	Roll inside diameter	2 or 3 inches			
	Print side	Side facing outward			
	Roll end treatment	The roll end is gently fixed to the core with weak-adhesive tape or weak glue for easy removal.			

Caution in Handling of Media

Pay attention to the followings for handling of media.



- **Use media recommended by MIMAKI.**
Such media ensures reliable and high-quality printing.
- **Set the heater temperature to meet the characteristics of the media.**
Set the temperature of the Pre-heater and Print heater according to the type and characteristics of the media used. Automatic temperature setting can be executed on the operation panel by setting the profile on the dedicated RIP. For the setting on the RIP, see the instruction manual for your RIP.
- **Pay attention to the expansion and contraction of the media.**
Do not use media immediately after unpacking them. The media can be affected by the room temperature and humidity, and thus it may expand and contract. The media have to be left for 30 minutes or more in the open air in the environment in which they are to be used after being unpacked.
- **Do not use curled media.**
The use of curled media can cause a media jam. If a regular-sized coated sheet of media is rolled and stored, the coated side has to face outside.

Connecting Cables

Connecting USB2.0 Interface Cable

Connect the PC and this machine with the USB2.0 interface cable.



- Your application must be compatible with USB 2.0.
- Contact a RIP maker near your location or our office when the USB2.0 interface is not attached to the PC.

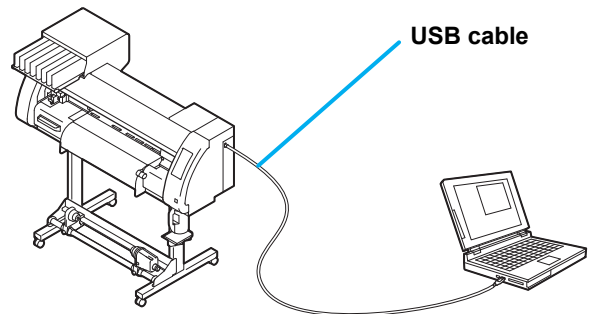

Notes on USB 2.0 Interface



- Your application must be compatible with USB 2.0.

● When two or more CJV30 machines are connected to one personal computer

Set the different "MACHINE NAME" for each connected CJV30. (☞ P.5-12)

When two or more CJV30 machines are connected to one personal computer, the personal computer may not recognize all the CJV30 machines normally.

Reconnect the unrecognized CJV30 machine to another USB port, if available, and check to see if it is recognized. If the CJV30 machine is not recognized by the newly connected USB port, use USB 2.0 repeater cables available on the market.

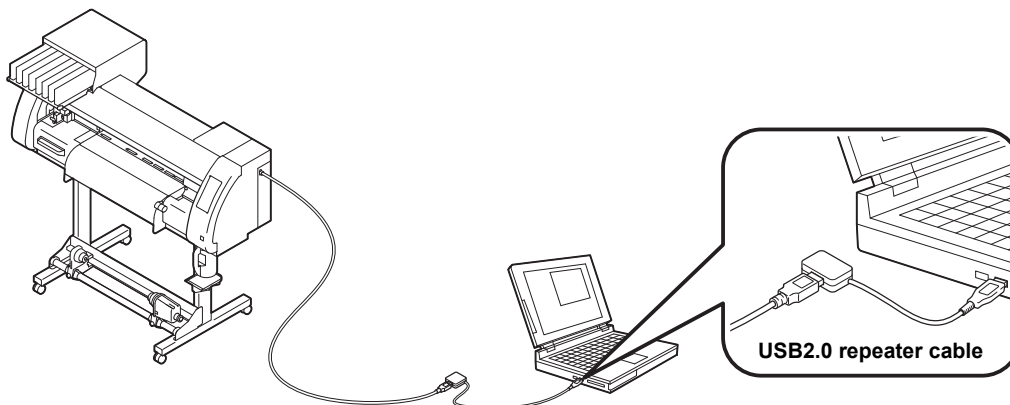

● Notes on peripheral devices in USB high speed mode

When a peripheral device (USB memory or USB HDD) to be operated in USB high speed mode is connected to the same personal computer that a CJV30 machine is connected to, the USB device may not be recognized.

When CJV30 is connected to the personal computer to which an external HDD is connected via USB, the speed of data output to CJV30 may drop. That can cause the head unit to stop temporarily at the right or left end during printing.

● **Removing USB memory**

If a USB memory module is inserted in the personal computer to which a CJV30 machine is connected, click "Stop" in the "Safely Remove Hardware" window by following the instructions given there first and then remove the module.

Leaving a USB memory module inserted can cause [ERROR 10 COMMAND ERROR]. Copy the data onto the hard disk before outputting it for printing.

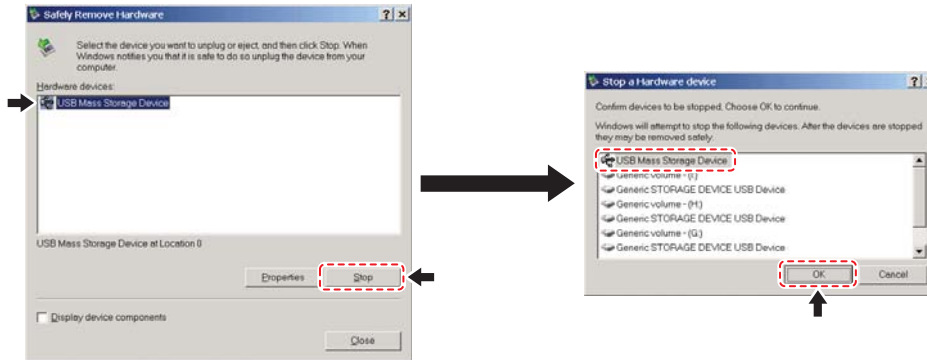

Connecting the Power Cable

1 Insert the power cable into an inlet of the machine.

2 Secure a cable band.
 • Secure the cable with the cable band attached to this machine.

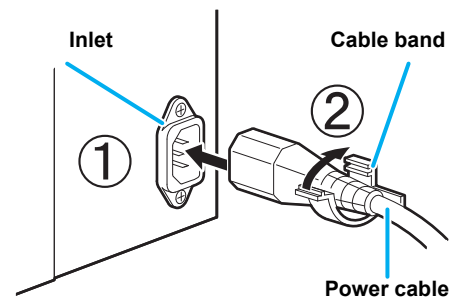

3 Insert the power plug into a plug socket.

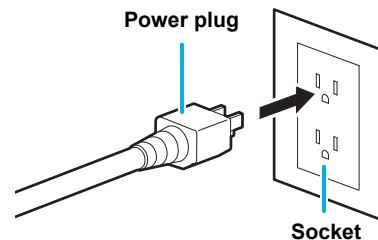

• Do not use any power cables other than the attached power cable.



• Be sure to connect the power cable to the outlet near this machine, and make sure that the power cable can be easily removed.
 • Connect the power cable to the grounded outlet. Otherwise, it may result in fire or an electric shock.

Inserting Ink Cartridges

Insert ink cartridges.

1 Shake the ink cartridge as shown on the right.

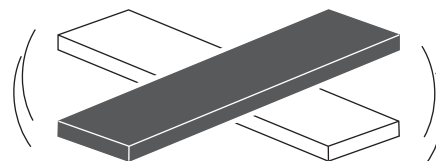

2 Insert the ink cartridge.

- Insert the ink cartridge lengthwise with the surface having IC chips pointing to the left side.
- Colors are displayed on the display as follows.

Black: K, Cyan: C, Magenta: M, Yellow: Y, Light cyan: c,
Light magenta: m, White: W, Silver: S, Light black: k

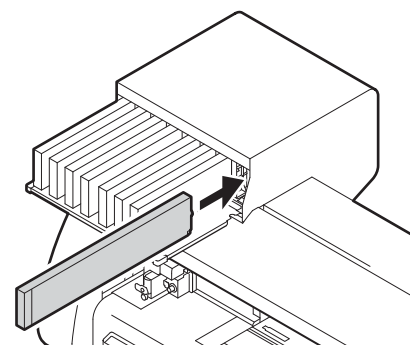

Changing an Ink Cartridge

Perform as follows when [INK END] or [NEAR END] is displayed on the display.

● When [INK END] is displayed

- (1) Pull out the ink cartridge to be replaced.
- (2) Insert a new ink cartridge, paying attention to the direction of IC chip.

● When [NEAR END] is displayed

There is a little ink left. Though printing can be continued even if it is displayed, it is recommended to replace the ink cartridge as soon as possible to avoid running out of ink during printing.

Important!

- While [NEAR END] is displayed, the setting for cleaning during printing is disabled. (☞ P.3-26)

For Ink Cartridge Lamps

The condition of the ink cartridges set in the machine is confirmable with lamps located over the ink cartridges.

Ink cartridge lamps

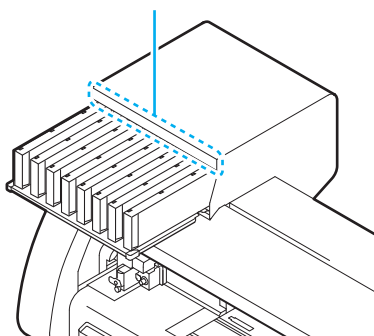

Condition of Lamp		Explanation
Upper row Red lamp	OFF	No error
	Blinking	One of the following errors occurs. <ul style="list-style-type: none"> • Almost no ink • No ink • Expiration of a term of ink validity (one month)
	ON	One of the following errors occurs. <ul style="list-style-type: none"> • No ink left • No ink cartridge inserted • Other ink errors (☞ P.7-5)
Lower row Green lamp	OFF	No error
	ON	When used with 4-color ink set, the machine supplies ink from the ink cartridge with lower ink. In this case, the cartridge being used lights in green.

Caution in Handling of Ink Cartridges



- The solvent ink contains organic solvent. If ink has stuck to your skin or clothes, immediately wash it off with detergent and water. If you have gotten ink in your eyes, immediately wash your eyes with a lot of clean water for at least 15 minutes. In doing so, also wash the back of the eyelids to rinse the ink away completely. Then, consult a doctor as soon as possible.
- Use genuine ink cartridges for this machine. This machine functions by recognizing the genuine ink cartridges. In case of trouble caused by modified ink cartridges or the like, it shall be out of the warranty even within the warranty period.
- When the ink cartridge has been moved from a cold place to a warm one, leave it at room temperature for three hours or more before using it.
- Be sure to thoroughly use up the ink in the ink cartridge within three months of it being opened. If an extended period of time has passed after opening the cartridge, printing quality will deteriorate.
- Make sure to store ink cartridges in a cool and dark place.
- Store ink cartridges in a place that is out of the reach of children.
- Request an industrial waste disposal company to dispose of an empty ink cartridge.
- Do not shake ink cartridges violently. This may result in ink leakage from the ink cartridges.
- Never refill the ink cartridge with ink. A refilled ink cartridge can cause trouble. Remember that MIMAKI assumes no responsibility for any damage caused by the use of an ink cartridge refilled with ink.
- Do not touch or stain the contacts of the ink cartridge because doing so can cause damage to the print circuit board.
- Do not disassemble the ink cartridges.



P

1

Before Use

Note on Silver and White ink of ES3 ink

Be sure to read below before using silver and white ink of ES3 ink.



- Silver and white ink of ES3 ink are usable for the firmware V and later.

● Pigments of silver ink and white ink will settle down with time.

Pigments of silver and white ink of ES3 ink have nature of settling down when they are left for a long time. If you print with ink whose pigments settle down as it is, it may cause color heterogeneity etc.

● If you have not use ink for a long time, be sure to perform “spot color maintenance” before printing.

When you print with silver ink or white ink that has set on the machine and has not been used for a long time, first perform “spot color maintenance” to prevent color heterogeneity due to settling down of pigments. (☞ P.2-40 “Perform spot color maintenance”)

● If you have left ink for a long time, the warning message is displayed when you turn on the power supply.

If you have left ink for a long time, the warning message that informs you that it is required to perform maintenance is displayed when you turn on the power supply. By referring to P.2-41 “About warning message display of performing spot color maintenance”, perform maintenance.



- Do not turn off the main power supply of this machine after you filled silver ink or white ink of ES3 ink. (If you do not use the printer, turn off the power supply with the switch on the front surface of the machine.)

Menu Mode



This machine has 4 modes. Each menu mode is described below.

Not-ready

This is the mode in which the medium has not been detected yet.

- The keys other than the **REMOTE** / **TEST PRINT/TEST CUT** key are effective.

LOCAL

LOCAL is the mode for the preparation state.

There are two LOCAL modes: [Printer mode] and [Cutting mode].

- Press the **MODE CHANGE** key to switch to the printer mode and the cutting mode.
- All the keys are effective.
- The machine can receive data from the computer. However, it does not perform printing or cutting.

LOCAL display in printer mode

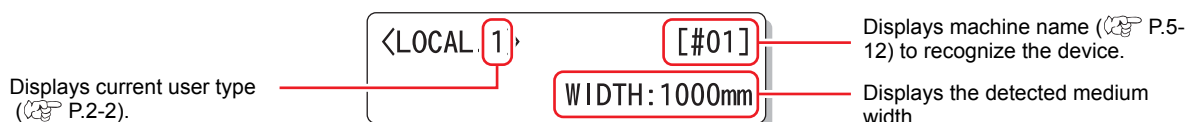

LOCAL display in cutting mode

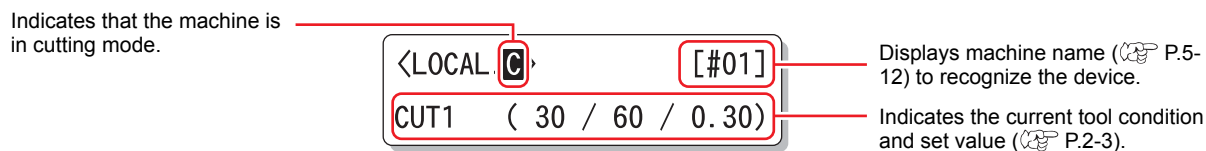

Function

To set Function mode, press the **FUNCTION** key when this machine is in Local mode. In this mode, printing conditions can be set.

REMOTE

The received data is printed or cut.

Printing or cutting can be interrupted by pressing the **REMOTE** key.

Chapter 2

Basic Operations



This chapter

describes procedures and setting methods for ink and media preparation, tool installation for cutting, and printing and cutting.

User Type for Printing	2-2	Test Printing	2-35
Settings That Can Be Registered in User Types	2-2	Perform test printing with the normal test pattern	2-36
Using the Registered User Types	2-2	Perform test printing with the test pattern for checking white ink	2-37
About Tool Conditions during Cutting	2-3	Check warning of white nozzle status (Only when using SS21 white ink)	2-38
Tool Condition Types and Their Selection Method	2-3	Head Cleaning	2-39
Registering a Tool Condition	2-4	About head cleaning	2-39
Improving Cutting Quality	2-6	Perform head cleaning depending on the test printing result	2-39
Operation Flow	2-7	Perform spot color maintenance	2-40
Turning the Power ON/OFF	2-8	Test Cutting	2-43
Turning the Power ON	2-8	Preparing for the Heaters	2-44
Turning the Power OFF	2-9	Changing the Temperature Settings for the Heaters	2-44
Installing Tools	2-10	Checking the Heater Temperature	2-45
When a Cutter Is Used	2-10	Printing Data	2-46
Exchanging Tool	2-13	Starting a Printing Operation	2-46
How to Attach a Ballpoint pen	2-14	Stopping a Printing Operation	2-47
Setting a Medium	2-15	Deleting Received Data (Data Clear)	2-47
Adjusting the Head Height	2-15	Data Cutting	2-48
Adjusting the Position of the Pinch Roller According to the State of a Medium	2-17	Starting a Cutting Operation	2-48
Roll Stopper	2-22	Stopping Cutting in a While	2-48
Maximum Print Area/Cut Area	2-23	Restarting a Cutting Operation	2-48
Notes When Using Medium Holder	2-24	Stopping a Cutting Operation (Data Clear)	2-49
Setting a Roll Medium	2-25	Removing the Cutter Unit Temporarily	2-49
Take-up Device	2-29	Cutting a Medium	2-50
Setting a Leaf Medium	2-31		
When Changing the Origin	2-33		

User Type for Printing

Register a printing condition according to each of the media that you use in a user type beforehand. When you replace one medium with another, you can set the optimum printing condition only by changing one user type to another.

Settings That Can Be Registered in User Types

For the method of registering settings in user types (1 to 4), see P.3-2.

Settings	Reference Page	Settings	Reference Page
PINCH ROLLER	P.3-5	PRE-FEED	P.3-27
MEDIA COMP.	P.3-8	COLOR PATTERN	
DROP. POS CORRECT	P.3-10	REFRESH	
HEATER	P.3-12	VACUUM	
PRINT MODE	P.3-16	FEED SPEED LEVEL	
INK LAYERS	P.3-27	PRIORITY	P.3-22
DRYING TIME	P.3-21	AUTO CLEANING	P.3-24
AUTO CUT	P.3-27	PRINT. CLEANING	P.3-26

Using the Registered User Types

- 1 Press the **MODE CHANGE** key in LOCAL to select the printing mode.

```
<LOCAL . 1>      [#01]
                WIDTH : * * * * mm
```

- 2 Press the **USER TYPE/TOOL** key.

- 3 Press **▲** **▼** to select one of the user types (1 to 4).

• You can also select one by pressing the **USER TYPE/TOOL** key.

```
USER TYPE CHANGE
TYPE (1) -> <2> : ent
```

- 4 Press the **ENTER** key.

```
<LOCAL . 2>      [#01]
                WIDTH : * * * * mm
```

Number of the selected user type

For Selecting a User Type without Using **USER TYPE/TOOL**

You can select a user type by using the **FUNCTION** key in the printer mode without pressing the **USER TYPE/TOOL** key.

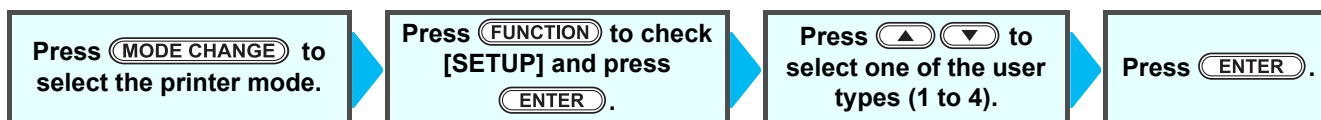

About Tool Conditions during Cutting

Register a cutting condition according to each of the media that you use in a tool condition beforehand. When you replace one medium with another, you can set the optimum cutting condition only by changing a tool condition to another.

Tool Condition Types and Their Selection Method

A tool condition consists of a cutting condition and a printing-with-a-pen condition.

You can select one tool condition by pressing the **USER TYPE/TOOL** key and determine it by pressing the **ENTER** key.

For the method of registering tool conditions, see P.2-4.



2

Basic Operations

Type	Explanation
<p>CUT1 to CUT3</p> <div style="border: 1px solid black; padding: 5px; margin-bottom: 5px;"> SPD PRS OFS [CUT1] 30 60 0.30 </div> <p style="text-align: center;">USER TYPE/TOOL</p> <div style="border: 1px solid black; padding: 5px; margin-bottom: 5px;"> SPD PRS OFS [CUT2] 20 50 0.50 </div> <p style="text-align: center;">USER TYPE/TOOL</p> <div style="border: 1px solid black; padding: 5px; margin-bottom: 5px;"> SPD PRS OFS [CUT3] 20 50 0.30 </div> <p style="text-align: center;">USER TYPE/TOOL</p> <div style="border: 1px solid black; padding: 5px; margin-bottom: 5px;"> SPD PRS OFS [PEN] 30 80 </div> <p style="text-align: center;">USER TYPE/TOOL</p>	<p>This is a tool condition when a cutter is used.</p> <div style="border: 1px solid gray; padding: 5px; margin-bottom: 10px;"> <p>This will be displayed in the following cases: When [CUT MODE] is set to "FINE" (P.4-37) When [MEDIA TYPE] is set to "HEAVY" (P.4-37) If "*" is displayed, the actual cutting speed is limited to 20cm/s.</p> </div> <div style="border: 1px solid black; padding: 5px; margin-bottom: 10px;"> SPD* PRS OFS [CUT1] 30 60 0.30 </div> <p>OFFSET Distance between the center of the cutter holder and the edge of the cutter blade (mm)</p> <p>PRESSURE Cutting pressure (g)</p> <p>SPEED Cutting speed (cm/s)</p>
<p>PEN</p> <div style="border: 1px solid black; padding: 5px;"> SPD PRS OFS [HALF] 20 40 0.30 </div> <p style="text-align: center;">USER TYPE/TOOL</p>	<p>This is a tool condition when the pen is used.</p> <div style="border: 1px solid black; padding: 5px; margin-bottom: 10px;"> SPD PRS [PEN] 30 80 </div> <p style="text-align: right;">OFFSET does not need to be set.</p>
<p>HALF</p> <div style="border: 1px solid black; padding: 5px;"> SPD PRS OFS [HALF] 20 40 0.30 </div>	<p>This is a tool condition when dotted-line cutting is performed.</p> <div style="border: 1px solid black; padding: 5px;"> SPD PRS OFS [HALF] 20 40 0.30 </div>

For Selecting a Tool Condition without Using **USER TYPE/TOOL**

You can select a tool condition by using the **FUNCTION** key in the cutting mode without pressing the **USER TYPE/TOOL** key.

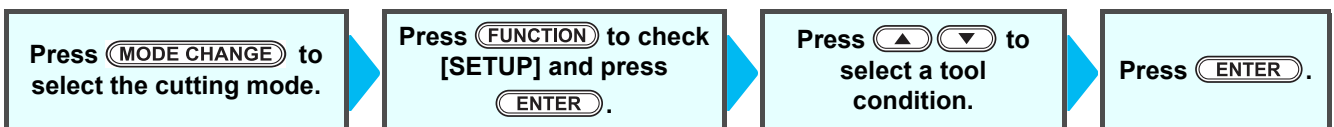

Registering a Tool Condition

- 1** Press the **MODE CHANGE** key in LOCAL to select the cutting mode.

```
<LOCAL . C>      [#01]
CUT1 ( 30 / 60 / 0.30)
```

- 2** Press the **USER TYPE/TOOL** key.

```
          SPD  PRS  OFS
[CUT1]   30   60   0.30
```

- 3** Press the **USER TYPE/TOOL** key to select a tool condition to be set.

```
          SPD  PRS  OFS
[CUT2]   20   50   0.50
```

- A tool condition consists of cutting conditions (CUT1 to CUT3), printing-with-a-pen condition (PEN), and cutting condition (HALF).

- 4** Press **▲ ▼** to set a speed.

```
          SPD  PRS  OFS
[CUT2]   20   50   0.50
```

- **Set value** : 1 to 10 cm/s (The value can be set by the unit of 1 cm/s.)
15 to 30 cm/s (The value can be set by the unit of 5 cm/s.)
- When the value is made larger, the speed becomes faster. When the value is made smaller, the speed becomes slower.
(Normally, the value is set at 20 to 30 cm/s.)

- 5** Press **▶** to select PRS (PRESSURE).

```
          SPD  PRS  OFS
[CUT2]   20   50   0.50
```

- The cursor moves to PRS.
- To return to the previous setting item, press the jog key **◀**.

- 6** Press **▲ ▼** to set a pressure value.

```
          SPD  PRS  OFS
[CUT2]   20   60   0.50
```

- **Set value** : 10 to 20 g (The value can be set by the unit of 2 g.)
20 to 100 g (The value can be set by the unit of 5 g.)
100 to 350 g (The value can be set by the unit of 10 g.)
- When selecting "PEN" for the tool condition, the maximum value is 150g.

- 7** Press **▶** to select OFS (OFFSET).

```
          SPD  PRS  OFS
[CUT2]   20   60   0.50
```

- The cursor moves to OFS.
- To return to the previous setting item, press the jog key **◀**.

- 8** Press **▲ ▼** to set an OFS value.

```
          SPD  PRS  OFS
[CUT2]   20   60   0.30
```

- **Set value** : 0.0 to 2.5 mm

- 9** Press the **ENTER** key.

```
          SPD  PRS  OFS
[CUT2]   20   60   0.30
```

- The set value is registered.



- When the printing-with-a-pen condition (PEN) has been selected in Step 3, SPEED: 30 cm/s and PRESSURE: 60 to 80g should be handled as reference values.
- It is recommended to check whether the condition set by performing test cutting is proper after registering the tool condition. (☞ P.2-43)

Important!

- When a cutting condition (CUT 1 to 3 or HALF) has been set, the cutting and throwing-away (blade edge direction alignment) operation (☞ P.4-38) is performed.
- When the PRESSURE value is set at less than 20 g in Step 7, the speed value in Step 5 needs to be set at 10 cm/s or less. Otherwise, the tool floats, and this causes letters to be blurred and cutting remainders to be generated.
- With PRESSURE (cutting pressure) being set at a large value, do not make the cutting adjustment only with the length of the blade edge drawn out.
When cutting is performed with the length of the blade edge drawn out being short and with PRESSURE being set at a large value, a strange sound may be made during cutting. In addition, the bottom surface of the cutter may rub against the sheet, causing the sheet surface to be damaged or the cutting quality to deteriorate.



2

Basic Operations

Improving Cutting Quality

Cutting quality can be improved by reducing the level of acceleration speed for cutting.

Important!

- If you set the speed reduction level, cutting speed will become slower.
(Minimum operation acceleration speed: 0.1G)

1 Press the **(MODE CHANGE)** key in LOCAL to select the cutting mode.

```
<LOCAL . C>      [#01]
CUT1 ( 30 / 60 / 0.30)
```

2 Press the **(USER TYPE/TOOL)** key.

```
SPD* PRS OFS
[CUT1] 30 60 0.30
```

3 Press the **(REMOTE)** key.

```
( 100% = 0.5G)
[CUT1] ACC. Lv. = 100%
```

4 Press **(▲)** **(▼)** to set the speed reduction level.

```
( 100% = 0.5G)
[CUT1] ACC. Lv. = 80%
```

- Setting value: 10 to 100% (10% step)
- The acceleration speed when the speed reduction level is set to 100% is displayed in the upper part of the display. Even if the speed reduction level is set to lower, the acceleration speed displayed in the upper part of the display will not be renewed.

5 Press the **(ENTER)** key.

- The set value will be registered.

• Relationships between cutting speed and acceleration speed

Item		CUT MODE		
		FINE	STANDARD	FAST
Speed [cm/s]	1 ~ 5	0.4 [G]	0.6 [G]	0.8 [G]
	6 ~ 15	0.5 [G]	0.7 [G]	0.9 [G]
	20 ~ 30	0.6 [G]	0.8 [G]	1.0 [G]

- When pen pressure (PRS) is set to 150g or higher, the acceleration speed will be 0.2G lower than the value indicated in the table shown on the left.

Operation Flow

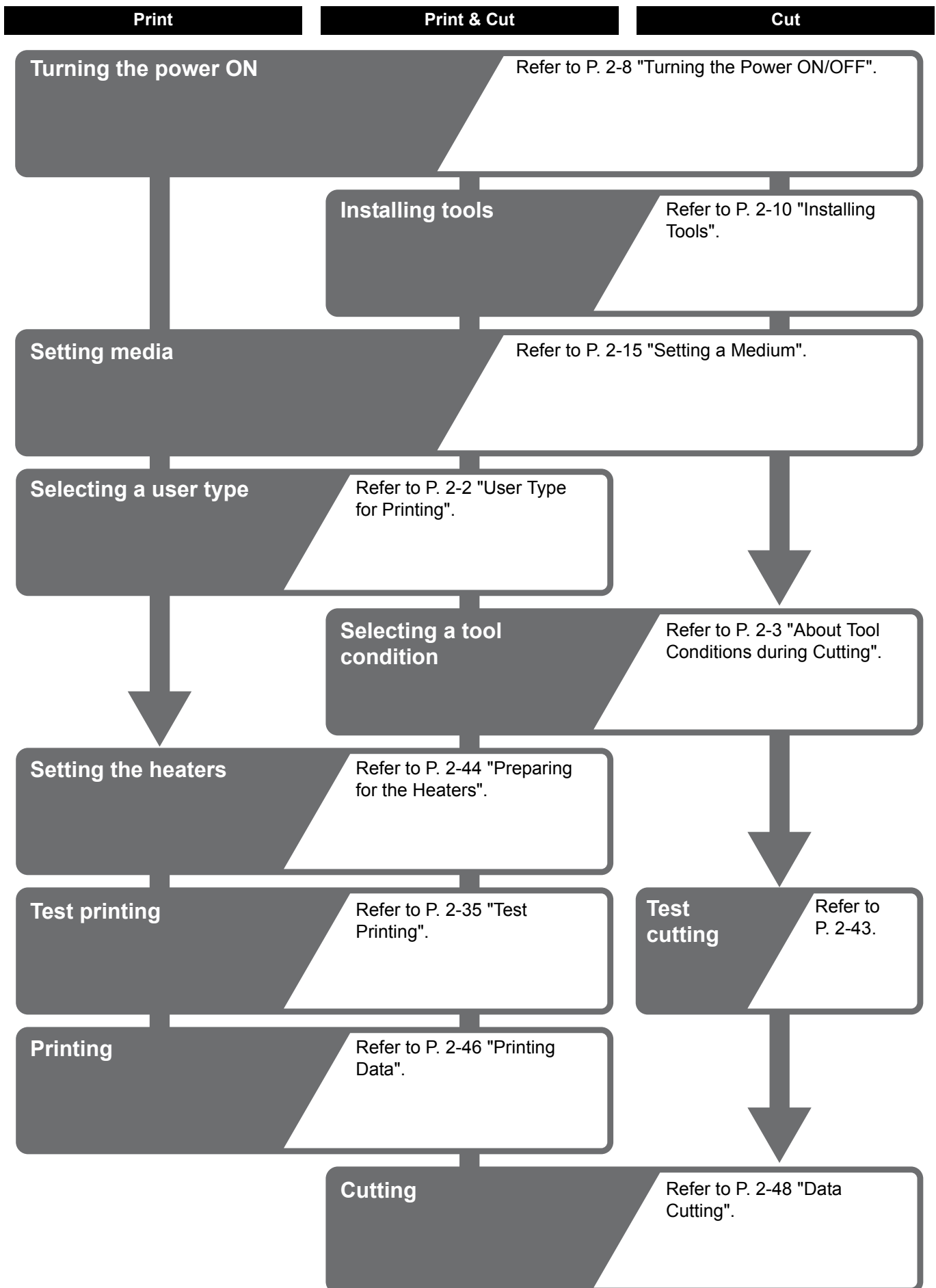

2

Basic Operations

Turning the Power ON/OFF

Turning the Power ON

This machine is provided with the following two power switches:

Main power switch : It is located on the side of this machine. Keep this switch ON all the time.

Power switch : Normally, use this switch to turn the power ON/OFF.

The power switch lights in green when the power is ON and blinks in green when it is OFF.

The nozzle clogging prevention function periodically operates even with the power switch turned OFF when the main power switch is turned ON (the power switch blinks in green).

1 Turn the main power switch ON.

- Set the main power switch located on the side of this machine to the "I" side.

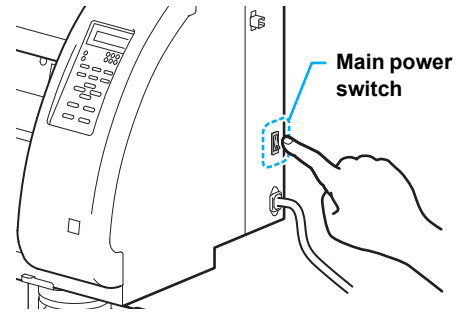

- The firmware version is displayed when the power is turned ON.
- The machine performs its initial operation.
- When the main power switch is turned on, the printer unit will go and return once on the platen.

CJV30 - 60 V * . * *

PLEASE WAIT

2 The machine enters LOCAL.

<LOCAL . 1> [#01]

3 Turn ON the power of the connected PC.

Important!

- The head nozzle may result in nozzle clogging if the main power switch is left OFF for a long time.

Turning the Power OFF

When having ended the operation of the machine, turn the power OFF by pressing the power switch located on the front side.

Check the following items when turning the power OFF.

- If the machine is receiving data from the PC or if there is any data that has not been output yet
- If the head has returned to the capping station
- If any error has occurred (☞ P.7-10 "Error Messages")

1 Turn OFF the power of the connected PC.

2 Press the power switch to turn the power OFF.

- The power switch blinks in green.
- Do not turn OFF the main power switch located on the side of the machine.
- To use this machine again, light the green lamp by pressing the power switch.
- When the adjunct unit is connected to the cutter unit, after being connected to the printer unit, the power turns OFF.

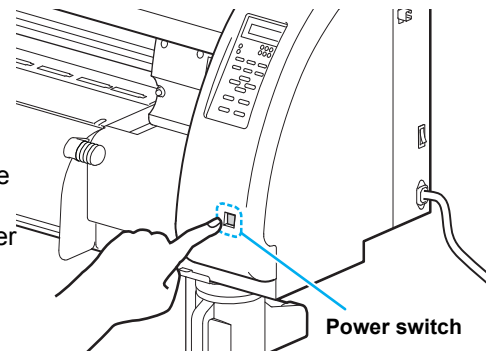

Cautions about Turning the Power OFF

● Do not turn the main power switch OFF.

When the main power switch is ON, the power periodically turns ON and the nozzle clogging prevention function (flushing function) operates.

When the main power switch has been turned OFF, the sleep functions, such as flushing, do not operate, and this may cause nozzle clogging.

● Turn the power OFF after having checked the position of the print unit.

If the power is turned OFF in a state where the print unit has not returned to the capping station, the ink head dries, which may cause nozzle clogging.

In this case, turn the power ON again and check that the print unit has returned to the capping station, and then turn the power OFF.

● Do not turn the power OFF during printing or cutting.

The head may not return to the capping station.

● After having turned the power switch OFF, turn the main power switch OFF.

When turning the main power switch off for moving the machine or for solving the error or the like, press the power switch on the front of the machine, check the display is turned off on the operation panel, and then turn the main power switch off.

Installing Tools

This machine allows you to use the following tools:

- Cutter** : This tool is selected when an image printed on a medium is cut or when letters are cut with a cutting medium.
- Pen (water-based ballpoint pen)** : This tool is used to perform “test printing” for checking how images or letters are cut actually.

When a Cutter Is Used



- **Do not touch the cutter with your fingers.**
The sharp blade edge of the cutter may cause you to get injured.
- **Do not shake the tool after having set the cutter.**
Otherwise, the blade edge may pop out, causing you to get injured.
- Store the cutter blade in a place that is out of the reach of children.
In addition, dispose of used cutter blades according to regional laws and regulations.

Mounting a Cutter Blade

1

Remove the cutter holder.

2

Loosen the locknut and remove the adjustment knob from the holder.

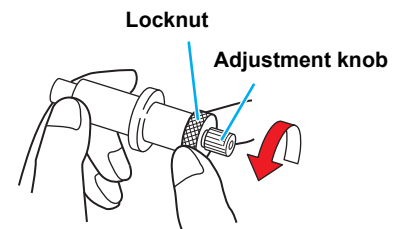

3

Insert a cutter blade in the hole of the adjustment knob.

- Pick up the cutter blade with tweezers.

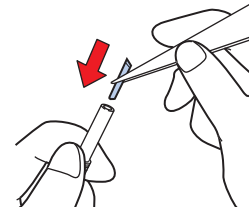

4

Tighten the locknut.

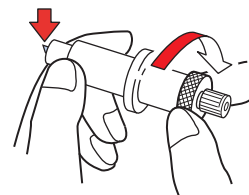

Adjusting the Blade Edge

The blade edge needs to be adjusted according to the type of cutter and medium you use. After having adjusted the blade edge, set cutting conditions and conduct test cutting to check how the cutter cuts.

Important!

- Be careful that the length of the blade edge is not too long. When the blade edge is too long, the cutter may cut the backing paper through and damage the machine.

1 Remove the cutter holder and loosen the locknut.

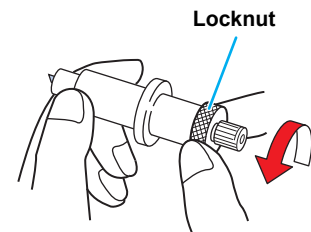

2 Rotate the adjustment knob and adjust the length of the blade edge drawn out.

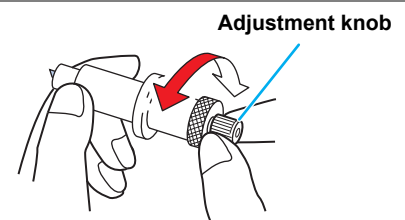

3 Tighten the locknut.

- Tighten the adjustment knob until it does not rotate any further.



Important!

- For the blade edge adjustment of cutters other than ones supplied with this machine, see the Appendix. (☞ P. 6-46)

Adjust the length of the blade edge

Depth of the blade edge that cuts in =

$$\frac{(\text{Film thickness} + \text{Backing paper thickness})}{2}$$

- However, when film thickness is less than backing paper thickness:

Reference:

Length of the blade edge drawn out = 0.3 to 0.5 mm
 (When the blade edge cuts badly, replace the blade with another.)

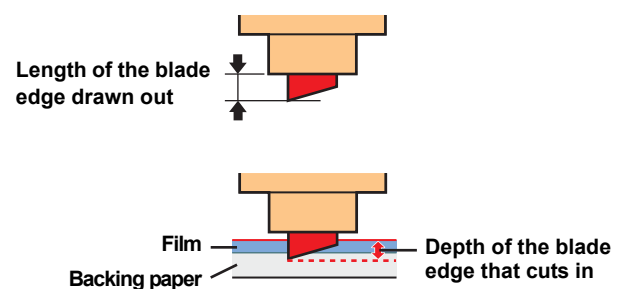

Important!

- Adjust the pressure so that the backing paper has a little cutting streak.
- When the backing paper thickness is less than the film thickness and, therefore, accurate cutting quality cannot be obtained, changing the length of the blade edge may produce a good result.



2

Basic Operations

Installing the Cutter Holder

Important!

- Insert the cutter holder firmly so that there is no space under the holder.

1

Insert the cutter holder into the tool holder.

- Press the cutter brim on the tool holder.

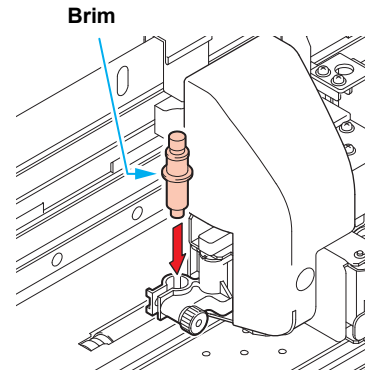

2

Fix the cutter holder.

- Rotate the knob of the tool holder clockwise and fix the tool firmly.

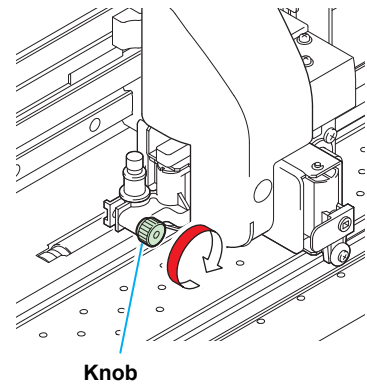

Important!

- Fix the cutter holder firmly. When the cutter holder has been fixed loosely, no accurate cutting (printing-with-a-pen) quality can be expected.

Exchanging Tool

1

Press the **MODE CHANGE** key in LOCAL to select cutting mode.

```
<LOCAL .C>      [#01]
CUT1 ( 30 / 60 / 0.30)
```

2

Press the **FUNCTION** key.

```
FUNCTION
SETUP          <ENT> C
```

3

Press **▼** **▲** to select [MAINTENANCE].

```
FUNCTION
MAINTENANCE   <ENT> C
```

4

Press the **ENTER** key.

```
MAINTENANCE
MARK SENSOR   <ent>
```

5

Press **▼** **▲** to select [TOOL REPLACE].

```
MAINTENANCE
TOOL REPLACE  <ent>
```

6

Press the **ENTER** key.

```
TOOL REPLACE
ACTION        :ent
```

7

Press the **ENTER** key.

- The cutter unit moves to the left end of the machine.
- Now the cutter unit can be moved manually. Move the cutter unit to the position where you can assure easy access, and then replace the blade edge.

Important!

- Do not touch until the cutter unit stops.

8

See P.2-12 "Installing the Cutter Holder" to replace the cutter holder.

- When exchanging the cutter blade, refer to P.2-10 "Mounting a Cutter Blade".
- Adjust the length of the blade edge as required. (☞ P. 2-11)

9

When replacement is finished, press the **ENTER** key.



2

Basic Operations

How to Attach a Ballpoint pen

Important!

- When you use a ballpoint pen sold on the market, use one with a diameter of 8 to 9 mm. Image quality may change, depending on the pens to be used. (Recommended ballpoint pen: K105-A and K105-GA (product No.) manufactured by Pentel Co., Ltd.)
- Ballpoint pens shown right may lean over and make contact with the cover when they are held by the pen adaptor. (Pen whose pen holder's diameter changes, depending on its parts/Pen that has projections or steps on its pen holder)



Pen whose pen holder diameter changes, depending on its parts



Pen that has projections or steps on its pen holder

1 Put the cap on the pen adaptor.

- The cap is used to adjust the height of the pen.

2 Insert a pen into the pen adaptor.

- Insert the pen until the point of the pen touches the cap.

3 Fix the point of the pen.

- Tighten the fixing screw clockwise.
- Be careful not to turn the fixing screw of the pen adaptor too tight. Otherwise, the ballpoint pen may break.

4 Remove the cap.

5 Insert the pen adaptor to which the pen has been attached into the tool holder.

- Press the brim of the pen adaptor on the tool holder.
- Set the pen adaptor so that the fixing screw does not touch anything.

6 Fix the tool.

- Turn the knob of the tool holder clockwise and fix the tool firmly.

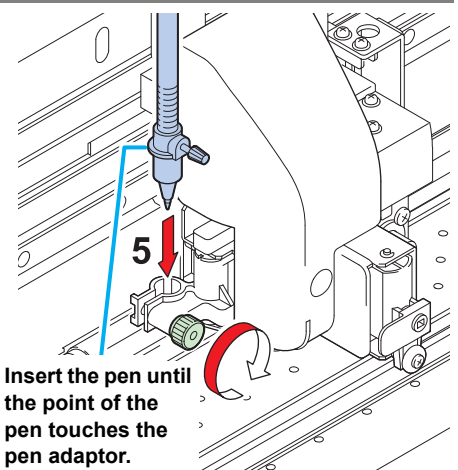
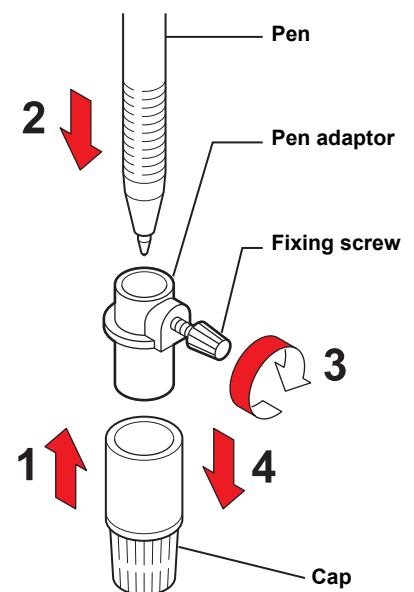

Setting a Medium

This machine can be used with a roll medium and leaf medium.
For usable media, refer to P.1-11 "Usable Sizes of Media".

Adjusting the Head Height

Adjust the head height according to the thickness of the medium you use.

Important!

- Adjust the head height prior to setting the medium. If the head height is adjusted after the medium is set, this may cause a medium jamming, deterioration of the print quality or head damage.
- If the drawing quality is set to "Bi-D" (☞ P.3-18), perform "Dot position correction" of the maintenance function after the head height is adjusted. (☞ P.3-10).

1

Move the carriage to the platen.

- When the device is turned ON:
Execute [ST.MAINTENANCE - CARRIAGE OUT] of the Maintenance functions.
(☞ P.6-6 Steps 1 and 2)
- When the device is turned OFF:
Move the carriage by hand.

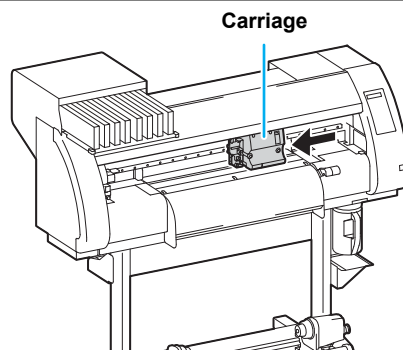

2

Loosen the two screws located at the front.

- Loosen the screws, rotating each by one turn of a screwdriver.

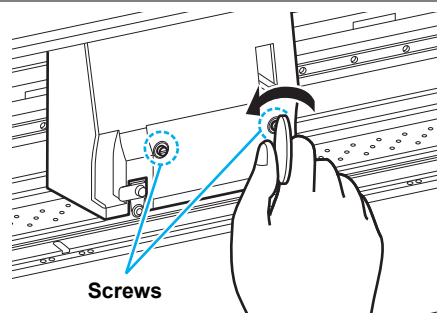

3

Adjust the height-adjusting lever according to the medium.

- Adjust the position of the lever, referring to "For the Adjusting Lever and the Range".
- Set the height-adjusting lever to the highest stage or the lowest stage. Setting it to the intermediate height, a printing fault can result.

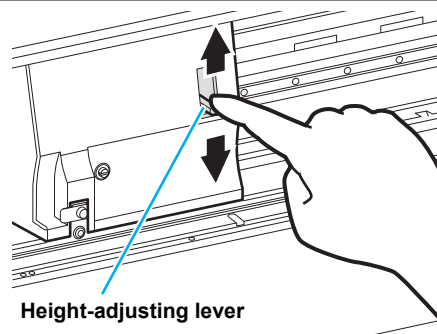

4

While keeping the height-adjusting lever held at the aforementioned position, tighten the two screws.

- Be sure to fasten the screws, pressing the height-adjusting lever, otherwise the head cannot be secured at the correct position.
- Fasten the screws securely.

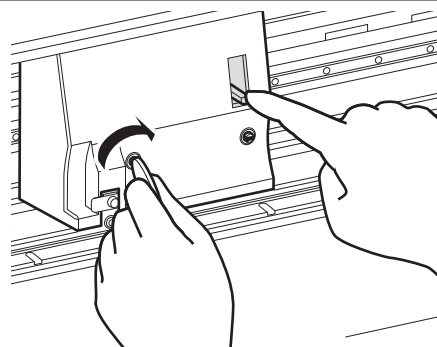

P

2

Basic Operations

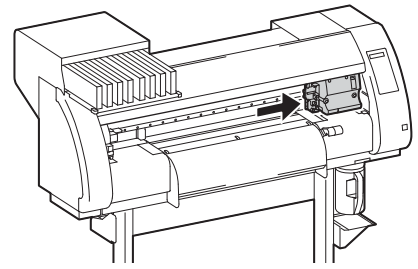
5**Return the carriage to the station position.****P**

For the Adjusting Lever and the Range

Height-adjusting lever	Head height	Switching area
Thin	2 mm (The set position before shipping)	Switch by user
Thick	3 mm	



- Set the lever to "Thick" when a thicker medium such as tarpaulin or FF is used.
- Set the lever to "Thick" when the medium is prone to gather dust in the head or is often stained with ink traces.



- When using a medium of 1 mm thickness or below and SS21 ink, be sure to set the head height to "Thin".
If used with the head height "Thick", the head gap (between the medium and the height of head nozzle surface) can be too large and ink drops may be splashed, and so the image quality cannot be assured.

Adjusting the Position of the Pinch Roller According to the State of a Medium

Adjust the position of the pinch roller according to the width of the medium to be set. This machine feeds the medium with a pinch roller and grid roller for printing or cutting. The pinch roller should be above the grid roller.

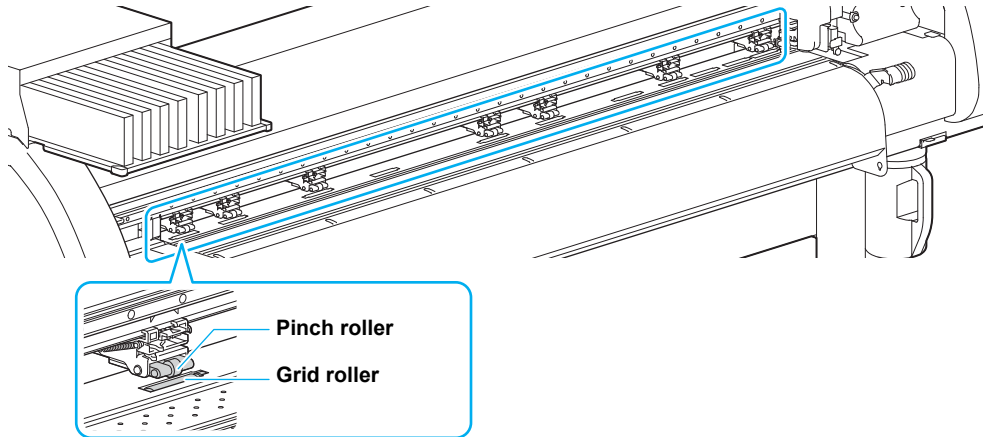

How to Adjust the Pinch Roller

Move the pinch roller unit to adjust the position of the pinch roller. Use the pinch roller guide mark for positioning.

To adjust the pinch roller from the front side:

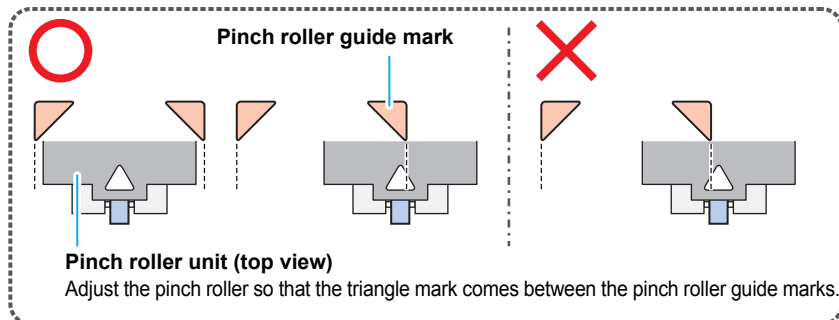

To adjust the pinch roller from the rear side:

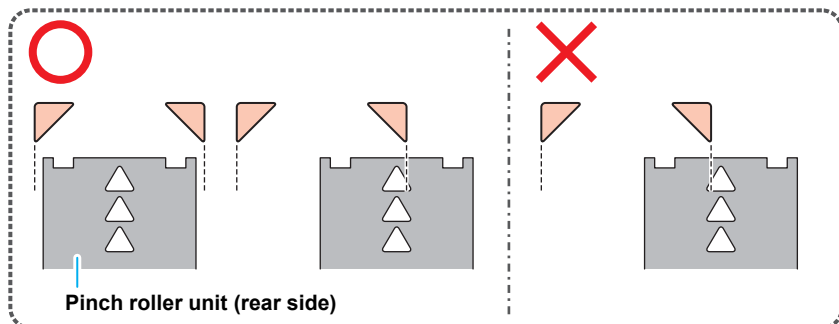

Medium Size and the Grid Roller (CJV30-160)

The grid roller positions are determined by the size of the medium.

Important!

- To feed the medium smoothly, select the grid roller positions so that the medium can be held at equally spaced intervals.
- When the grid rollers to be used are determined, adjust the pinch roller unit referring to "How to Adjust the Pinch Roller" of P. 2-17.
- You can use any number of pinch roller units from 2 to 7.
- Adjust the pinch roller of both ends so that they are within the range of 10cm from medium left end and 2cm from medium right end. If adjusting them to the further position, it will remain uncut when cutting the medium.

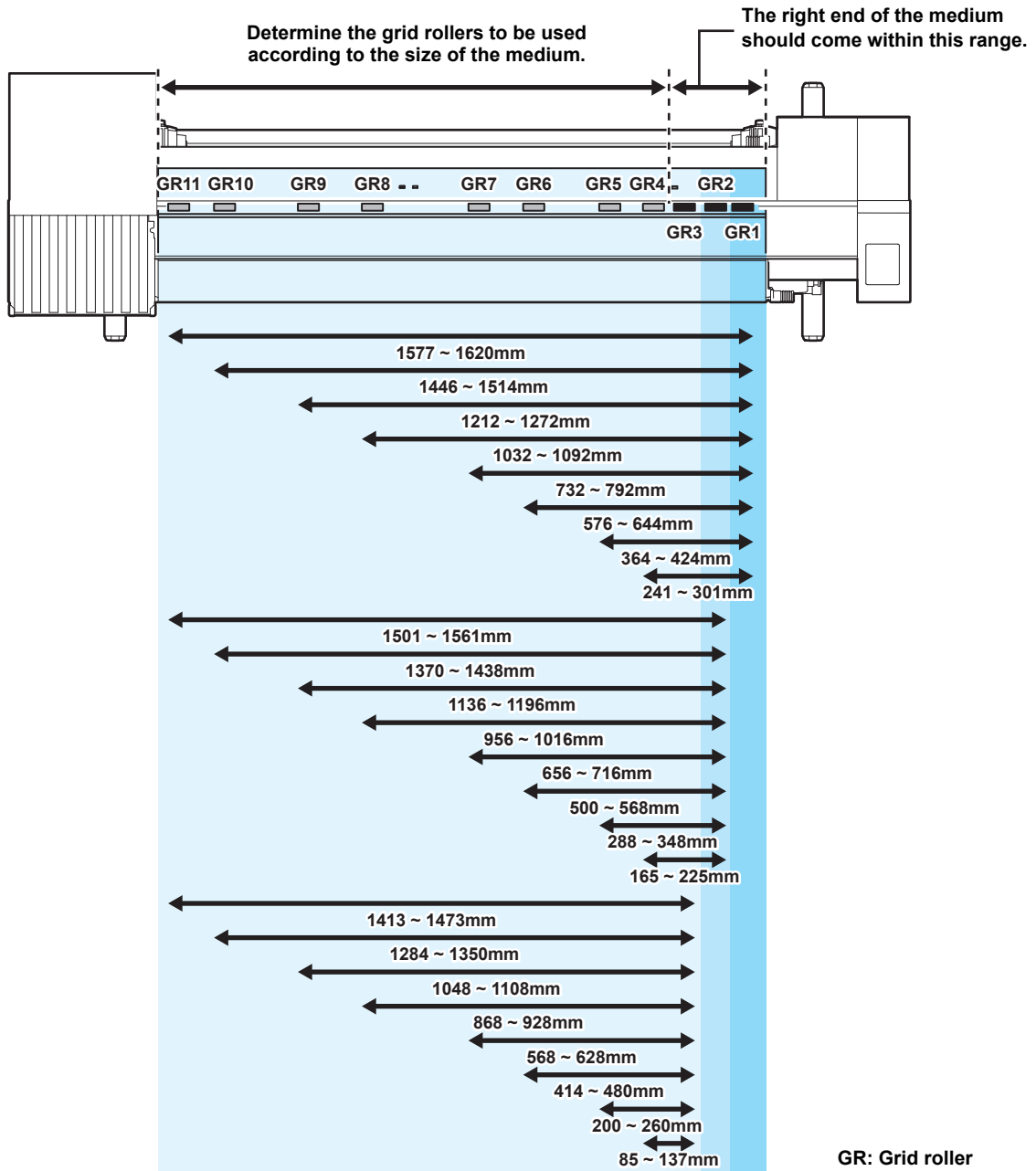

Medium Size and the Grid Roller (CJV30-130)

The grid roller positions are determined by the size of the medium.

Important!

- To feed the medium smoothly, select the grid roller positions so that the medium can be held at equally spaced intervals.
- When the grid rollers to be used are determined, adjust the pinch roller unit referring to "How to Adjust the Pinch Roller" of P. 2-17.
- You can use any number of pinch roller units from 2 to 6.
- Adjust the pinch roller of both ends so that they are within the range of 10cm from medium left end and 2cm from medium right end. If adjusting them to the further position, it will remain uncut when cutting the medium.

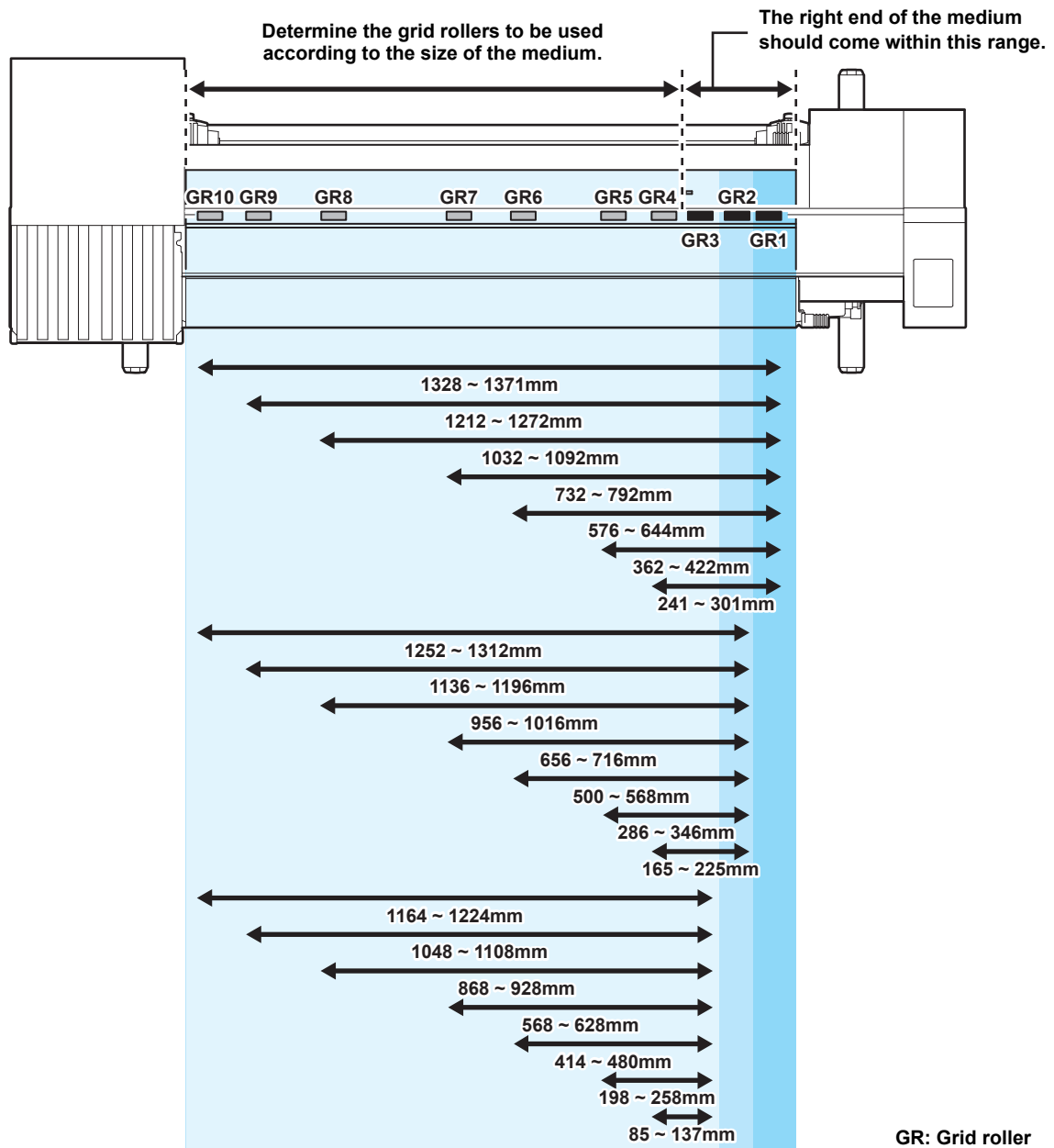

Medium Size and the Grid Roller (CJV30-100)

The grid roller positions are determined by the size of the medium.

Important!

- To feed the medium smoothly, select the grid roller positions so that the medium can be held at equally spaced intervals.
- When the grid rollers to be used are determined, adjust the pinch roller unit referring to "How to Adjust the Pinch Roller" of P. 2-17.
- You can use any number of pinch roller units from 2 to 4.
- Adjust the pinch roller of both ends so that they are within the range of 10cm from medium left end and 2cm from medium right end. If adjusting them to the further position, it will remain uncut when cutting the medium.

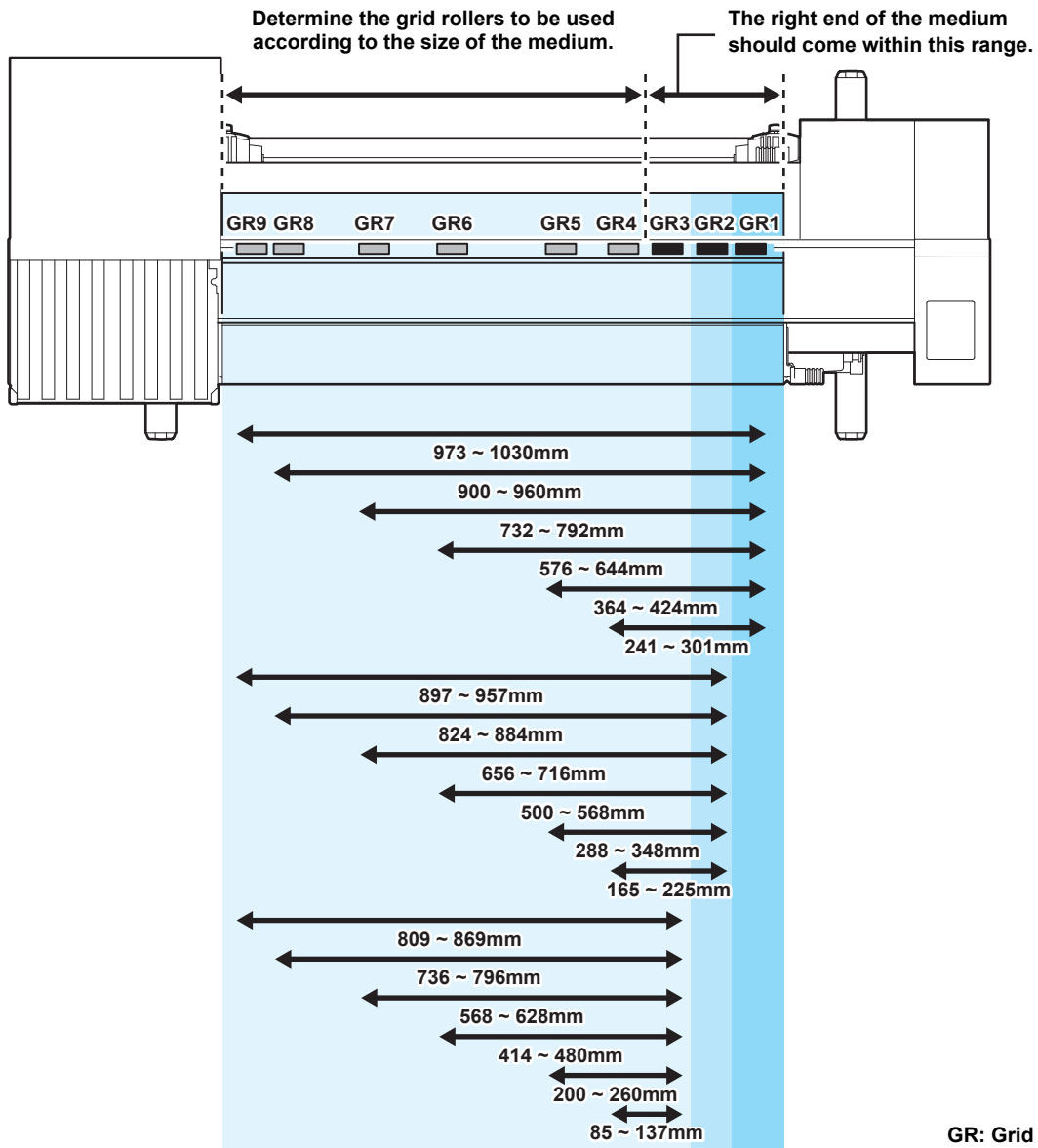

Medium Size and the Grid Roller (CJV30-60)

The grid roller positions are determined by the size of the medium.

Important!

- To feed the medium smoothly, select the grid roller positions so that the medium can be held at equally spaced intervals.
- When the grid rollers to be used are determined, adjust the pinch roller unit referring to "How to Adjust the Pinch Roller" of P. 2-17.
- Be sure to prepare two or more pinch roller units.
- Adjust the pinch roller of both ends so that they are within the range of 10cm from medium left end and 2cm from medium right end. If adjusting them to the further position, it will remain uncut when cutting the medium.

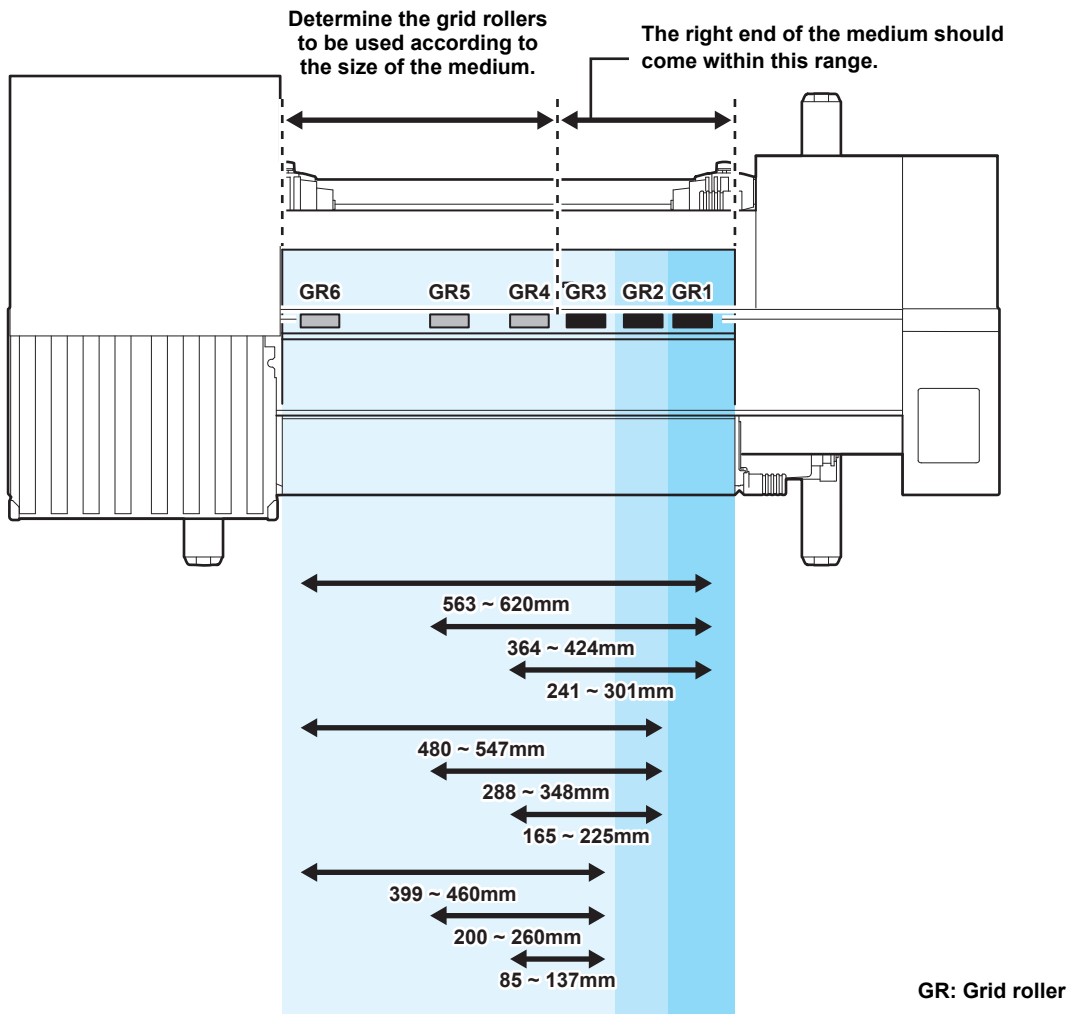

P

C

2

Basic Operations

Roll Stopper

When the medium is set and a certain amount is pulled out, the roll stopper function is activated to stop the roll holder temporarily. This function is provided to prevent unnecessary pull-out of the medium.



- The roll stopper works with the clamp lever. Do not push the clamp lever down while the roll stopper is caught between the roll stopper arm and the this machine. The roll stopper arm might be broken and the roll stopper function might be disabled.

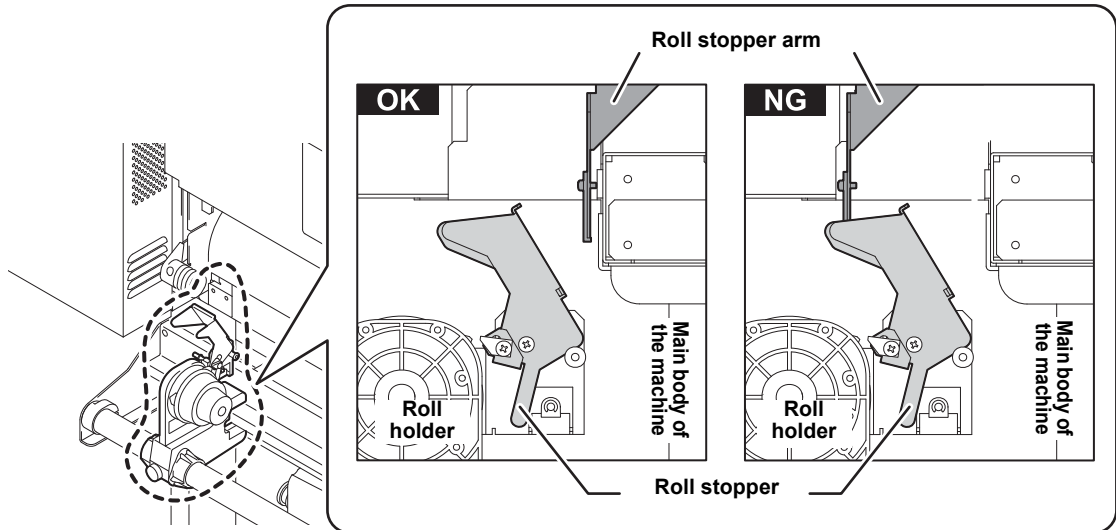

Locking the roll stopper manually

Depending on the roll holder set location, the roll stopper arm may not be able to lock the roll stopper. In this case, follow the steps below to lock the roll stopper.

- 1** Pull the roll stopper in the direction shown right.

- 2** Press the lock pin to hold the roll stopper.

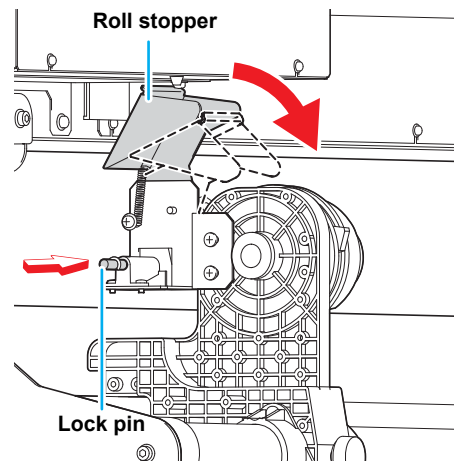

Maximum Print Area/Cut Area

The maximum printed area/cut area varies, depending on the position of the pinch roller (☞ P.2-18 to P.2-21) and the origin position (☞ P.2-33). The white area shown in the following figure represents the maximum print/cut area.

The area other than that is the dead space that cannot be printed/cut.

	CJV30-60	CJV30-100	CJV30-130	CJV30-160
Maximum printing/cut width	610 mm	1,020 mm	1,361 mm	1,610 mm



2

Basic Operations

- Expand the maximum printed/cut area with the Expand function of the Common settings

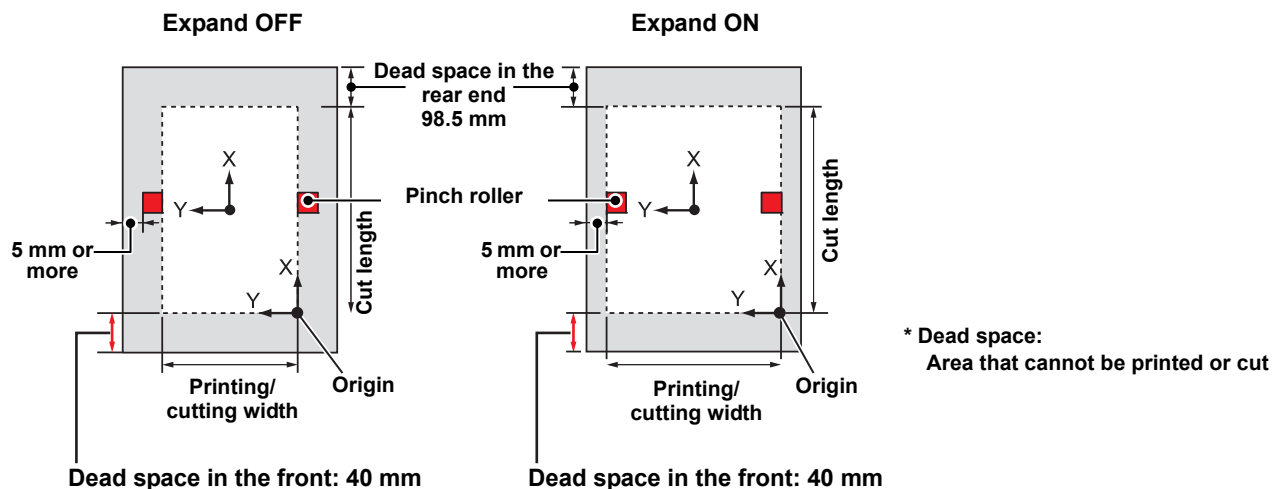

- The recommended dead space in the front end is 40 mm or more. (Turn the expand function "OFF" ☞ P.5-6) If the dead space in the front end is too small, the media may become loose. This affects print or cut quality.

Notes While Expand Function Is ON



- While the expand function is ON, keep the end of the medium holder from coming in contact with the pinch holder. It will cause the stain on the medium when printing.
- Make a clearance of 1 mm or above between the end of the medium holder and the pinch holder.

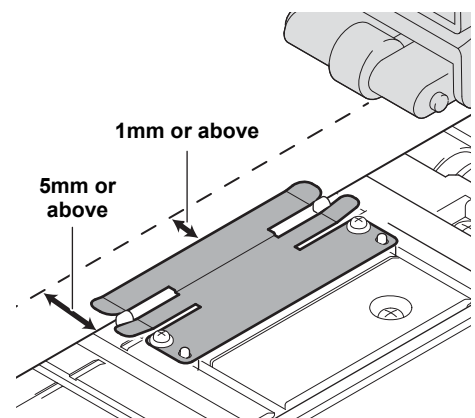

Notes When Using Medium Holder

Setting Position of the Medium

Set the medium so that the right end of the medium will be inside the area shown below.

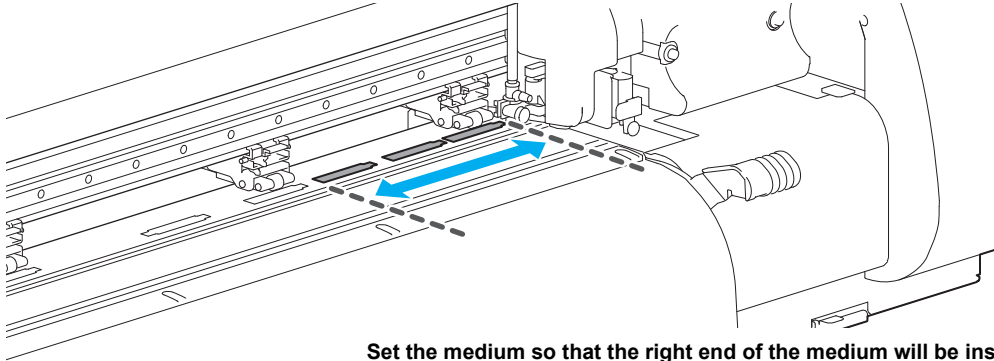

Set the medium so that the right end of the medium will be inside the area shown by an arrow. (up to the 3rd grid roller from the right end in front of the main body)

The End of the Medium Should Not Exceed the Slit Line on the Platen



- If the medium is set with its end exceeding the slit line on the platen, the medium may be lifted when it is fed obliquely. This may cause damage to the head.

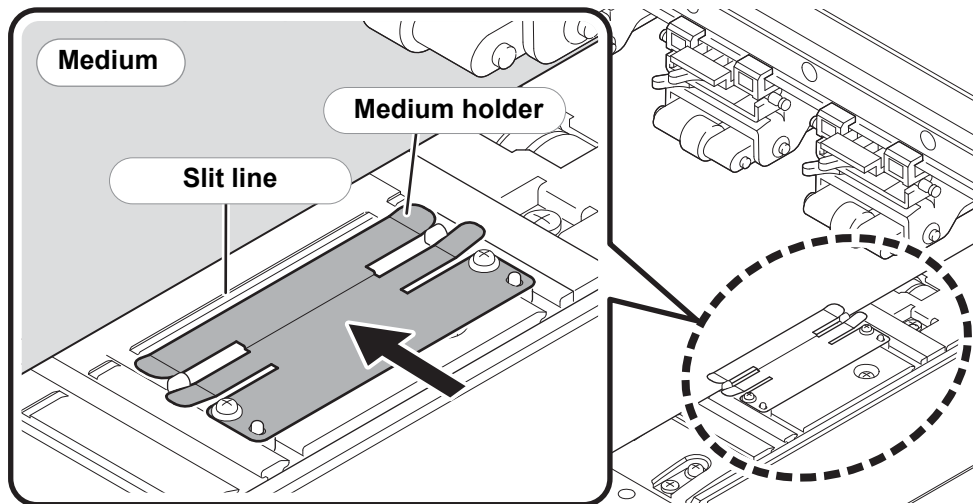

Setting a Roll Medium

Set a roll medium to the roll media hanger located on the back of this machine.



- Take care not to drop the medium on your foot when setting the medium. It may cause an injury due to the medium.



- If the cutter unit is on the platen, press the **HEATER/CUTTER** key to evacuate the cutter unit. (☞ P.2-49)



1 Move the roll holder located in the back of the device in the direction of the middle of the device.

- Loosen the roll holder fixing screw and then move it.

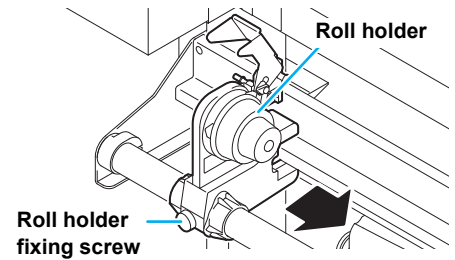

2 Check that the clamp lever is lowered.

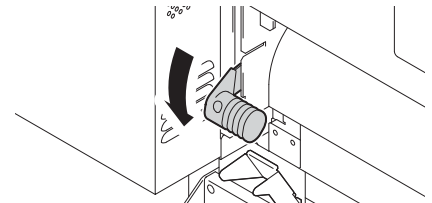

3 Move the roll holder to the roll setting position.

- Check the medium size and the position to set the medium, referring to the section applicable to your machine (☞ P.2-18 to P.2-21).

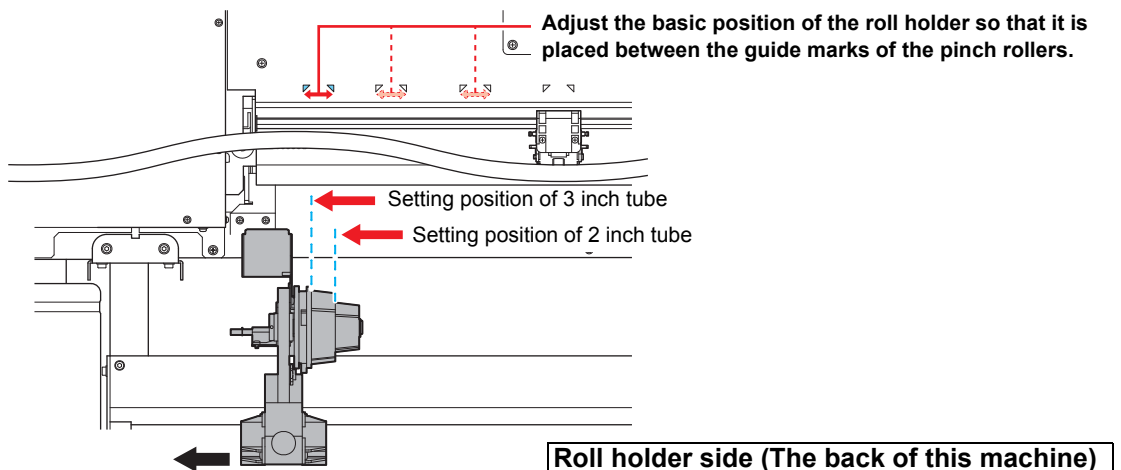

- Check that the roll stopper is not caught between the roll stopper arm and this machine.
- If the roll stopper arm and the roll stopper are interlocked and they don't move, enable the roll stopper function manually. (☞ P.2-22)

2

Basic Operations

4**Tighten the roll holder fixing screw.**

- Check the Steps 2 to 3 again.

5**Set the left end of the core of the roll medium on the left roll holder.**

- Push the roll medium onto the roll holder until the roll core is all the way seated.

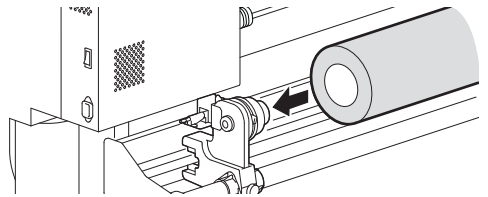
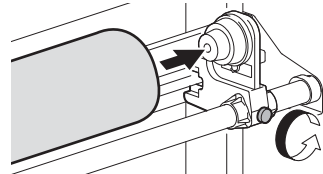
**6****Loosen the screw of the right side roll holder, then insert the holder into the core of the roll medium.****7****Raise the clamp lever in the rear side of this machine.**

- When the setting of the pinch roller pressure is "OFF" (☞ P.3-6, P.4-3), raising the clamp lever will change the setting from "OFF" to "LOW". (Because the medium will be surely held when changing the medium size.)

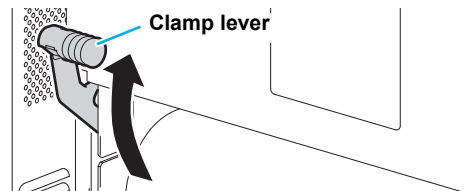
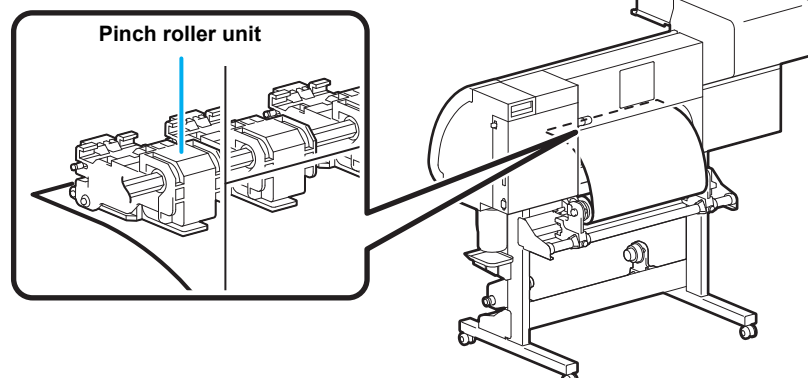
**8****Insert the roll medium in this machine.**

- The roll medium can be smoothly inserted by slanting the medium.

(1) Pull the medium out of the roll to the head of the platen.

(2) Insert the medium between the platen and the pinch roller units.

- Pull the medium out of the roll so that the medium can be grasped from the front of the machine.

(3) Push down the clamp lever from the back of this machine.

- The medium is held.



- Set the pinch roller units so that the medium can be held at equally spaced intervals. If the pinch rollers cannot be set at equally spaced intervals, start over from Step 3.
- Ensure there is a dead space of 5 mm or above at each end of the medium.

9 Pull out the roll medium out.

- (1) Raise the clamp lever from the front of this machine.
- (2) Pull out the roll medium gently and then stop pulling when locked lightly.

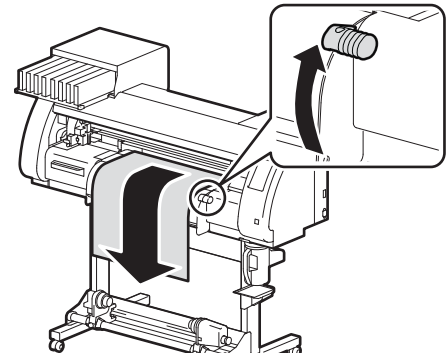

10 Make the roll medium even, then lower the clamp lever.

- Pulling several positions of the medium lightly, lower the clamp lever after confirming that the amount of the roll medium pulled out is almost even.

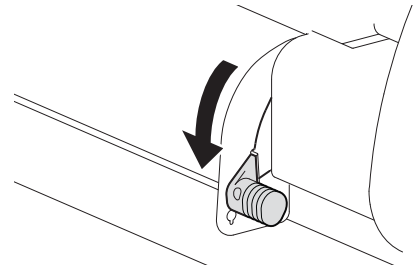

11 For printing, clip lightly the medium with the medium holder.

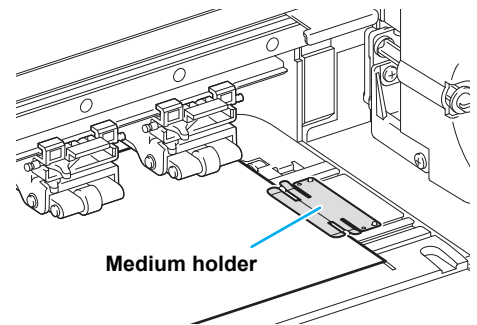

- When using a thick medium, remove the medium holder from the medium before printing.
- When setting the medium holder, refer to P.2-24.
- You do not need to use the medium holder for cutting.

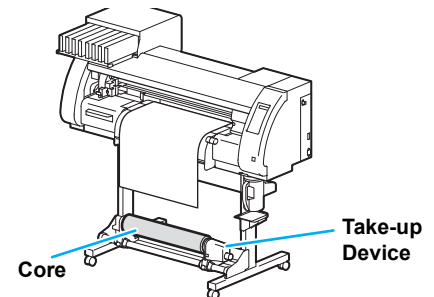

12 Prepare the take-up device.

- Set an empty core of the roll medium on the take-up device.



13 Press   to set the number of the pinch roller at the left end of the medium.

- Set the number of the pinch roller at the left end of the set medium.
- Press  to skip the pinch roller pressure setting from Step 14 to Step 17.

** PINCH ROLLER **
PINCH ROLLER: No. **7** t o 1

14 Press the **ENTER** key.

Current mode and pinch roller pressure is indicated with [>].

>PRINT	[MMMMMM]
CUT	[H____H]

15 Check the current pinch roller pressure.

- To change the set pinch roller pressure temporarily, follow the steps below.
- (1) Press **◀▶** to select a pinch roller to set.
- (2) Press **▲▼** to set the pressure.

16 Press the **ENTER** key.

17 Press the **◀** key to select "ROLL".

- Detects the medium width.
- When "Remaining amount of a medium to display" of the maintenance function is "ON" (☞ P.6-34), the screen for entering medium remaining amount is displayed after detecting the medium width. (☞ P.2-29)

MEDIA SELECT	
ROLL <	> LEAF

18 Secure the medium on the take-up device. (☞ P.2-29)

- (1) Feed the medium up to the core of the roll medium of the take-up device by pressing the **▼** key.
- (2) Fix the middle of the medium with adhesive tape.
- (3) In the same manner, fix the left side and right side of the medium.
 - Make sure that there is no slack or wrinkle on the medium by pulling it to the right and left evenly, and then fix it with a piece of tape.

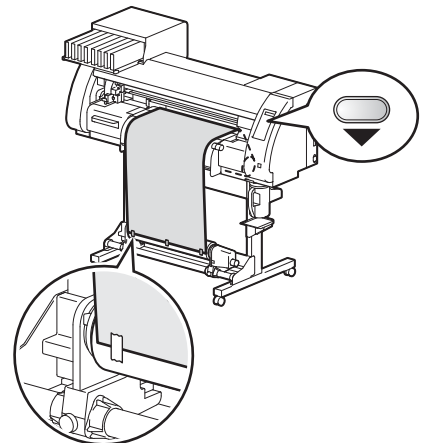

- Once a printing condition or a cutting condition appropriate to the media is registered when setting the type and the tool condition, setting the pinch roller on Step 13 to 15 is not needed.
- When performing the settings for the first time, the values displayed in step 14 display the values configured by the type registration and tool conditions.
- The value set in Steps 13 to 16 will be held until the power is tuned OFF or until the function "Setting for the pinch rollers" (☞ P.3-5 and P.4-2) is changed.
- The value set here will be displayed next time when the medium is set.
- The setting for the pinch roller can be canceled when the medium is set, using the common settings "Setting for the pinch rollers" (☞ P.5-3).

Entering the Medium Remaining Amount

When "Remaining amount of a medium to display" of the maintenance function is "ON" (☞ P.6-34), the screen for entering medium remaining amount is displayed after detecting the medium width.



- The medium remaining amount can be entered only when a medium or a roll is detected in the printer mode.

1

Display the screen for entering medium remaining amount.

```
Input of MediaLength
MEDIA LENGTH = ***.*m
```

2

Press keys to enter the medium remaining amount.

```
Input of MediaLength
MEDIA LENGTH = 50.0m
```

3

Press the key.

2

Basic Operations

Take-up Device

Adjusting the switch

The take-up direction of the medium is selectable by using the switch of the take-up device.

Lever in top position (REVERSE) :

The take-up device winds the medium with the printed side facing in.

Lever in middle position (OFF) :

The take-up device does not wind the medium.

Lever in bottom position (FORWARD) :

The take-up device winds the medium with the printed side facing out.

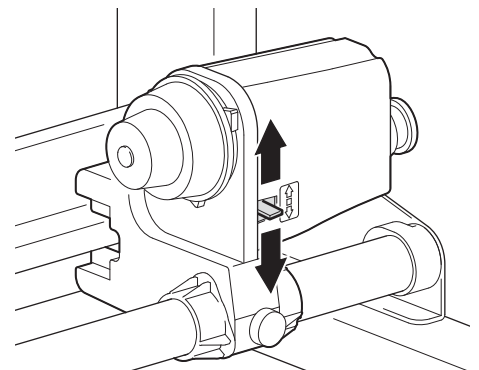

Setting the Torque Limiter

The take-up device is provided with a torque limiter. The take-up torque can be adjusted with the torque limiter. (The torque limiter is set at the maximum value when shipped from the factory.)

In the following cases, make the adjustment:

- (1) when the tension is too strong in using thin medium
- (2) when performing combined operation of print & cut

- A clockwise turn : Increases torque (a heavy and thicker medium such as tarpaulin or the like)
- A counterclockwise turn : Decreases torque (for light medium)

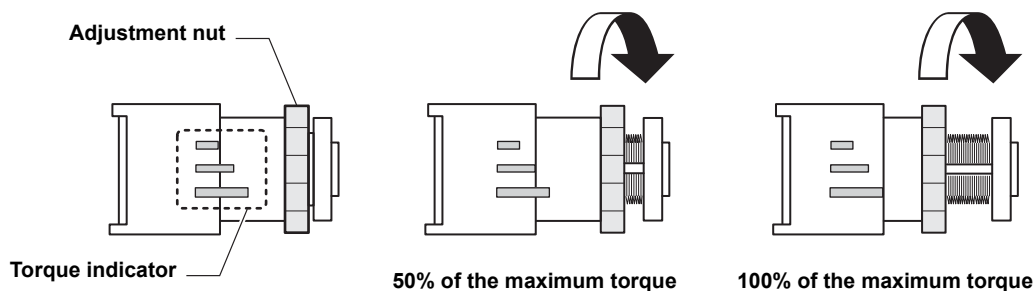

Important!

- **When the torque limiter is adjusted too weak:**
The medium cannot be taken up firmly.
- **When the torque limiter is adjusted too strong:**
Slack may occur depending on the medium and have an influence on the image quality. In addition, when performing combined operation of print & cut and when making the medium return to the cutting start position, it may not return to the origin of the resister mark after printing is completed.

When Not Using Taking-up Device



- When performing printing or cutting of 700 mm or more without using the taking-up device, evacuate the taking-up device to right and left. The quality of the print and cut may become low because of the impact when the front end of the medium touches the taking-up device. (Same as when fixing the optional dry evacuation unit)

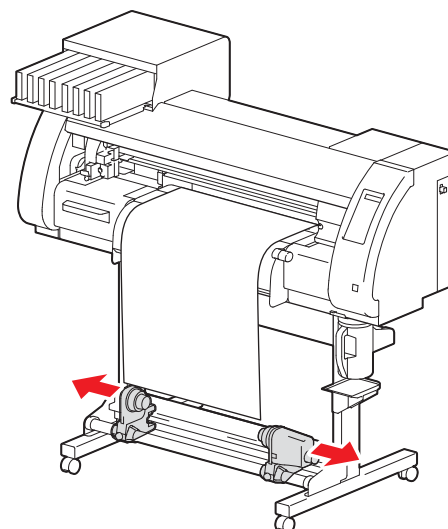

Setting a Leaf Medium

Unlike a roll medium, a leaf medium does not need to be retained with the roll holders.



- If the cutter unit is on the platen, press the **HEATER/CUTTER** key to evacuate the cutter unit. (P.2-49)

1

Raise the clamp lever.

- When the setting of the pinch roller pressure is “OFF” (P.3-6, P.4-3), raising the clamp lever will change the setting from “OFF” to “LOW”. (Because the medium will be surely held when changing the medium size.)

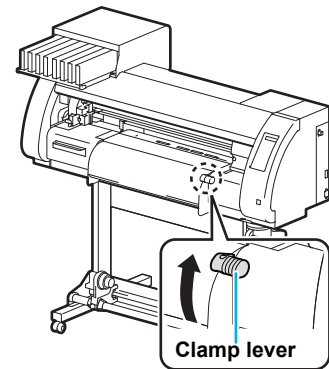

2

Insert the leaf medium between the platen and the pinch rollers.

- Check the medium size and the position to set the medium, referring to the section applicable to your machine (P.2-18 to P.2-21).

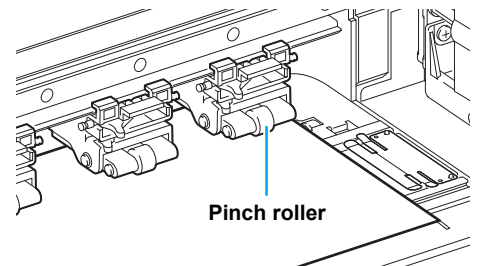

3

For printing, clip lightly the medium with the medium holder.

- When using a thick medium, remove the medium holder from the medium before printing.
- When setting the medium holder, refer to P.2-24.
- You do not need to use the medium holder for cutting.

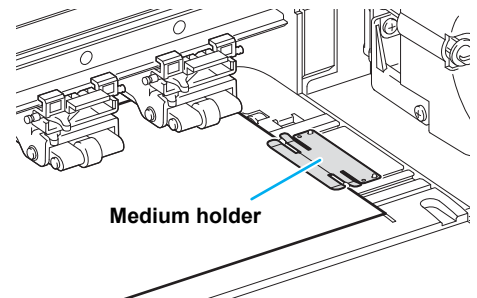



- Set the pinch roller so that the medium is held at equally spaced intervals. If the pinch rollers cannot be set at equally spaced intervals, start over from Step 2.
- Ensure there is a dead space of 5 mm or above at each end of the medium.

4

Push down the clamp lever.

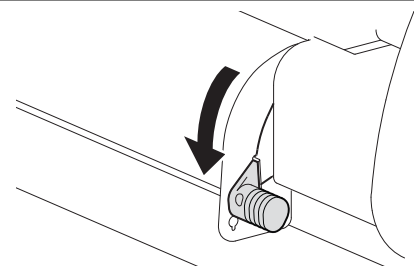
- Set the medium straight.



5 Press   to set the number of the pinch roller at the left end of the medium.

** PINCH ROLLER **
PINCH ROLLER:No. **7** to 1





- Set the number of the pinch roller at the left end of the set medium.
- Press  to skip the pinch roller pressure setting from Step 6 to Step 9.

6 Press the  key.

Current mode and pinch roller pressure is indicated with [>].

 >PRINT [MMMMMMM]
CUT [H_____H]

7 Check the current pinch roller pressure.

- To change the set pinch roller pressure temporarily, follow the steps below.
(1) Press   to select a pinch roller to set.
(2) Press   to set the pressure.

8 Press the  key.

9 Press the  key to select "LEAF".



MEDIA SELECT
ROLL < > LEAF

10 The medium detection is started.

DETECTING MEDIA NOW
PLEASE WAIT

- (1) The medium width is detected.
- (2) The medium is fed then the rear end of the medium is detected.
- (3) It returns to LOCAL when the detection is completed.



- Once a printing condition or a cutting condition appropriate to the media is registered when setting the type and the tool condition, setting the pinch roller on Step 5 to 7 is not needed.
- When performing the settings for the first time, the values displayed in step 6 display the values configured by the type registration and tool conditions.
- The value set in Steps 5 to 8 will be held until the power is turned OFF or until the function "Setting for the pinch rollers" ( P.3-5 and P.4-2) is changed.
- The value set here will be displayed next time when the medium is set.
- The setting for the pinch roller can be canceled when the medium is set, using the common settings "Setting for the pinch rollers" ( P.5-3).

When Changing the Origin

The position of the print origin can be changed.

Move the print origin to the intended position and determine the origin position.



- When changing the origin position in the printer unit, use the [ORIGIN] seal put on the printer unit as a reference.
- When changing the origin position in the cutter unit, use the tool holder (pen point) of the cutter unit as a reference.

Important!

- To print with the cross direction (Y direction) aligned with the previous printing position while printing & cutting the data with the register mark, do not change the origin.
- After cutting the data with the register mark (☞ P.4-5), the position in the cross direction (Y direction) of the tool holder (pen point) is on the corner line of the TP1 register mark. If the origin is set with this position, the succeeding printing starts from this position, and may be misaligned with the previous printing.

1





In LOCAL, press the     keys.

- LOCAL changes to the origin setting mode.

```
ORIGIN SET UP
0.0  ----
```

2

Pressing the     to set origin to the intended position.

- Select the carriage and medium, moving the point with the    .

```
ORIGIN SET UP
0.0  0.0
Origin (Length)  Origin (Width)
```

3

After determining the origin, press the  key.

- The origin is changed.

```
ORIGIN SET UP
** ORIGIN **
```

P

C

2

Basic Operations

Reference for Setting Position of the Origin

The print origin in the depth direction (X') is positioned at about 40 mm rearward from the cutting line.

The scanning direction (Y') is positioned at the left end of the first pinch roller (the right end pinch roller seen from the front of the main body).

The value in the scanning direction (Y') can be changed using "Margin" (P.5-8) in Function mode. This can be changed by using the jog key.

Important!

- Put a 5mm or more space between the right edge of the first pinch roller and the right of the media.

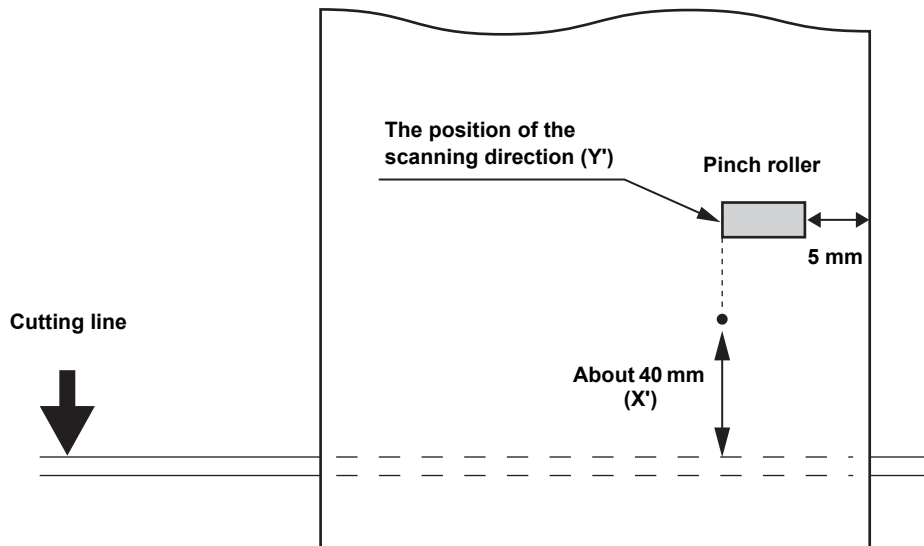

Test Printing

Print a test pattern to check that there are no discharging defects such as nozzle clogging (slight touching of ink or nozzle missing).

About test patterns

This machine provides you two test patterns.

● Normal test pattern (when using ink other than white ink)

When you use ink that you can check by printing a test pattern on a white media, print this test pattern.

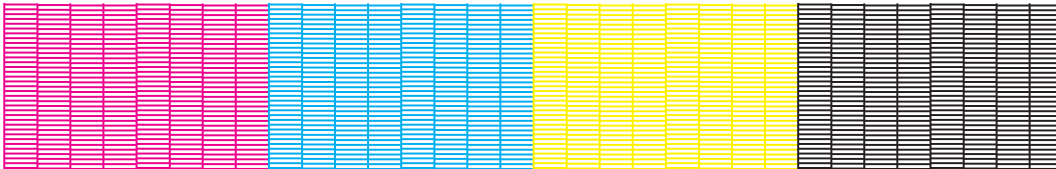

● Test pattern for checking white ink

When you use a white media and wish to check discharging status of white ink, print this test pattern.

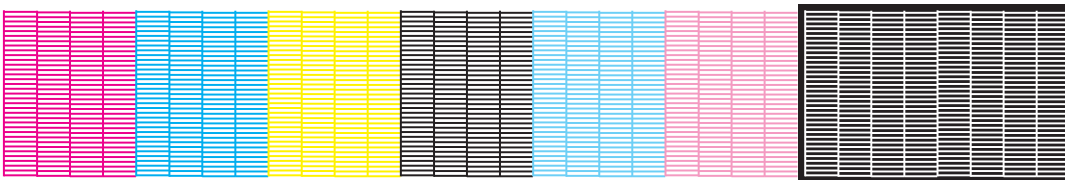

Note on test printing

Important!

- When using a leaf medium, set one that is larger than an A4-size medium in the longitudinal direction.
- When using a roll medium, rewind the medium by hand before printing so that it is not loose. When the roll medium has not been rewound tightly, it may cause image quality to deteriorate.
- When detecting the medium and the mode is in cut mode, if you perform test printing as it is, the following screen will be displayed by pressing the **TEST PRINT/TEST CUT** key in Step 2. In this case, press the **ENTER** key to switch the setting of pinch roller pressure to the print mode and then perform the test printing.
- If the **END** key is pressed, switching operation will not be performed.

```
! PR PRESSURE : CUT !  
SWITCH           : e n t
```

Perform test printing with the normal test pattern

Check before test printing.

- If a medium has been set (☞ P.2-15)
- If the origin position has been set
- If the head gap has been adjusted (☞ P.2-15)

1 Press the **(MODE CHANGE)** key in LOCAL to select the printing mode.

```
<LOCAL . 1>      [#01]
                WIDTH: ****mm
```

2 Press the **(TEST PRINT/TEST CUT)** key.

```
TEST PRINT
(FEED DIR.)  <ENT>
```

- Press **(▲)** **(▼)** to change the test pattern orientation. The orientation changed here returns to the orientation set in P.3-34 after the test printing has been complete.
- When performing test printing after having changed the orientation from "SCAN DIR." to "FEED DIR.", the line is fed to the position of the first test printing.
- For the details on the orientation of test printing, see P.3-34.

3 Press the **(ENTER)** key.

- Test printing starts.
- When printing has ended, the screen returns to LOCAL.

```
** TEST PRINT **
```

```
<LOCAL . 1>      [#01]
                WIDTH: ****mm
```

4 Check the result of the test printing.

- When the result is normal, end the operation.
- When the result is abnormal, perform head cleaning. (☞ P.2-39)

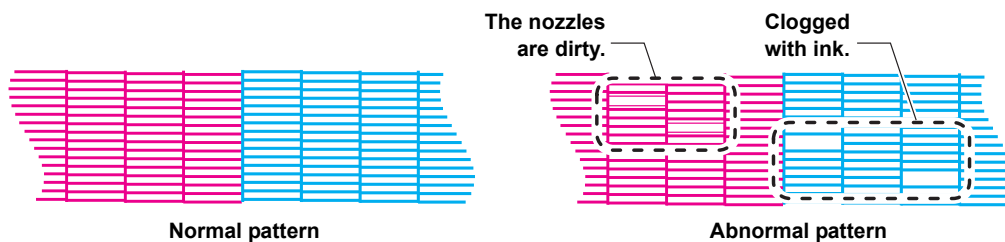

Perform test printing with the test pattern for checking white ink

Check before test printing.	• If a medium has been set (☞ P.2-15)	• If the origin position has been set
	• If the head gap has been adjusted (☞ P.2-15)	

1 Press the **(MODE CHANGE)** key in LOCAL to select the printing mode.

<LOCAL . 1> [#01]
 WIDTH : * * * * mm

2 Press the **(TEST PRINT/TEST CUT)** key.

TEST PRINT
 (FEED DIR.) <ENT>

3 Press the **(▲▼)** key to select the “(WHITE CHK.)”.

TEST PRINT
 (WHITE CHK.) <ENT>

4 Press the **(ENTER)** key.

* * TEST PRINT * *
 01 : 00

- Print a test pattern in the following orders.
- In the second line of the screen, remaining time from the start of printing is displayed.

- (1) Print the pattern daubed with black.
- (2) Dry the pattern for thirty seconds.
- (3) Return the media automatically and print the test pattern.

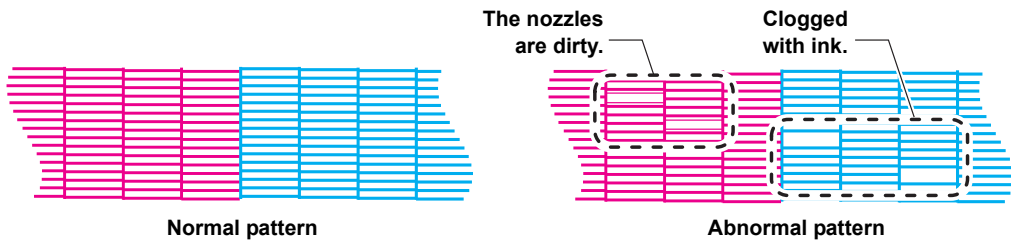

Check warning of white nozzle status (Only when using SS21 white ink)

As SS21 white ink is easier to cause nozzle clogging compared to other ink, you must keep the nozzle status normal even when you do not discharge it.

In order to keep the nozzle status normal, this machine displays the warning message in the right once a fortnight*¹.

```
Check the "W" nozzle
condition.      <ENT>
```

- The warning message will be displayed after the media detection is performed.
- When the warning message is displayed, perform the following:

1 When the warning message is displayed, press the **ENTER** key.

- The machine enters into the waiting for test printing status.

```
TEST PRINT
(WHITE CHK.)  <ENT>
```

2 Press the **▲** **▼** key to select the type of the test printing.

3 Press the **ENTER** key.

- Print the test pattern.

Important!

- After the warning message is displayed, when you perform "Perform test printing with the test pattern for checking white ink" (☞ the previous page) or "White Ink Maintenance Function" (☞ P.6-36), the warning will be released.
- When the warning message is displayed, you can cancel it by pressing the **END** key. However, after the next media detection is performed, the warning message will be displayed again.
- The warning message is displayed only when performing media detection in the printing mode.

*1. A fortnight after clearance of the warning message or maintenance of the white ink.

Head Cleaning

About head cleaning

There are two types of head cleaning.

● Depending on the test printing result, perform to solve nozzle clogging.

Check the printed test pattern result and perform cleaning depending on the status.

Select one from the three types below:

NORMAL : When any line is missing

SOFT : When only head wiping is needed (when lines are bent)

HARD : When poor image quality cannot be improved even by NORMAL or SOFT cleaning

● Perform when using silver ink or white ink of ES3 ink. (available for the firmware Ver.2.40 and later)

Pigments of silver ink and white ink of ES3 ink have nature of settling down when they are left for a long time without being used, and it may cause color heterogeneity.

By performing "spot" of head cleaning to discharge ink settling down, you can improve color heterogeneity (spot color maintenance function).

spot : By discharging special ink whose pigment remains settling down in the head, the damper or the tube of this machine, improve color heterogeneity.



- Spot color maintenance is selectable only when silver ink or white ink of ES3 ink has been filled for the firmware Ver.2.40 and later.



2

Basic Operations

Perform head cleaning depending on the test printing result

There are three types of head cleaning. Use one by checking the test pattern.

1

Press the **MODE CHANGE** key in LOCAL to select the printing mode.

<LOCAL . 1> [#01]
WIDTH : * * * * mm

2

Press the **CLEANING/FEED** key.

CLEANING
TYPE : NORMAL

3

Press **▲** **▼** to select a type of cleaning.

NORMAL : When any line is missing

SOFT : When only head wiping is needed (when lines are bent)

HARD : When poor image quality cannot be improved even by NORMAL or SOFT cleaning

CLEANING
TYPE : HARD

4

Press the **ENTER** key.

- The remaining cleaning time is indicated in the lower part of the display.
- When cleaning has ended, the screen returns to LOCAL.

CLEANING ACTIVE
00 : 00

5

Perform test printing again to check the result.

- Repeat the cleaning and test printing until the result becomes normal.



When image quality is not improved even though head cleaning is repeated:

- Clean the wiper and ink cap. (☞ P.6-6)
- Wash the nozzle head. (☞ P.6-11)
- See "When Nozzle Clogging Cannot Be Solved" to improve poor image quality. (☞ P.6-18)

Perform spot color maintenance

Perform this to solve color heterogeneity due to settling down of pigment when using silver ink or white ink of ES3 ink.

Spot color maintenance is selectable only when silver ink or white ink of ES3 ink has been filled for the firmware Ver.2.40 and later.



1 Press the **MODE CHANGE** key in LOCAL to select the printing mode.

<LOCAL . 1> [#01]
WIDTH : * * * * mm

2 Press the **CLEANING/FEED** key.

CLEANING
TYPE : NORMAL

3 Press **▲ ▼** to select [spot].

CLEANING
TYPE : spot

4 Press the **ENTER** key.

SPOT COLOR SELECT
COLOR : SILVER

5 By pressing **▲ ▼**, select the color on which you wish to perform maintenance.

SPOT COLOR SELECT
COLOR : WHITE

- Silver** : Perform maintenance only for silver ink.
- White** : Perform maintenance only for white ink.
- Silver & white** : Perform maintenance for silver ink and white ink at the same time.

6 Press the **ENTER** key.

REMOVE : INK CARTRIDGE
___W___

7 Remove the ink cartridge of the selected color.

- The lamp located above the cartridge lights to inform you of the ink cartridge to be removed.
- After the ink cartridge is removed, ink discharging starts.

* DISCHARGE *
03 : 00



- When discharging is completed, the screen on the right is displayed.

SHAKE INK CARTRIDGE
:ent

8

Slowly shake the removed ink cartridge more than twenty times right and left.

- To prevent ink from leaking when you shake the cartridge, wear gloves and firmly cover the A part of the upper surface of the cartridge and the B part of the bottom surface of the cartridge with paper towels. Then, shake it more than twenty times right and left so that ink flows inside the cartridge.



- If you shake it too strong, the pack inside may be damaged and it may cause ink leakage. Therefore, perform this carefully.
- If the remaining amount of ink is less, ink in the cartridge cannot be beaten enough. Tilt the cartridge until it becomes vertical.



A part
(the place to stick a
needle)

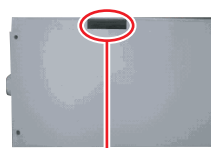

B part
(the slot on the
bottom)

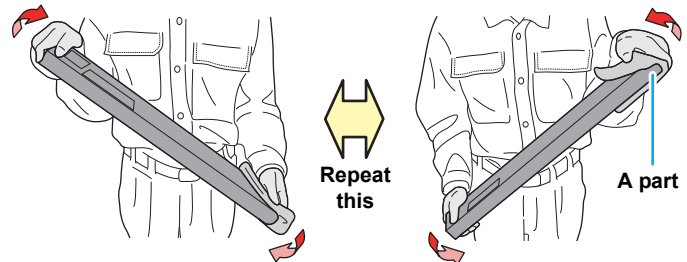

Cover with paper towel firmly and shake ink slowly

9

Press the **ENTER key.**

SET : INK CARTRIDGE
_ _ _ W _ _ _

10

Set the cartridge.

- After the cartridge is set, filling starts.
- When filling is completed, the screen returns to LOCAL.

FILLING UP
03 : 00



<LOCAL . 1> [#01]

About warning message display of performing spot color maintenance

When silver ink or white ink of ES3 ink is used and when ink has been left for two days and more without being used, to prevent color heterogeneity due to settling down of pigment, the message on the right is displayed on the screen.

- The warning message is displayed when you turn on the power supply after two days has passed from the silver ink had been used last time.
- Silver ink and white ink change their colors if they have been left for about two days.
- If the warning message is displayed, perform special color maintenance by following the procedures below:

PERFORM SPOT COLOR
MAINTENANCE? <ENT>



COLOR : SILVER

1

If the warning message is displayed, press the **ENTER key.**

- If you do not wish to perform spot color maintenance, press the **END** key to cancel the operation.

2

Press the **ENTER key.**

REMOVE : INK CARTRIDGE
_ S _ W _ _ _

3 Remove the ink cartridge of the displayed color on the screen.

- The lamp located above the cartridge lights to inform you of the ink cartridge to be removed.
- After the ink cartridge is removed, ink discharging starts.

* D I S C H A R G E *
03 : 00



- When discharging is completed, the screen on the right is displayed.

SHAKE INK CARTRIDGE
: e n t

4 Slowly shake the removed ink cartridge more than twenty times right and left.

- To prevent ink from leaking when you shake the cartridge, wear gloves and firmly cover the A part of the upper surface of the cartridge and the B part of the bottom surface of the cartridge with paper towels. Then, shake it more than twenty times right and left so that ink flows inside the cartridge.



- If you shake it too strong, the pack inside may be damaged and it may cause ink leakage. Therefore, perform this carefully.
- If the remaining amount of ink is less, ink in the cartridge cannot be beaten enough. Tilt the cartridge until it becomes vertical.

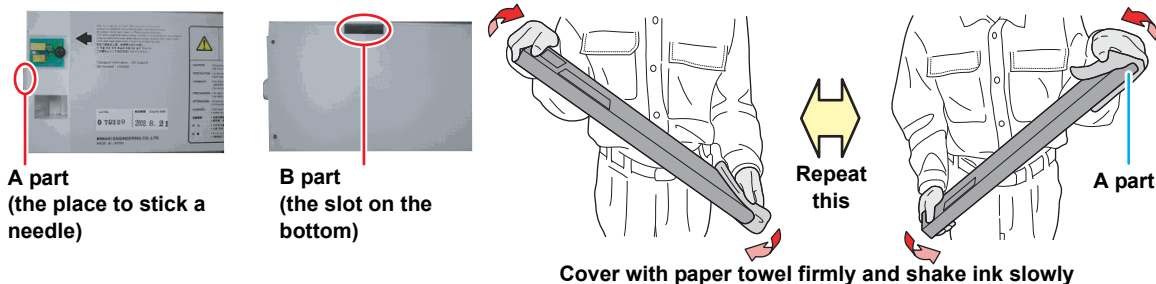

5 Press the **ENTER key.**

6 Set the cartridge.

- After the cartridge is set, filling starts.
- When filling is completed, the screen returns to LOCAL.

F I L L I N G U P
03 : 00



<LOCAL . 1> [#01]

Test Cutting

Test cutting is performed to check whether the settings for tool conditions are appropriate. In test cutting, two squares shown right are cut.

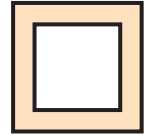

Important!

- When the cutter cuts badly because of the wear of the blade, the value of PRESSURE can be increased temporarily to deal with the problem.
(This should be done only temporarily. It is recommended that the blade of the cutter be replaced with a new one to maintain cutting quality.)
- Test cutting performs the operation at the current cutter position. (When there is not a cutter unit on the medium, test cutting is performed at the drawing origin.)
- When cutting the data after test cutting, the origin must be moved in advance. If you cut without moving the origin, there is a possibility of overlapping on the test cutting.
- When detecting the medium and the mode is in print mode, if you perform test cutting as it is, the following screen will be displayed by pressing the **TEST PRINT/TEST CUT** key in Step 2. In this case, press the **ENTER** key to switch the setting of pinch roller pressure to the cut mode and then perform the test cutting.
- If the **END** key is pressed, switching operation will not be performed.

```
! PR PRESSURE : PRINT !
SWITCH                : ent
```



- When the settings for tool conditions are appropriate, the result of the test cutting is as follows:
The two squares have been cut out completely.
The backing paper has not been cut.
The corners of the squares are not round.
The corners of the squares are not turned up.

1

Press the **MODE CHANGE** key in LOCAL to select the cutting mode.

```
<LOCAL . C>          [#01]
CUT1 ( 30 / 60 / 0.30)
```

2

Press the **TEST PRINT/TEST CUT** key.

```
TEST CUT
<ENT>
```

3

Press the **ENTER** key.

- Test cutting is performed.

```
** TEST CUT **
```

According to the result of the test cutting, configure the settings for the cutting condition again.

Symptom	Cause	Countermeasure
Some parts have not been cut.	The cutting speed is too high, the blade edge is lifted.	Reduce the speed. (☞ P.2-4)
		Tighten the knob of the tool holder further. (☞ P.2-12)
The backing paper of the medium is cut.	The cutting pressure is too high.	Reduce the pressure. (☞ P.2-4)
	The length of the blade edge drawn out is too long.	Adjust the length of the blade edge drawn out. (☞ P.2-11)
The corners of the square are round.	The OFFSET value is not appropriate.	Adjust the OFFSET value according to the state of the cutter you use. (☞ P.2-4)
The corners of the square are turned up.	The length of the blade edge drawn out is too long. The cutting pressure is high. [ADJ-PRS OFFSET] is large. Two or more of the above apply.	Adjust the length of the blade edge drawn out. (☞ P.2-11)
		Adjust the cutting pressure. (☞ P.2-4)
		Adjust the ADJ-PRS OFFSET value. (☞ P.4-37)



2

Basic Operations

Preparing for the Heaters

Changing the Temperature Settings for the Heaters

The temperature settings for the heaters can be changed and stored in P.3-12 "Changing the Temperature Settings for the Heaters".

Described here is how to change the already set temperature.

Set the heater temperature according to the characteristics of the media you use.

- The temperature of the heaters has been set to "OFF" as default.
- Appropriate temperature adjustment can be made because the temperature can be adjusted even during printing.
- It may take several minutes to tens of minutes for the set temperature to be reached, depending on the ambient temperature.

1 Press the **HEATER/CUTTER** key in LOCAL.

PRE	PRT	POST
35 °C	40 °C	50 °C

Screen for checking the heater temperature

2 Press the **HEATER/CUTTER** key.

40 °C	40 °C	50 °C
(OFF	OFF	OFF)

Temperature set in [HEATER] of the type registration

3 Press **▲ ▼ ◀ ▶** to set the temperature of each heater.

Heater selection : Select one with **◀ ▶**.
Temperature setting : Set the temperature with **▲ ▼**.

- The heater starts to get hot. (The [HEAT] lamp lights in orange.)

Set temperature: 20 to 50°C

40 °C	40 °C	50 °C
(OFF	OFF	OFF)

4 The heating of the heater stops.

- When the heater temperature reaches the set temperature, the [HEAT] lamp goes off and the [CONSTANT] lamp lights in green.

5 Press the **ENTER** key to stop heating.

- The screen returns to Local.



- You can register the temperature of the heaters beforehand according to the types of media you use. (P.3-2 "Registering All Printing Conditions Together (Type Registration)")
- The temperature set by the operation above is not reflected in the set values of the heaters whose types have been registered. The currently set temperature is not changed until the power is turned OFF or a new temperature is set on the following conditions:
 - (1) Change the type of the heater.
 - (2) Change the heater temperature according to P.3-12 "Changing the Temperature Settings for the Heaters".
 - (3) Specify the heater temperature from the PC.
- When the RIP you use has the function of controlling the heater temperature, the temperature can be controlled on the RIP side. (For how to control the temperature, see the instruction manual for the RIP you use.)

Important!

- Use this machine at a temperature between 20 to 35°C. The temperature may not reach the set value, depending on the ambient temperature.

Reference for Temperature Setting

Ink type	ES3 ink			SS21 ink
Media type	Glossy chloroethylene	Tarpaulin	FF	All media
Pre-heater setting	40°C	40°C	40°C	35°C
Print heater setting	40°C	40°C	40°C	35°C
Post-heater setting	50°C	50°C	50°C	50°C

Important!

- Adjust the temperature appropriately according to the state of the medium you use.

P

2

Basic Operations

Checking the Heater Temperature

1

Press **HEATER/CUTTER** on the operation panel.

- The current heater temperature is displayed.

PRE	PRT	POST
35 °C	40 °C	50 °C

2

Press **END** to end the checking.

- The screen returns to LOCAL.

Important!

- When switching the mode to the print mode after cutting data in the cut mode and pressing the **HEATER/CUTTER** key, "OFF" is displayed on each heater temperature. When pressing the **HEATER/CUTTER** key again, the temperature will go up to the set temperature.

Printing Data

Starting a Printing Operation

Important!

- When using a roll medium, rewind the medium by hand before printing so that it is not loose. When the roll medium has not been rewound tightly, it may cause the image quality to deteriorate.
- When switching the mode to the print mode after cutting data in the cut mode, "OFF" is displayed on each heater temperature. Press the **HEATER/CUTTER** key twice, and then raise the heater temperature up to the set temperature and perform printing.

1 Set a medium. (☞ P.2-15)

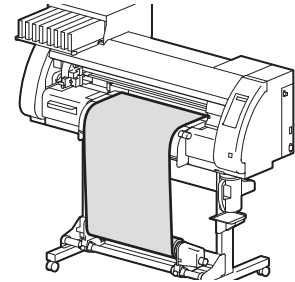

2 Check the heater temperature.

- Check the CONSTANT lamp lights in [PRE], [PRINT], and [POST] below the display.

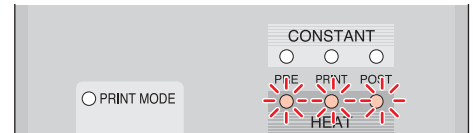

3 Press the **REMOTE** key in LOCAL.

- The screen changes to REMOTE, and data can be received from the PC.

TEMPERATURE CONTROL!
PLEASE WAIT

4 Transmit data to be printed from the PC.

- The pressure is switched automatically in concert with the pinch roller pressure set in P. 3-6 "Setting for the Pinch Rollers".
- The ACTIVE lamp blinks and the printing conditions are displayed.
- For the method of data transmission, see the instruction manual for the output software.

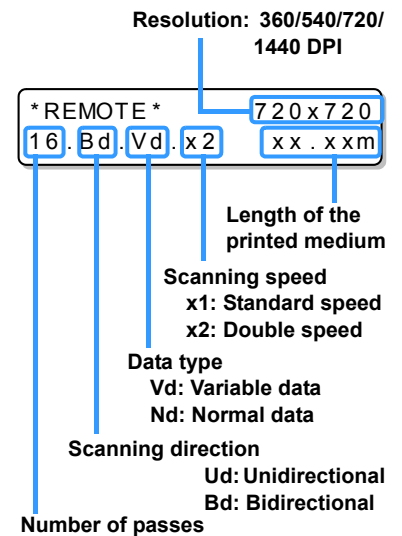

5 Start printing.

- The printing speed may change, depending on the width of the set medium or the position of the print origin even when the same data is printed. This is because of a difference in resolution.

P

Stopping a Printing Operation

Perform the following operation when stopping a printing operation halfway.

1

Press the **REMOTE** key during printing.

- The printing operation stops.
- Interrupt data sending at the PC side during the data is sent from the PC.
- Printing restarts from the interrupted data by repressing the **REMOTE** key.

```
<LOCAL . 1>      [#01]
                WIDTH: ****mm
```

P

2

Basic Operations

Deleting Received Data (Data Clear)

When you want to stop printing, delete the already received data.

1

Press the **DATA CLEAR** key in LOCAL.

```
DATA CLEAR      <ENT>
```

2

Press the **ENTER** key.

- The ACTIVE lamp goes off.
- The received data is deleted, and the present mode returns to LOCAL.

```
** DATA CLEAR **
```

Starting a Cutting Operation

Also when printing data with a pen, follow the procedure below.

1

When the machine is in a REMOTE state, the PC transmits data to be cut.

- The pressure is switched automatically in concert with the pinch roller pressure set in P. 4-3 "Setting for the Pinch Rollers".
- When the machine has received the data, the data starts the cutting automatically.
- When the cutting has been completed, the display appears as the one shown right.

```
*REMOTE . C*      [#01]  
CUT1 (30 / 60 / 0.30)
```

Stopping Cutting in a While

If you stop cutting or pen plotting in a while, perform the following operation.

1

Press the **REMOTE key while the machine is operating.**

- The operation of the machine stops in a while and it enters a local state.
- The time it takes for the operation of the machine to stop is different, depending on the data being processed.

When a circle is processed: After the circle has been processed, the operation stops.

Other line segments : After they have been processed by the unit of vector, the operation stops.

Restarting a Cutting Operation

1

Press the **REMOTE key to restart a cutting operation.**

- The machine enters a REMOTE state, and a cutting operation is restarted.

Functions That Can Be Set after a Cutting Operation Has Been Stopped

● Changing the tool condition

☞ "About Tool Conditions during Cutting" of P.2-3

● Stopping a cutting operation of the received data

☞ "Stopping a Cutting Operation (Data Clear)" of P.2-49

Stopping a Cutting Operation (Data Clear)

If you want to stop a cutting operation of the received data, clear the data.

- When clearing the data, the process will not restart even if you press the **REMOTE** key.
- After clearing the data, switching to the remote mode and receiving another data, new data will be cut.

1 Press the **DATA CLEAR** key in LOCAL.

DATA CLEAR
<ENT>

2 Press the **ENTER** key.

- The ACTIVE lamp goes out.
- The reception buffer is cleared, and the present mode returns to LOCAL.

** DATA CLEAR **



- Do not perform the data clearance during the data transmitting.
- Even after performing the data clearance, the received data is stored in the reception buffer. You can specify the data performed data clearance and perform Multiple Cuttings. (☞ P. 4-46)

Removing the Cutter Unit Temporarily

When cutting or printing-with-a-pen job is finished, the cutter unit is on the platen.

To check the result of cutting (printing-with-a-pen) or to set a new medium, follow the steps below to remove the cutter unit from the platen temporarily.

1 Press the **HEATER/CUTTER** key in LOCAL.

CUT HEAD RETRACT
<ENT>

2 Press the **ENTER** key.

- The cutter unit moves from on the platen to the left end of the machine.

PLEASE WAIT



2

Chapter 3

Extended Functions – Printer –



This chapter

describes the operation procedures for using the printing function more conveniently and each setting procedure.

About User Types	3-2	Setting Priority Order	3-22
Registering All Printing Conditions Together (Type Registration)	3-2	Setting Automatic Cleaning	3-24
How to Register User Types	3-2	Setting Cleaning during Printing	3-26
Setting the Pinch Rollers	3-5	Other Settings	3-27
Recommended Setting for the Pinch Roller Pressure	3-5	Copying the Set Contents	3-29
Quantity of Pinch Rollers	3-5	Initializing the Settings	3-30
Setting for the Pinch Rollers	3-6	Machine Settings	3-31
Setting Media Correction	3-8	Setting the DEODORIZE FAN	3-31
Setting Media Correction	3-8	Setting the DRYNESS FEED	3-32
If the Positions of Dots Shift	3-10	Stamp Setting	3-33
Changing the Set Values of the Heaters . 3-12		Setting the Test Print Arrange	3-34
Changing the Temperature Settings for the Heaters	3-12	Change the operation condition of the room temperature	3-35
Adjustment to an Appropriate Temperature	3-14	Extension of Ink Expiry Month	3-36
When the Heater Temperature Does Not Reach the Preset One	3-15	Switch Setting of Ink Supply Path	3-38
Setting the Printing Method	3-16		
Setting of Printing Quality	3-16		
Setting a Scanning Direction	3-18		
Setting Logical Seek	3-19		
Setting for White-laying Printing	3-20		
Setting Drying Time	3-21		

About User Types

Registering All Printing Conditions Together (Type Registration)

This machine allows you to register printing conditions in each of the user types (1 to 4). Register a printing condition according to each media that you use in a user type beforehand. When you replace one medium to another, you can set the optimum printing condition only by changing one user type to another.

Example of Type Registration

Type 1	For Tarpaulin1	Type 3	For FF (Flexible Face)
Type 2	For Tarpaulin2	Type 4	Polyvinyl chloride mat



How to Register User Types

- 1** Press the **MODE CHANGE** key in LOCAL to select the printing mode.
- 2** Press the **FUNCTION** key.
- 3** Press the **ENTER** key.
- 4** Press to select one of the types (1 to 4) and press the **ENTER** key.
- 5** Select and set each item of "List of Functions to Be Set".
 - For details on how to set each function, see the reference page contained in "List of Functions to Be Set in User Types".

List of Functions to Be Set in User Types

This section describes the overview of each function to be set and set values that can be registered in user types. The underlined has been set as default.

Function Name		Set Value	Overview	
PINCH ROLLER (☞ P.3-5)	ENDS	HIGH/MIDDLE/LOW	Used to set the pinch roller pressure.	
	INNER	HIGH/MIDDLE/LOW/OFF		
	No.	2 to 7	Used to set the number of the pinch roller at the left end of the medium.	
MEDIA COMP. (☞ P.3-8)		-255 to <u>0</u> to 255	Used to print a pattern for correcting a media-feeding rate and correct it.	
DROP. POS CORRECT (☞ P.3-10)		-40.0 to <u>0</u> to 40.0	Used to adjust the dot position in go and return printing.	
HEATER (☞ P.3-12)	SET TEMP.	PRE HEATER	OFF/ 20 to 50°C (OFF/ 68 to 122°F)	Used to set heater conditions.
		PRINT HEATER	OFF/20 to 50°C (OFF/68 to 122°F)	
		POST HEATER	OFF/20 to 50°C (OFF/68 to 122°F)	
	SET TIME	STANDBY	(NONE/0 to 90 min by the unit of 10 min)	
		OFF TIME	(NONE/0 to 90 min by the unit of 10 min)	
PRINT MODE (☞ P.3-16)	DRAFT QUALITY	<u>STD</u> / FAST / FINE	Used to set printing quality and a printing direction.	
	FINE QUALITY	<u>STD</u> / FAST / FINE		
	SCAN DIRECTION	Bi-D / <u>Uni-D</u>		
	LOGICAL SEEK	<u>ON</u> /OFF		
	WHITE LAY PRINT	<u>OFF</u> /ON (LEVEL1 to 3)		
INK LAYER (☞ P.3-27)		<u>1</u> to 9	Used to set the number of layers to which ink is applied.	
DRYING TIME (☞ P.3-21)	SCAN	<u>0.0</u> to 19.9 sec	Used to set the time for ink to dry.	
	PRINT END	<u>0</u> to 999 sec		
AUTO CUT (☞ P.3-27)		ON/ <u>OFF</u>	Used to cut the media automatically after printing.	
PRE-FEED(☞ P.3-27)		ON/ <u>OFF</u>	Used to feed a medium back and forth before printing. When a sticky medium is used, select ON.	
COLOR PATTERN (☞ P.3-27)		ON/ <u>OFF</u>	Used to print a color pattern on the right edge of a medium.	
REFRESH (☞ P.3-27)		LEVEL <u>0</u> (Long interval for refreshing) to 3 (Short interval for refreshing)	Used to refresh the print heads during printing.	
VACUUM (☞ P.3-27)		OFF / <u>STANDARD</u> / WEAK / LittleWEAK / STRONG	Used to set the ability to adsorb a medium.	
FEED SPEED LEVEL (☞ P.3-27)		10 to <u>100</u> to 200% 10%.....6 mm/sec 100%.....60 mm/sec 200%.... 120 mm/sec	Used to change the media-feeding speed during printing, etc.	





Function Name		Set Value		Overview
PRIORITY (☞ P.3-22)		INDIVIDUALLY / <u>ALL HOST</u> / ALL PANEL		Used to set the priority order of settings (by host/panel). Used to set the following items individually when the individual setting is selected. <ul style="list-style-type: none"> • Media correction • Heater • Printing method • Ink-laying printing • Drying time • Automatic Cutting • Pre-feed • Color pattern • Refreshing • VACUUM • Feeding speed level
AUTO CLEANING (☞ P.3-24)	ON	INTERVAL	10 to <u>1,000</u> to 10,000 mm	Used to set the automatic cleaning of the printing heads performed for each printing operation.
		TYPE	<u>NORMAL</u> / SOFT / HARD	
	<u>OFF</u>			
PRINT. CLEANING (☞ P.3-26)	ON	INTERVAL	10 to <u>1,000</u> to 10,000 mm	Used to set the automatic cleaning of the printing heads performed during printing.
		TYPE	<u>NORMAL</u> / SOFT / HARD	
	<u>OFF</u>			

Setting the Pinch Rollers

Set the pinch roller pressure and the pinch roller numbers according to the medium to be used.

Settings	Set Value	Overview
ENDS	HIGH	Set the pressure for the pinch rollers at both ends of the medium according to the medium to be used.
	MIDDLE	
	LOW	
INNER	HIGH	Set the pressure for the pinch rollers other than those at both ends of the medium according to usage.
	MIDDLE	
	LOW	
	OFF	
No.	2 to 7 *1	Set the number of the leftmost pinch roller according to the size of the medium to be used.

*1. The number of pinch rollers varies according to the machine type.

Recommended Setting for the Pinch Roller Pressure

The table below shows the recommended pinch roller pressure for printing:

Set pressure	Usage
ENDS : Middle INNER: Middle	For standard operation
ENDS : High INNER: Low	Use this combination of settings when you want to minimize the traces of pinch rollers on the medium. <ul style="list-style-type: none"> This setting may cause misalignment of the medium depending on the medium type, feeding rate, or medium width.



- When you use the machine under conditions other than the above, the medium may slip out of place during printing.
- Adjust the pinch roller pressure according to the situation.

Quantity of Pinch Rollers

The following table shows the quantity of the pinch rollers for each model. Check the pinch rollers on your machine for quantity.

Model	Quantity
CJV30-160	7 pieces
CJV30-130	6 pieces
CJV30-100	4 pieces
CJV30-60	3 pieces



Setting for the Pinch Rollers

This section describes the setting procedure for CJV30-160.
For CJV30-130/100/60, the number of pinch rollers set in Step 10 varies.

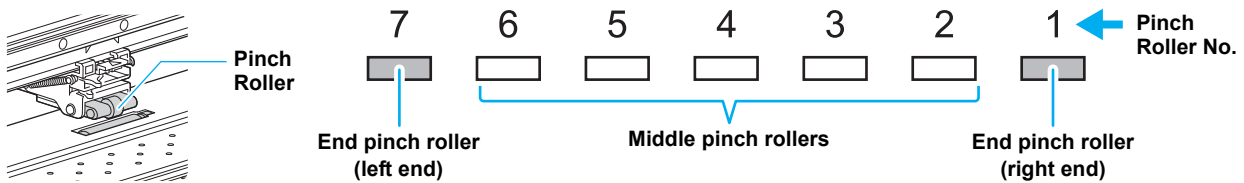
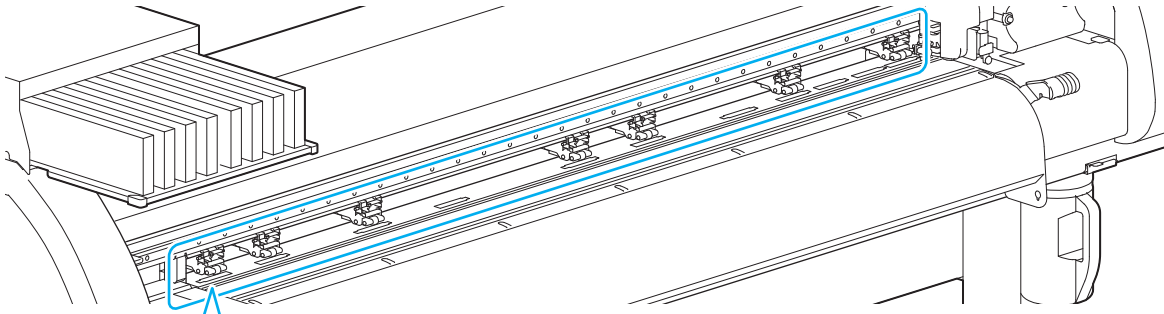

• The figure above shows CJV30-160.

- 1** Press the **MODE CHANGE** key in LOCAL to select the printing mode.

<LOCAL . 1> [#01]
WIDTH : * * * * mm

- 2** Press the **FUNCTION** key.

FUNCTION
SETUP <ENT>

- 3** Press the **ENTER** key.

SETUP
SELECT : TYPE . 1

- 4** Press **▲ ▼** to select one of the types (1 to 4) and press the **ENTER** key.

- 5** Press the **ENTER** key.

ENDS : **H**IGH [H _ _ _ H]
INNER : OFF No . 7 - 1

- 6** Press **▲ ▼** to set the pressure for the pinch rollers at both ends of the medium.



ENDS : **M**ID . [H _ _ _ H]
INNER : OFF No . 7 - 1

• Set value: HIGH/MID./LOW

- 7** Press **▶** to move the cursor to the middle pinch roller setting.

ENDS : MID . [H _ _ _ H]
INNER : **O**FF No . 7 - 1

8

Press   to set the pressure for the middle pinch rollers.

• Set value: HIGH/MID./LOW/OFF



```
ENDS :MID. [H____H]
INNER: MID. No. 7-1
```

9

Press  to move the cursor to the pinch roller number setting.

```
ENDS :MID. [H____H]
INNER: MID. No. 7-1
```

10

Press   to set the number of the pinch roller at the left end of the medium.

• Set value: 2 to 7

```
ENDS :MID. [__H__H]
INNER: MID. No. 4-1
```

11

Press the  key.

12

Press the  key several times to end the setting.

Important!

• Pinch roller pressure set here is reflected to the medium in the following condition:

- When print/cut remotely
- When detecting the medium next
- If you wish to reflect the set value to the medium currently set, detect the medium again by moving the clamp lever up and down.
- When printing in the local mode such as the dot position correction or medium correction, perform the steps from Step 1 and set the pinch roller pressure again.

Advanced Setting for the Middle Pinch Rollers

Advanced setting is available for the middle pinch rollers according to the medium to be used.

1



Perform the operations in Steps 1 to 10 in P.3-6 "Setting for the Pinch Rollers".

2

Press the  key.

```
ENDS :MID. [H____H]
INNER: MID. No. 7-1
```

3

Press   to select a pinch roller to set, and press   to set the advanced setting.

```
ENDS :MID. [H__L__H]
INNER: MID. No. 7-1
```

4

Press the  key.

5

Press the  key several times to end the setting.

Setting Media Correction

In the following cases, be sure to set medium correction and correct the amount of the medium feeding.

- when replacing the kind of the medium (☞ P.2-15)
- when changing the heater temperature (☞ P.2-44)
- when changing the pinch roller pressure in the pinch roller setting (☞ P.3-6)

If the correction value is not appropriate, stripes may appear on the printed image, thus resulting in a poor printing.

Important!

- When you have changed the temperature of the heaters, make sure that the [CONSTANT] lamp lights up and that the preset temperature is reached, and then start the correction.
- When printing with a take-up device, set the medium first and then perform media correction.

Setting Media Correction

A pattern for media correction is printed and a medium-feeding rate is corrected.



- Two bands are printed in the correction pattern.
- Make adjustment so that an even color density is obtained in the boundary between the two bands.

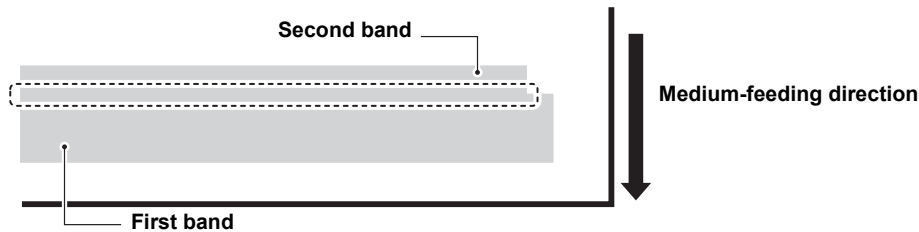

Important!

- When detecting the medium and when the mode is in cut mode, if you correct the medium as it is, the following screen will be displayed by pressing the **ENTER** key in Step 7. In this case, press the **ENTER** key to switch the setting of pinch roller pressure to the print mode and then print the correction pattern.
- If the **END** key is pressed, switching operation will not be performed.

```
! PR PRESSURE : CUT !
SWITCH           : e n t
```

1 Set a medium. (☞ P.2-15)

2 Press the **MODE CHANGE** key in LOCAL to select the printing mode.

```
<LOCAL . 1>      [#01]
                  WIDTH : * * * * mm
```

3 Press the **FUNCTION** key.

```
FUNCTION
SETUP           <ENT>
```

4 Press the **ENTER** key.

```
SETUP
SELECT          : TYPE . 1
```

5 Press **▲** **▼** to select one of the types (1 to 4) and press the **ENTER** key.

6 Press   to select [MEDIA COMP.].

```
[ 1 ]
MEDIA COMP.      <ent>
```



7 Press the  key.

```
[ 1 ] MEDIA COMP.
PRINT START      :ent
```

8 Press the  key to print a correction pattern.

```
PRINTING
PLEASE WAIT
```

9 Check the correction pattern and enter a correction value.

- Press the   to enter a correction value.
Enter a correction value in "+": The boundary between the two bands is widened.
Enter a correction value in "-": The boundary between the two bands is narrowed.
- When you change the correction value by "10", the width of the boundary changes by about 0.1 mm.

```
[ 1 ] MEDIA COMP.
VALUE           = 0
```

10 Press the  key twice.

- Print a correction pattern again and check it.
- When media correction is needed, perform the operation in Step 9 to make correction.
- Press the  key several times to end correction.

```
[ 1 ] MEDIA COMP.
PRINT START      :ent
```

Correcting Media-feeding during Printing

A media-feeding rate can be corrected even in the remote mode or when image data is printed.

1 Press the  key in the remote mode.

```
FEED COMPENSATION .
0
```



2 Press the  key.

```
FEED COMPENSATION .
0 > 1
```

3 Press   to enter a corrected feeding rate.



- Corrected feeding rate: -500 to 500
- The value entered here is reflected in the corrected feeding rate soon.

4 Press the  key.

- When you press the  key instead of the  key, the value entered here will be invalid.

```
FEED COMPENSATION .
SAVE                :ent
```

5 Press the  key.

- The changed value is registered.
- When you press the  key instead of the  key, the value entered here will be valid temporarily. (When you perform media detection again or turn the power OFF, the correction value is cleared.)

This indicates that media correction was made in the remote mode.

```
*REMOTE . : +*      [ # 0 1 ]
                ** . **mm
```

If the Positions of Dots Shift...

When the condition for printing (medium thickness/head height/setting of pinch roller pressure/ink type/etc.) has been changed, perform the following operation to correct the ink drop position for bidirectional (Bi) printing and obtain the proper printing result.

Important!

- When detecting the medium and when the mode is in cut mode, if you correct the dot position as it is, the following screen will be displayed by pressing the **ENTER** key in Step 7. In this case, press the **ENTER** key to switch the setting of pinch roller pressure to the print mode and then print the pattern.
- If the **END** key is pressed, switching operation will not be performed.

```
! PR PRESSURE : CUT !
SWITCH           : ent
```

Example of a Printed Pattern

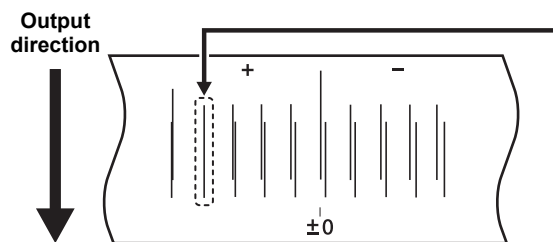

The fourth in the + direction from the 0 position is indicated as a straight line. In this case, the dot position correction value is 4.0.

1

Set a medium on the machine and set a printing origin. (☞ P. 2-15, P. 2-33)

- In order to print a pattern, a medium that is 500 mm wide and at least 400 mm long is necessary.

2

Press the **MODE CHANGE** key in LOCAL to select the printing mode.

```
<LOCAL . 1>      [#01]
                WIDTH : ****mm
```

3

Press the **FUNCTION** key.

```
FUNCTION
SETUP           <ENT>
```

4

Press the **ENTER** key.

```
SETUP
SELECT         : TYPE . 1
```

5

Press **▲** **▼** to select one of the types (1 to 4) and press the **ENTER** key.

6

Press **▲** **▼** to select [DROP.POScorrect].

```
[ 1 ]
DROP . POScorrect <ent>
```

7

Press the **ENTER** key.

```
[ 1 ] DROP . POScorrect
PRINT START    : ent
```

8

Press the **ENTER** key to start pattern printing.

- Multiple test patterns are printed. (The printed patterns are called Pattern 1, Pattern 2, Pattern 3... in the order of printing.)

```
PRINTING
PLEASE WAIT
```

9

Press   to correct the dot position of Pattern 1.

- Correction value: -40 to 40
- Check the test patterns. The position where an outward feeding line and a return feeding line become one straight line is the correction value.
- When the correction value is not between -40 and 40, adjust the height of the printing heads and then perform the operations in Step 2 and later.
- 2 types of the correction value is available depending on the head height.

Displays the current head height.
(H)... High (thick)
(L)... Low (thin)

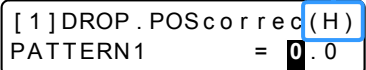

[1] DROP . POS cor rec (H)
PATTERN1 = 0 . 0

10

Press the  key.

11

In the same way as in Step 9, correct the dot position in Pattern 2 and subsequent patterns and press the  key.

12

Press the  key several times to end the correction.

P

3

Extended Functions – Printer –

Changing the Set Values of the Heaters

Reference for Temperature Setting

Ink type	ES3 ink			SS21 ink
Media type	Glossy chloroethylene	Tarpaulin	FF	All media
Pre-heater setting	40°C	40°C	40°C	35°C
Print heater setting	40°C	40°C	40°C	35°C
Post-heater setting	50°C	50°C	50°C	50°C



- Adjust the temperature appropriately according to the state of the medium you use.

Changing the Temperature Settings for the Heaters

Here, each item of "SET TEMP." and "SET TIME" is set.

Temperature setting (SET TEMP.)		Used to change the set temperature of the pre-heater, print heater, and post-heater inside the platen.
Time setting *1 (SET TIME)	STANDBY	Used to set the time it takes until the temperature of the heaters falls to reach the preheat temperature after printing has been complete. Set value: NONE, 0 to 90 min (by the unit of 10 min) <ul style="list-style-type: none"> The preheat temperature has been preset and cannot be changed. If the machine receives data with the preheat temperature reached, the heaters automatically raise their temperature up to the set temperature, and then the machine starts printing. When the set value has been set to "NONE", the heaters do not lower their temperature to the preheat one.
	OFF TIME	The heaters are turned off in the following cases: <ul style="list-style-type: none"> When printing is not performed longer than the preset time in the standby mode When printing is not performed longer than the preset time after printing has been completed with "NONE" being selected for the set value of "STANDBY" Set value: NONE, 0 to 90 min (by the unit of 10 min) If the machine receives data with the heaters turned off, the heaters are automatically turned on to raise their temperatures up to the preset levels and then the machine starts printing. <ul style="list-style-type: none"> When "NONE" is selected for the set value, the heaters are not turned off. When "0 min" is set for the set value, the heaters are turned off after printing has been complete.

*1. The time set here is valid only when the printing is completed. The value when print & cut operation or cutting operation is completed is different depending on the application software (RasterLinkPro4 or later, FineCut7 or later) you use.

1

Press the **MODE CHANGE** key in LOCAL to select the printing mode.

<LOCAL . 1> [# 0 1]
WIDTH : * * * * mm

2

Press the **FUNCTION** key.

FUNCTION
SETUP <ENT>

3

Press the **ENTER** key.

SETUP
SELECT : TYPE . 1

4

Press **▲** **▼** to select one of the types (1 to 4) and press the **ENTER** key.

- 5** Press to select [HEATER].

[1]
HEATER <ent>
- 6** Press the key twice.
• The heater temperature setting screen appears.

PRE	PRT	POST
25 °C	25 °C	35 °C
- 7** Press to set the temperature of each heater.
Heater selection: Select one with .Temperature setting: Set the temperature with .

PRE	PRT	POST
35 °C	40 °C	50 °C

Set temperature: 20 to 50°C
- 8** Press the key.

[1] HEATER
SET TEMP. <ent>
- 9** Press to select [SET TIME].

[1] HEATER
SET TIME <ent>
- 10** Press the key.

STANDBY	: OFF TIME
10min	: NONE
- 11** Press to set time.
Item selection: Select one with .Time setting: Set time with .

STANDBY	: OFF TIME
10min	: NONE

Set value: NONE, 0 to 90 min
(by the unit of 10 min)
- 12** Press the key.
- 13** Press the key several times to end the setting.
• The screen returns to LOCAL.

Important!

- Use this machine at a temperature between 20 to 35°C. The temperature may not reach the set value, depending on the ambient temperature conditions.

Adjustment to an Appropriate Temperature

This section describes how to adjust the temperature of the heaters to an appropriate one. Because the heater temperature should be different, depending on the types of media, ambient temperature, etc., set an appropriate temperature for each medium. For non-coated media or media on which ink is slow to dry, increase the heater temperature so that the ink fixing and drying characteristics can be improved. Check the items in the following method to set an appropriate temperature.

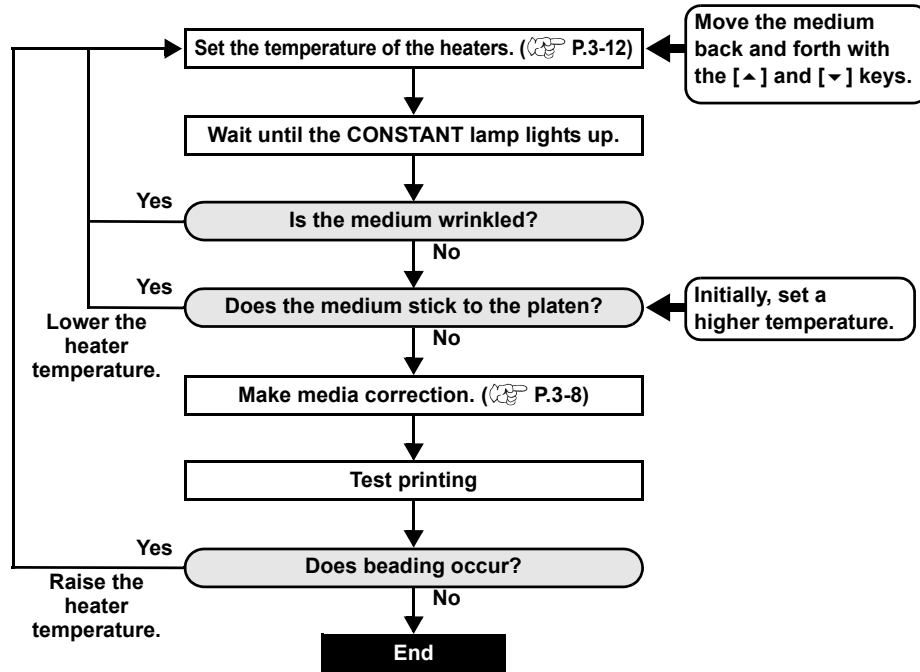

When the Heater Temperature Does Not Reach the Preset One

When the heater temperature is too low or the ink capacity (ink limit) is too small, printing failures, such as beading and banding, may occur.

Beading is a phenomenon that adjacent dots attract and stick to one another. Beading causes speckled patterns or stripes along printing passes (banding).

Example of Beading

The area in the vicinity of 100% magenta looks fine. Generally, the area in the vicinity of 70-100% single color is easily affected by the unevenness of a media feeding rate. The print shown here, free from unevenness of color in the vicinity of 100% magenta area, shows that media-feeding has been adjusted appropriately.

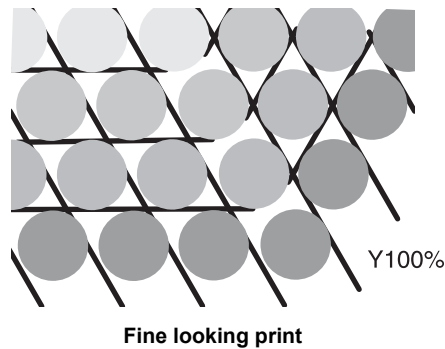

In the blue area (100% magenta + 100% cyan), however, speckled patterns and banding have occurred. This banding is a result of beading. When the heater temperature is low or the ink capacity (ink limit) of a medium is small, the first dot does not solidify before the second dot lands on the medium. As a result, dots stick to one another and unevenness or banding occurs.

In order to prevent beading, it is recommended to raise the heater temperature to increase the ink capacity (ink limit) of the medium, to adjust the ink volume per dot for the medium, to increase the number of printing passes and decrease the ink amount for one shot, and/or to gain time by scan wait.

Change the medium if none of the above-mentioned measures works to prevent beading.

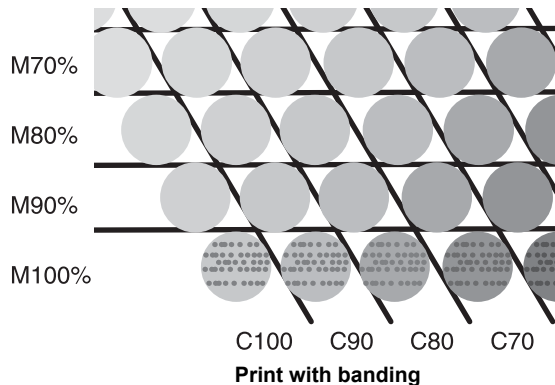

Setting the Printing Method

In the printing method setting, the following items are set:

- **Printing quality (DRAFT)** : Printing quality in the DRAFT mode (resolution in the scanning direction: 540 dpi) is set.
- **Printing quality (FINE)** : Printing quality in the FINE mode (resolution in the scanning direction: 720 dpi) is set.
- **Scanning direction** : A printing direction is set.
- **Logical seek** : ON/OFF of Logical seek is set.
- **White-laying printing** : When using white ink (SS21W-2), the printing method for other colors after white ink printing is set.

Setting of Printing Quality

Set Item	Set Value	Overview
DRAFT QUALITY	STD. / FAST / FINE	Used to select an image quality for printing.
FINE QUALITY		

1

Press the **(MODE CHANGE)** key in LOCAL to select the printing mode.

<LOCAL . 1> [#01]
WIDTH: * * * * mm

2

Press the **(FUNCTION)** key.

FUNCTION
SETUP <ENT>

3

Press the **(ENTER)** key.

SETUP
SELECT : TYPE . 1

4

Press **(▲)** **(▼)** to select one of the types (1 to 4) and press the **(ENTER)** key.

5

Press **(▲)** **(▼)** to select [PRINT MODE].

[1]
PRINT MODE <ent>

6

Press the **(ENTER)** key.

[1] PRINT MODE
DRAFT QUALITY <ent>

7

Select items to set.

- (1) Press **(▲)** **(▼)** to select [DRAFT QUALITY] or [FINE QUALITY].
([DRAFT QUALITY] is selected here.)
- (2) Press **(ENTER)**.

8

Press **(▲)** **(▼)** to select a printing quality.

- **Set value:** STD./ FAST/ FINE

- When ending the setting here, press the **(ENTER)** key to proceed to Step 11.

[1] PRINT MODE
DRAFTquality: **S**TD.

9 When changing the details of printing quality in each resolution, press **FUNCTION** to select a resolution.

[1] DRAFT QUALITY
540x720 <ent>

- (1) Press **▲** **▼** to select a resolution.
- (2) Press **ENTER**.

• **Set value:** 540 x 720, 540 x 900, 540 x 1,080 dpi (when DRAFT is selected)
720 x 540, 720 x 720, 720 x 1,080, 720 x 1,440 dpi (when FINE is selected)

10 Select the number of passes and a printing speed.

[1] DRAFT QUALITY
PASS=8 : SCAN=Hi SPEED

- (1) Select the number of passes with **▲** **▼** and press **▶**.
- (2) Select a printing speed (Fast or Standard) with **▲** **▼**.
- (3) Press **ENTER**.

• The set value for the number of passes is different, depending on the content of ink setting or the resolution selected in Step 8. See "Combination of Factors That Can Be Set" to select the number of passes.

11 Press the **END** key several times to end the setting.



Combination of Factors That Can Be Set

When changing the details of printing quality in Steps 9 and 10 of "Setting of Printing Quality", see the table below to set printing quality.

Resolution (dpi)	DRAFT quality			
	4 colors		6 colors	
	Pass	Speed	Pass	Speed
540 x 720 dpi	4	Fast/Standard	8	Fast/Standard
	8		16	
	16		32	
540 x 900 dpi	10	Fast/Standard	10	Fast/Standard
	20		20	
	40		40	
540 x 1,080 dpi	6	Fast/Standard	12	Fast/Standard
	12		24	
	24		48	

Resolution (dpi)	FINE quality			
	4 colors		6 colors	
	Pass	Speed	Pass	Speed
720 x 540	6	Fast/Standard	6	Fast/Standard
	12		12	
	24		24	
720 x 720	4	Fast/Standard	8	Fast/Standard
	8		16	
	16		32	
720 x 1,080	6	Fast/Standard	12	Fast/Standard
	12		24	
	24		48	
720 x 1,440	8	Fast/Standard	16	Fast/Standard
	16		32	
	32		64	

Setting a Scanning Direction

Set Value	Overview
Bi-D	Printing is performed in both outward and return directions of the printer unit. Select this when you want to print in a shorter period of time.
Uni-D	Printing is performed only in the outward direction of the printer unit. Select this when you want to print finer.

1 Perform the operations in P.3-16 Steps 1 to 6.



```
[1]PRINT MODE
DRAFT QUALITY <ent>
```

2 Press   to select [SCAN DIRECTION].

```
[1]PRINT MODE
SCAN DIRECTION <ent>
```

3 Press the  key.

```
[1]PRINT MODE
ScanDIRECTION:Bi-D
```

4 Press   to select a scanning direction.
• Set value : Bi-D, Uni-D

```
[1]PRINT MODE
ScanDIRECTION:Uni-D
```

5 Press the  key.

```
[1]PRINT MODE
SCAN DIRECTION <ent>
```

6 Press the  key several times to end the setting.



Setting Logical Seek

Set Value	Overview
ON	The printer unit moves according to the size of the data during printing. Select this when you want to print in a shorter period of time.
OFF	The printer unit moves from the right edge to the left edge of a medium, regardless of the size of the data. When you use a medium on which ink is hard to dry, you can have a longer drying time.

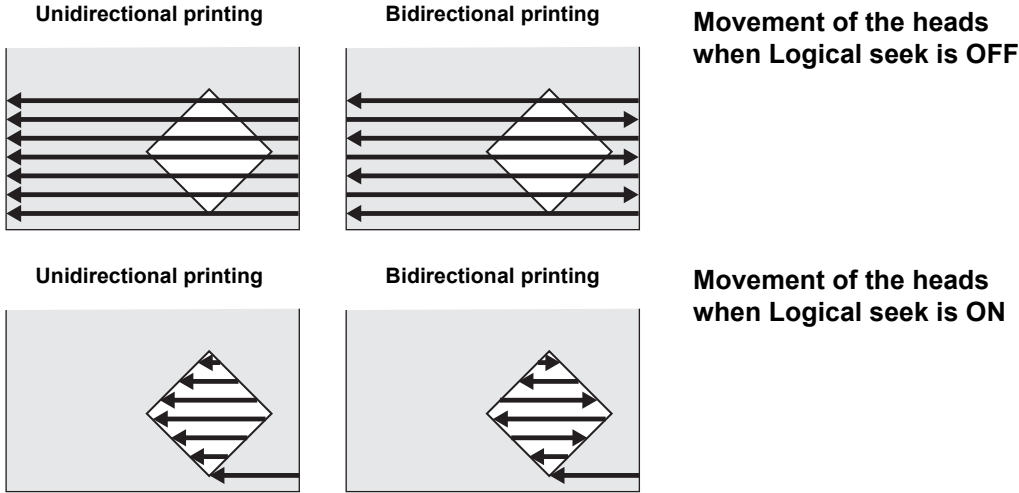

- 1** Perform the operations in P.3-16 Steps 1 to 6.

[1]PRINT MODE
 DRAFT QUALITY <ent>

- 2** Press to select [LOGICAL SEEK].

[1]PRINT MODE
 LOGICAL SEEK <ent>

- 3** Press the key.

[1]PRINT MODE
 LOGICAL SEEK :

- 4** Press to select ON/OFF.

[1]PRINT MODE
 LOGICAL SEEK :

- 5** Press the key.

[1]PRINT MODE
 LOGICAL SEEK <ent>

- 6** Press the key several times to end the setting.

Setting for White-laying Printing

When using SS21W-2 (SPC-0504W-2) white ink, you can print with other colors after printing with white ink. This section describes the method of printing with white ink and other color inks.

Set Value	Overview
OFF	White ink and other color inks are printed at the same time.
ON (LEVEL1 to 3*1)	Color inks are printed on the white ink a while after the white ink has been printed. <ul style="list-style-type: none"> If a larger number is set for LEVEL1 to 3, the time between printing white ink and printing color inks becomes longer. If a large number is set for LEVEL, the drying property of white ink improves, but printing time becomes longer.

*1. With this machine, you cannot set the order of synthesis.

Important!

- This function can be set only when SS21W-2 ink (6 colors + white) has been filled.
- Printing time is at least two times longer than that of normal printing.
- When printing is performed under the following conditions, the printing speed decreases because the number of nozzles to be used is limited.

Setting of Printing Quality	Resolution	Printing Width
DRAFT	540 x 1,080 dpi	1,541 mm or more
FINE	720 x 1,080 dpi	1,155 mm or more
	720 x 1,440 dpi	
	1,440 x 1,440 dpi	1,155 mm or more (577 mm for Vd data)

1 Perform the operations in P.3-16 Steps 1 to 6.



[1] PRINT MODE
DRAFT QUALITY <ent>

2 Press   to select [WhiteLayPrt.].

[1] PRINT MODE
WhiteLayPrt. <ent>

3 Press the  key.

[1] PRINT MODE
SETUP :  OFF

4 Press   to select the printing method.
• Set value: OFF, ON (LEVEL 1 to 3)

[1] PRINT MODE
SETUP :  ON (LEVEL 1)

5 Press the  key.

[1] PRINT MODE
WhiteLayPrt. <ent>

6 Press the  key several times to end the setting.

Setting Drying Time

The following items for ink drying time are set.

Set Item	Set Value	Overview
SCAN	0.0 to 19.9 sec	Ink drying time for each scanning is set. (During bidirectional printing, the machine stops for a certain period of time specified for each of the outward and return scanning.)
PRINT END	0 to 8 hours	Ink drying time after printing has been complete is set. (The next printing is not performed until the set drying time passes.)

- 1** Press the **MODE CHANGE** key in LOCAL to select the printing mode.

<LOCAL . 1> [# 0 1]
 WIDTH : * * * * mm
- 2** Press the **FUNCTION** key.

FUNCTION
 SETUP <ENT>
- 3** Press the **ENTER** key.

SETUP
 SELECT : TYPE . 1
- 4** Press **▲ ▼** to select one of the types (1 to 4) and press the **ENTER** key.
- 5** Press **▲ ▼** to select [DRYING TIME].

[1]
 DRYING TIME <ent>
- 6** Press the **ENTER** key.

SCAN : PRINT END
 0 . 0 s : 0 h 0 0 m 0 0 s
- 7** Press **▲ ▼ ◀ ▶** to set drying time.
 Item selection: Select one with **◀ ▶**.
 Time setting: Set time with **▲ ▼**.

Scanning: 0.0 to 19.9 sec

After printing: 0 to 8 hours

SCAN : PRINT END
 0 . 0 s : 0 h 0 0 m 0 0 s
- 8** Press the **ENTER** key.

[1]
 DRYING TIME <ent>
- 9** Press the **END** key several times to end the setting.

Setting Priority Order

It is determined which is prioritized for printing, the setting by the machine (panel) or the setting by the PC (host).

Set Value	Overview
INDIVIDUALLY	It is determined which is prioritized for the items below this table, the setting by this machine (panel) or the setting by the PC (host).
ALL HOST	The setting by the PC (host) for the items below this table is prioritized.
ALL PANEL	The setting by this machine (panel) for the items below this table is prioritized.

Items to be selected :Media correction / Heater / Printing method / Ink-laying printing / Drying time / Automatic cutting / Pre-feed / Color pattern / Refreshing / Adsorption / Feeding speed level



- 1** Press the **MODE CHANGE** key in LOCAL to select the printing mode.

<LOCAL . 1> [#01]
 WIDTH : * * * * mm
- 2** Press the **FUNCTION** key.

FUNCTION
 SETUP <ENT>
- 3** Press the **ENTER** key.

SETUP
 SELECT : TYPE . 1
- 4** Press **▲ ▼** to select one of the types (1 to 4) and press the **ENTER** key.
- 5** Press **▲ ▼** to select [PRIORITY].

[1]
 PRIORITY <ent>
- 6** Press the **ENTER** key.

[1] PRIORITY
 SETUP : **A**LL HOST
- 7** Press **▲ ▼** to select one of the set values.

 - Set value :INDIVIDUALLY/ ALL HOST / ALL PANEL
 - When selecting [INDIVIDUALLY], proceed to Step 8. When selecting [ALL HOST] or [ALL PANEL], press the **ENTER** key and proceed to Step 12.

[1] PRIORITY
 SETUP : **I**NDIVIDUALLY
- 8** Press the **FUNCTION** key.

 - The setting screen of media correction appears.

[1] PRIORITY
 MEDIA COMP. : **H**OST
- 9** Press **▲ ▼** to select "HOST" or "PANEL".

[1] PRIORITY
 MEDIA COMP. : **P**ANEL
- 10** Press the **ENTER** key.

 - You can move between items also by pressing **◀ ▶**. However, unless you press the **ENTER** key, the set value is not determined.

11 Perform the same operations as in Steps 9 and 10 to set other items.

12 Press the  key several times to end the setting.



- Even with the setting by the host being prioritized, the items set by the panel become effective if they have not been specified by the host.

Setting Automatic Cleaning

You can set items so that the head cleaning is automatically performed when printing has been completed for the set length.

When printing has been completed, the machine measures the length of a medium printed after the previous head cleaning and performs the cleaning automatically if necessary.

The machine can perform a stable printing operation with its heads always kept clean.

Cleaning is performed before the first printing after the machine has started. Then subsequent cleaning is performed according to the length (by the unit of meter) of a printed medium.

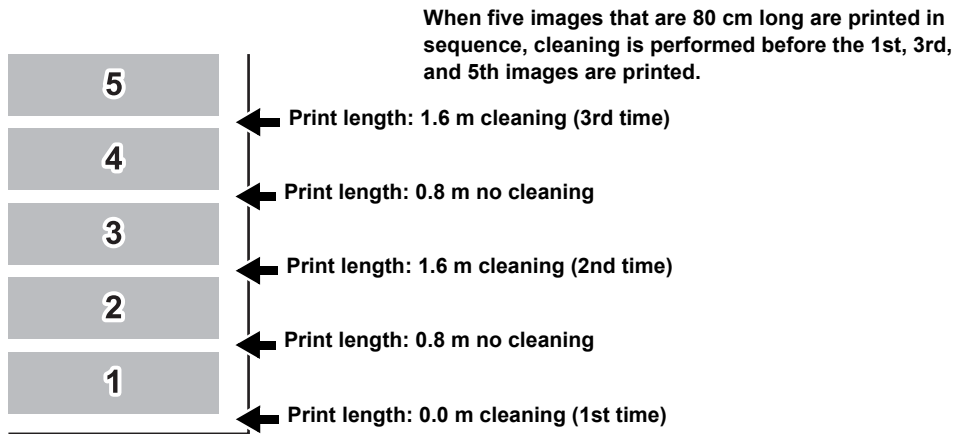

When the operation interval is 1,000 mm (example)

Set Item	Set Value	Overview
INTERVAL	10 to 1,000 mm	Interval between each automatic cleaning operation (print length)
TYPE	NORMAL / SOFT / HARD	A cleaning type is selected.

1 Press the **MODE CHANGE** key in LOCAL to select the printing mode.

<LOCAL . 1> [#01]
WIDTH : * * * * mm

2 Press the **FUNCTION** key.

FUNCTION
SETUP <ENT>

3 Press the **ENTER** key.

SETUP
SELECT : TYPE . 1

4 Press **▲** **▼** to select one of the types (1 to 4) and press the **ENTER** key.

5 Press **▲** **▼** to select [AUTO CLEANING].

[1]
AUTO CLEANING <ent>

6 Press the **ENTER** key.

[1] AUTO CLEANING
SETUP : OFF

7 Press **▲** **▼** to select ON.

• When selecting OFF, proceed to Step 9.

[1] AUTO CLEANING
SETUP : ON

8

Press the **FUNCTION** key.

INTERVAL	: TYPE
1000mm	: NORMAL

9

Press **▲ ▼ ◀ ▶** to set a cleaning interval and a cleaning type.

Item selection : Select one with **◀ ▶**.

Setting of an interval and type :

Set an interval and type with **▲ ▼**.

INTERVAL:	TYPE :
10 to 10,000 mm	NORMAL SOFT HARD

INTERVAL	: TYPE
1000mm	: NORMAL

10

Press the **ENTER** key.

11

Press the **END** key several times to end the setting.

Important!

- This function does not operate when ink near-end occurs. See P.1-14 "Changing an Ink Cartridge" to solve ink near-end.
- Depending on the state of the heads, etc., the image quality deterioration may not be improved even with this function performed. In this case, contact our service office or the distributor in your region.

Setting Cleaning during Printing

It is set whether head cleaning is performed automatically during printing.

In cleaning during printing, a cleaning interval is set according to the length of a printed medium.

Printing is interrupted each time a medium is printed for the set length, and head cleaning is performed automatically during the interval.

Set Item	Set Value	Overview
INTERVAL	10 to 1,000 mm	Interval between each cleaning operation (print length)
TYPE	NORMAL / SOFT /HARD	A cleaning type is selected.

1 Press the **MODE CHANGE** key in LOCAL to select the printing mode.

```
<LOCAL . 1>      [ # 0 1 ]
                WIDTH : * * * * mm
```

2 Press the **FUNCTION** key.

```
FUNCTION
SETUP                <ENT>
```

3 Press the **ENTER** key.

```
SETUP
SELECT                : TYPE . 1
```

4 Press **▲ ▼** to select one of the types (1 to 4) and press the **ENTER** key.

5 Press **▲ ▼** to select [Print. CLEANING].

```
[ 1 ]
Print. CLEANING<ent>
```

6 Press the **ENTER** key.

```
[ 1 ]Print. CLEANING
SETUP                : OFF
```

7 Press **▲ ▼** to select ON.
• When selecting OFF, proceed to Step 10.

```
[ 1 ]Print. CLEANING
SETUP                : ON
```

8 Press the **FUNCTION** key.

```
INTERVAL : TYPE
1000mm   : NORMAL
```

9 Press **▲ ▼ ◀ ▶** to set a cleaning interval and a cleaning type.

Item selection : Select one with **◀ ▶**.

Setting of an interval and type:

Set an interval and type with **▲ ▼**.

```
TYPE : NORMAL
      SOFT
      HARD

INTERVAL:
10 to 10,000 mm

INTERVAL : TYPE
1000mm   : NORMAL
```

10 Press the **ENTER** key.

• Press the **END** key several times to end the setting.

Important!

- This function does not operate when ink near-end occurs. See P.1-14 "Changing an Ink Cartridge" to solve the ink near-end.
- Depending on the state of the heads, etc., the image quality deterioration may not be improved even with this function performed. In this case, contact our service office or the distributor in your region.

Other Settings

Change the settings according to the types of use.

1

Press the **MODE CHANGE** key in LOCAL to select the printing mode.

```
<LOCAL . 1>      [#01]
                WIDTH: *****mm
```

2

Press the **FUNCTION** key.

```
FUNCTION
SETUP          <ENT>
```

3

Press the **ENTER** key.

```
SETUP
SELECT        : TYPE . 1
```

4

Press **▲** **▼** to select one of the types (1 to 4) and press the **ENTER** key.

5

Press **▲** **▼** to select an item to set.

• See "List of Settings". (P.3-28)

6

Press the **ENTER** key.

7

Press **▲** **▼** to select a set value.

• See "List of Settings". (P.3-28)

8

Press the **ENTER** key.

9

Press the **END** key several times to end the setting.

Important!

• The set value is retained even when the power is turned "OFF".

P

3

Extended Functions – Printer –

List of Settings

The underlined has been set as default.

Function Name	Overview	Set Value
PINCH ROLLER	Setting the pinch roller pressure and the pinch roller numbers according to the medium to be used.	See P.3-5.
MEDIA COMP.	A medium-feeding rate is corrected.	See P.3-8.
DROP. POS CORRECT	Setting used when the thickness of the medium, head height, or ink type is changed.	See P.3-10.
HEATER	The heater temperature is set.	See P.3-12.
	The standby time and OFF time of the heaters are set.	
PRINT MODE	Printing quality is set.	See P.3-16.
	A scanning direction is set.	
	Logical seek is set.	
	White-laying printing is set.	
INK LAYER	The number of ink layers is set.	<u>Once</u> to nine times
DRYING TIME	Ink drying time for each scanning is set.	See P.3-21.
	Ink drying time after printing has been complete is set.	
AUTO CUT	Whether a medium is automatically cut after printing is set.	<u>ON/OFF</u>
PRE-FEED	Whether a medium is fed back and forth before printing is set.	<u>ON/OFF</u>
COLOR PATTERN	It is set whether a color pattern is printed on the right edge of a medium.*1	<u>ON/OFF</u>
REFRESH	The refreshing level of the heads is set.	<u>0</u> to 3
VACUUM	The ability to adsorb a medium is set.	<u>STORONG</u> / <u>STANDARD</u> / Little <u>WEAK</u> / <u>WEAK</u> / <u>OFF</u>
FEED SPEED	The speed at which a medium is fed during printing, etc. is set.	10 to <u>100</u> to 200%
PRIORITY	The prioritized setting (by the host or the panel) is determined.	<u>INDIVIDUALLY</u> / <u>ALL HOST</u> / <u>ALL PANEL</u>
AUTO CLEANING	Automatic head cleaning conducted for each printing operation is set.	See P.3-24.
PRINT. CLEANING	Automatic head cleaning conducted during printing is set.	See P.3-26.

*1. When ON is set, maximum printing width becomes 18mm narrower.

When cutting only with RasterLinkPro4SG or later, maximum cutting width also becomes 18mm narrower. If it affects the data layout, set to OFF.

Initializing the Settings

The already configured settings are initialized. (Resetting)
The setting items of the selected type are reset.

1 Press the **MODE CHANGE** key in LOCAL to select the printing mode.

```
<LOCAL . 1>      [#01]  
                WIDTH: ****mm
```

2 Press the **FUNCTION** key.

```
FUNCTION  
SETUP           <ENT>
```

3 Press the **ENTER** key.

```
SETUP  
SELECT         : TYPE . 1
```

4 Press **▲** **▼** to select one of the types (1 to 4) and press the **ENTER** key.

5 Press **▲** **▼** to select [SETUP RESET].

```
[ 1]  
SETUP RESET    <ent>
```

6 Press the **ENTER** key.

```
[ 1]SETUP RESET  
RESET         :ent
```

7 Press the **ENTER** key.
• The already configured settings are initialized.

8 Press the **END** key several times to end the resetting.



Machine Settings

Common settings are functions for using this machine easily.
The following items can be set in Machine settings.

Item		Set Value* ¹	Overview
DEODRIZE SETUP* ²	STOP TIME	OFF / 10 to <u>120</u> to 240 min/ CONTINUE	The time until the rotation of the exhaust fan stops after printing has been completed is set. (☞ P. 3-31)
	RENEW	ON/OFF	The present operating state of the exhaust fan is switched. (☞ P. 3-31)
DRYNESS FEED		ON/OFF	It is set whether a medium is fed for it to be dried after printing has been completed. (☞ P. 3-32)
STAMP SETUP		ON/OFF	The setting for the output date and printing conditions to be output after printing has been completed is configured. (☞ P. 3-33)
Waste Ink Warning		ON/OFF	It is set whether the confirmation message of the waste ink tank is displayed. (☞ P. 6-40)
Test PRT. Arrange		FEED DIR./ SCAN DIR.	The orientation of test patterns when test printing has been repeated is set. (☞ P. 3-34)
CART.PRIORITY * ³		INK LEVEL EXP. DATE	Setting a cartridge to be used first for double cartridge automatic change function.
ROOM. TEMP. * ⁴		<u>Not wait</u> ARR. Wait arrival	Sets the operation when an error indicating that the room temperature is out of the usable temperature range occurs. (☞ P. 3-35)

*1. The underlined has been set as default.

*2. The exhaust fan is optional.

*3. This function is valid only when the 4-color ink set is used.

*4. This function is available for the firmware Ver.2.30 and later.

Setting the DEODORIZE FAN

The exhaust fan operates during printing. After printing has been complete, it operates according to the setting of "Stop timer".

The following two items can be set for the exhaust fan.

- **STOP TIME** : The time until the exhaust fan stops after printing has been completed is set.
- **RENEW** : When this is set to "ON", the exhaust fan can operate while printing is not performed.

Important!

- The exhaust fan is an option contained in the drying exhaust unit.
- When this machine is equipped with a drying fan, the fan operates in cooperation with the settings configured here.

1

Press the **MODE CHANGE** key in LOCAL to select the printing mode.

<LOCAL . 1> [#01]
WIDTH : * * * * mm

2

Press the **FUNCTION** key.

FUNCTION
SETUP <ENT>

3

Press **▲ ▼** to select [MACHINE SETUP].

FUNCTION
MACHINE SETUP <ENT>

4

Press the **ENTER** key twice.

DEODRIZE FAN
STOP TIME <ent>

5

Press **▲ ▼** to select an item to set.

- STOP TIME** : The time until the exhaust fan stops after printing has been completed is set.
- RENEW** : Select this when you want to operate the exhaust fan.

6 Press the **ENTER** key.

7 Press **▲** **▼** to select a set value.

STOP TIME : 0 to 240 sec or continuous operation

RENEW : When you operate the exhaust fan, select "ON". When you stop the fan, select "OFF".

8 Press the **ENTER** key.

• Press the **END** key several times to end the setting.

Setting the DRYNESS FEED

It is set whether a medium is fed for it to be dried after printing has been completed.

1 Press the **MODE CHANGE** key in LOCAL to select the printing mode.

<LOCAL . 1> [#01]
WIDTH : * * * * mm

2 Press the **FUNCTION** key.

FUNCTION
SETUP <ENT>

3 Press **▲** **▼** to select [MACHINE SETUP].

FUNCTION
MACHINE SETUP <ENT>

4 Press the **ENTER** key.

MACHINE SETUP
DEODRIZE FAN <ent>

5 Press **▲** **▼** to select [DRYNESS FEED].

MACHINE SETUP
DRYNESS FEED <ent>

6 Press the **ENTER** key.

DRYNESS FEED
SETUP : **ON**

7 Press **▲** **▼** to select ON/OFF.

8 Press the **ENTER** key.

9 Press the **END** key several times to end the setting.

Stamp Setting

It is set whether information, such as printing conditions and a printing date, is output after printing has been completed.

- 1** Press the **MODE CHANGE** key in LOCAL to select the printing mode.

<LOCAL . 1> [#01]
WIDTH : * * * * mm
- 2** Press the **FUNCTION** key.

FUNCTION
SETUP <ENT>
- 3** Press **▲** **▼** to select [MACHINE SETUP].

FUNCTION
MACHINE SETUP <ENT>
- 4** Press the **ENTER** key.

MACHINE SETUP
DEODRIZE FAN <ent>
- 5** Press **▲** **▼** to select [STAMP SETUP].

MACHINE SETUP
STAMP SETUP <ent>
- 6** Press the **ENTER** key.

STAMP SETUP
STAMP : OFF
- 7** Press **▲** **▼** to select ON/OFF.
- 8** Press the **ENTER** key.

 - Press the **END** key several times to end the setting.

Output Example

```

CJV30-100 Ver1.00
PRINT MODE   : 540x1080 6PASS Uni-D Hi      1LAYER
MEDIA COMP.  : 100(-100,0,200)
HEAD GAP     : Thin
INK          : ES3INK 4color
HEATER TEMP.: PRE  :35°C PRINT:35°C POST :45°C
DATE        : 12.05.05 17:24:29
  
```

Setting the Test Print Arrange

The orientation of test patterns that are printed when test printing is repeated can be set.

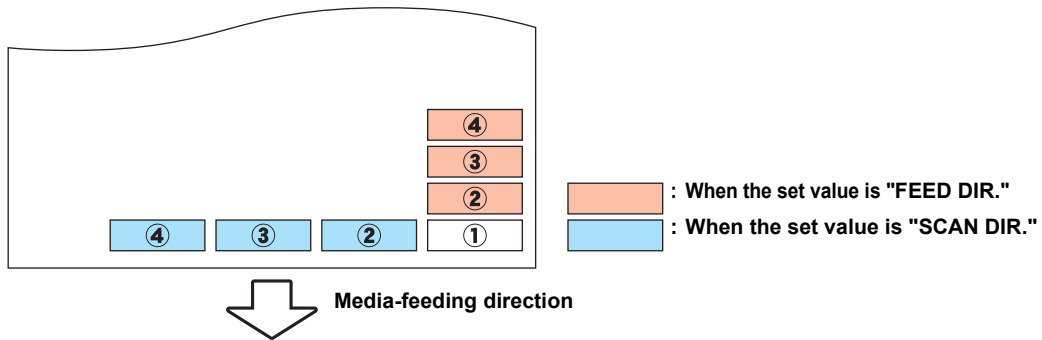

1

Press the **MODE CHANGE** key in LOCAL to select the printing mode.

```
<LOCAL . 1>      [#01]
                WIDTH: * * * * mm
```

2

Press the **FUNCTION** key.

```
FUNCTION
SETUP          <ENT>
```

3

Press **▲ ▼** to select [MACHINE SETUP].

```
FUNCTION
MACHINE SETUP <ENT>
```

4

Press the **ENTER** key.

```
MACHINE SETUP
DEODRIZE FAN  <ent>
```

5

Press **▲ ▼** to select [TestPRT.Arrange].

```
MACHINE SETUP
TestPRT.Arrange<ent>
```

6

Press the **ENTER** key.

```
TestPrintArrange
SETUP          : FEED DIR.
```

7

Press **▲ ▼** to select a set value.

FEED DIR. : Oriented in the media-feeding direction (rear) (default setting)
SCAN DIR. : Oriented in the media-scanning direction (lateral)

8

Press the **ENTER** key.

• Press the **END** key several times to end the setting.

Change the operation condition of the room temperature

If you print in the status that the temperature of the place in which the machine has installed (room temperature) is out of the usable temperature range, ink discharging defect or changing color may occur, and it adversely affects the printing quality.

Here, select the operation if the room temperature is out of the usable temperature range when printing.



- For the details of the usable temperature range, refer to P. 8-4 "Allowable temperature".
- If the room temperature is out of the usable temperature range at the start of printing, the error message below is displayed to inform you of it.

```
**** ERROR 120 ****
ROOM TEMP LOW (XX°C)
```

```
**** ERROR 121 ****
ROOM TEMP HIGH (XX°C)
```



- 1** Press the **(MODE CHANGE)** key in LOCAL to select the printing mode.

```
<LOCAL . 1>      [#01]
                WIDTH: ****mm
```
- 2** Press the **(FUNCTION)** key.

```
FUNCTION
SETUP          <ENT>
```
- 3** Press **(▲)** **(▼)** to select [MACHINE SETUP].

```
FUNCTION
MACHINE SETUP <ENT>
```
- 4** Press the **(ENTER)** key.

```
MACHINE SETUP
DEODRIZE FAN  <ent>
```
- 5** Press **(▲)** **(▼)** to select [ROOM TEMP.].

```
MACHINE SETUP
ROOM TEMP.    <ent>
```
- 6** Press the **(ENTER)** key.

```
ROOM TEMP.
SEL          :Not wait ARR.
```
- 7** Press **(▲)** **(▼)** to select a set value.

Not wait ARR. : The error message is displayed for a moment, and printing starts.
Wait arrival : After the error message is displayed, wait until the room temperature reaches the proper value. Then, printing starts.
- 8** Press the **(ENTER)** key.

 - Press the **(END)** key several times to end the setting.

Extension of Ink Expiry Month

Ink expiry month can be extended for six months from the expired month. When used without extension, ink becomes unusable after two months of the expiry month.

Extension of Ink Expiry Month

The following setting or confirmation screen appears when the power of this machine is turned on, or when expired ink cartridge is set.

Important!

- An ink cartridge that is once set [YES] for extension cannot be changed the setting.
- To extend multiple inks' expiry month at a time, set the expired ink cartridges, and then set the extension.
- Extension of ink expiry month may lower the print image quality or print quality such as color difference or banding. Please understand them when extending ink expiry month.
- When initial filling, the ink expired more than two months ago cannot be used.

1 When a screen shown on the right appears, go to the next step.

EXTEND EXPIRE DATE?
YES< >NO

alternately
displayed



NOT RECOMMENDED!!
YES< >NO

2 Press the to select [YES].

- When the ink expiry month is not extended, select [NO]. In this case, the ink will be disabled after two months of the expiry month.

EXPIRE DATE EXTENDED
PRESS [ENT]

3 Press the key.

- Ink expiry month is extended.



- When extended six months (six months from the ink expired month) have passed, a message "COMPLETELY EXPIRED" appears and the ink becomes unusable. Immediately replace the ink cartridge with a new one.
- If ink expiry month is extended, the cartridge LED blinks in green while supplying ink from the extended cartridge.

When a cartridge extended the expiry month is set

When a cartridge extended the expiry month is set and the power is turned on, or when a cartridge extended the expiry month is set to this machine, the following screen appears.

EXPIRED INK IN USE
PRESS [ENT]

alternately
displayed



NOT RECOMMENDED!!
PRESS [ENT]



Press the



- To check expired ink, press the key while displaying the screens above alternately.

When an ink expiry month is extended

Example: If expiry month of your ink cartridge is February 2014.

- When the expiry month is not extended

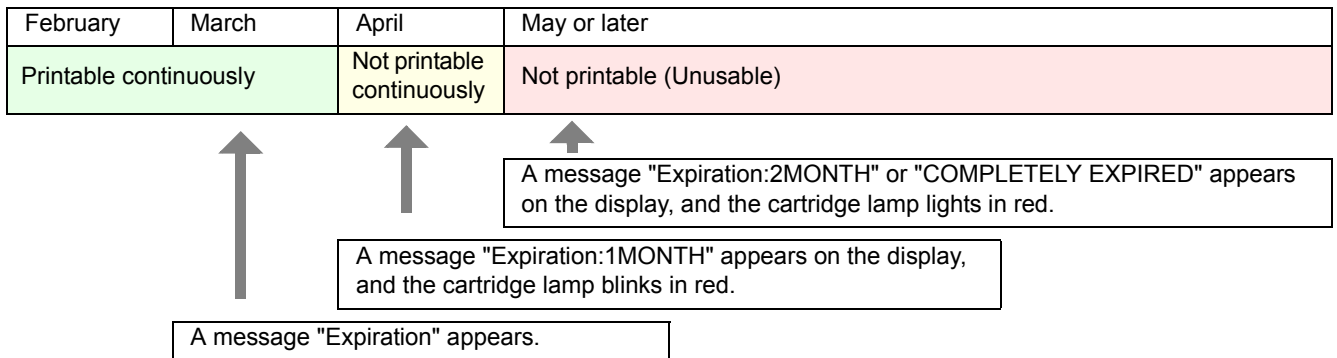

- When the expiry month is extended (When extended at the time of ▲)

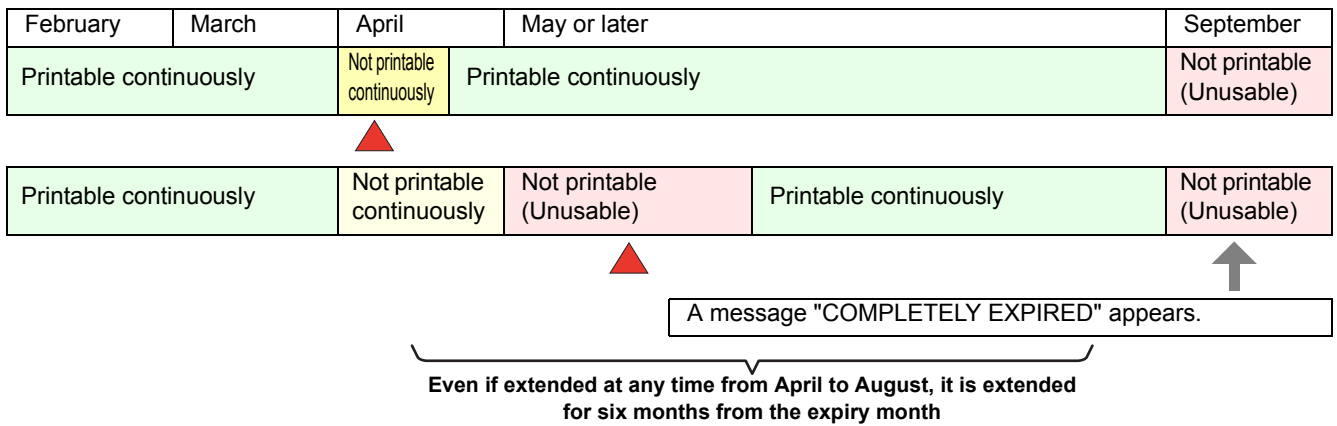

Switch Setting of Ink Supply Path

For the ink supply, condition of the ink cartridge to be used first by the double-cartridge automatic switching function can be selected.

This setting is only available for 4-color set.

Important!

- When expired ink cartridge is set, the expired cartridge is used first regardless of the setting below.
- When the optional bulk ink system (MBIS) is used and the MBIS is set in both slots, the setting below is effective.
- When both an ink cartridge and the bulk ink system (MBIS) are set in the supply paths of the same color, see the next page.

1

Press the **MODE CHANGE** key in LOCAL to select the printing mode.

<LOCAL . 1> [#01]
WIDTH : * * * * mm

2

Press the **FUNCTION** key.

FUNCTION
SETUP <ENT>

3



Select [MACHINE SETUP] by pressing the   keys.

FUNCTION
MACHINE SETUP <ENT>

4

Press the **ENTER** key.

5

Select [CART.PRIORITY] by pressing the   keys.

MACHINE SETUP
CART . PRIORITY <ent>

6

Press the **ENTER** key.

7

Select the condition of ink to be used first by pressing the   keys.

CART . PRIORITY
SELECT : INK LEVEL

INK LEVEL : Low ink cartridge is used first
EXP. DATE : Close-to-date ink cartridge is used first

8

Press the **ENTER** key.

9

Press the **END** key several times to end.



When both ink cartridge and MBIS are used

When both an ink cartridge and the optional bulk ink system (MBIS) are set in the supply paths of the same color for 4-color ink set, you can select the ink to be used first.



- Usually, when both an ink cartridge and the bulk ink system (MBIS) are set in the supply path of the same color, the ink in the bulk ink system (MBIS) is used first.

Important!

- This setting is only available for 4-color set.
- If supply path does not have both ink cartridge and the bulk ink system (MBIS), this function cannot be set.
- Pull out the ink cartridge selected on this function or turn the power on again to disable the setting.

1

Press the **ENTER** key in **LOCAL** or **REMOTE** of the printing mode.

ES3 - INK	MMCCYYKK
REMA I N	3 4 5 6 7 8 9 9

P

2

Press the **REMOTE** key.

BULK / CART SELECT
- B B B

Displays the currently supplying ink.
B : Bulk ink system (MBIS)
C : Ink cartridge
 - : Only one type is set

3

3

Press the **▲** **▼** **◀** **▶** key to set the supply path and the ink to be used first.

BULK / CART SELECT
- C B B

Select the supply path : Press the **◀** **▶** key.
 Select the ink to be used first : Press the **▲** **▼** key.

4

Press the **ENTER** key.

- It enters in the LOCAL or the REMOTE mode.

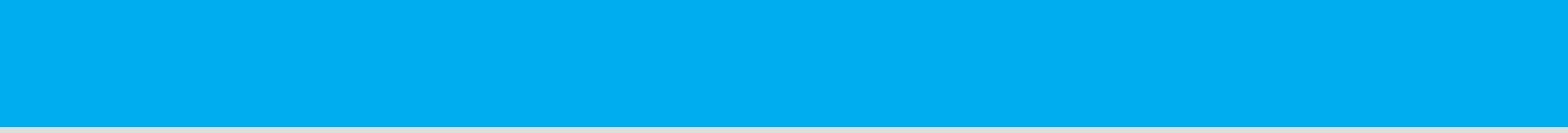

Chapter 4

Extended Functions – Cutting –



This chapter

describes the operation procedures for using the cutting function more conveniently and each setting procedure.

Setting the Pinch Rollers	4-2	Changing the Order of Cutting	4-28
Recommended Setting for the Pinch Roller		Setting the SORTING	4-29
Pressure and Number of Pinch Rollers	4-2	Procedure for SORTING	4-31
Quantity of Pinch Rollers	4-2	Cutting out Data without Register Marks	4-32
Setting for the Pinch Rollers	4-3	Setting the P/C ORIGIN OFFSET	4-32
Cutting out Data with Register Marks	4-5	Setting the P/C SCALE ADJUST	4-34
Flow of Cutting Data with Register Marks ...	4-5	Other Settings	4-36
Entering Register Mark Detection Mode	4-5	Copying the Setting Contents	4-40
Notes on Inputting Data with Register		Initializing the Settings	4-41
Marks	4-6	Cutting Samples	4-42
Setting Register Mark Detection	4-11	Cutting a Medium into Multiple Pieces	
Method of Detecting Register Marks	4-15	with a Certain Length	4-44
When Cutting Failed	4-17	Perform Multiple Cuttings	4-46
Setting Automatic Cutting	4-22	Setting the Step Size	4-48
Dividing and Cutting	4-23	Other Convenient Functions	4-49
Setting the Dividing and Cutting Function .	4-23	Medium Feeding	4-49
Cutting Data by Using the Dividing and		How to turn the heater OFF in the cutting	
Cutting Function	4-25	mode	4-50
Cutting with a Dotted Line	4-26		

Setting the Pinch Rollers

Set the pinch roller pressure and the pinch roller numbers according to the medium to be used.

Settings	Set Value	Overview
ENDS	HIGH	Set the pressure for the pinch rollers at both ends of the medium according to the medium to be used.
	MIDDLE	
	LOW	
INNER	HIGH	Set the pressure for the pinch rollers other than those at both ends of the medium according to usage.
	MIDDLE	
	LOW	
	OFF	
No.	2 to 7 *1	Set the number of the leftmost pinch roller according to the size of the medium to be used.

*1. The number of pinch rollers varies according to the machine type.

Recommended Setting for the Pinch Roller Pressure and Number of Pinch Rollers

The table below shows the recommended pinch roller pressure for cutting:

Set pressure	Usage
ENDS: High INNER: High	For standard operation
ENDS: High INNER: Low	Use this combination of settings when you want the streaks made by the pinch rollers on the medium to be unnoticeable. <ul style="list-style-type: none"> This setting may cause misalignment of the medium depending on the medium type, feeding rate, or medium width.

Medium width	Required pinch rollers
Less than 600 mm	Both ends only
600 to 1,300 mm	Both ends + 1 middle pinch roller
1,300 mm or more	Both ends + 2 middle pinch rollers

Important!

- When you use the machine under conditions other than the above, the medium may slip out of place during cutting.
- Adjust the pinch roller pressure according to the situation.

Quantity of Pinch Rollers

The following table shows the quantity of pinch rollers for each model. Check the pinch rollers on your machine for quantity.

Model	Quantity
CJV30-160	7 pieces
CJV30-130	6 pieces
CJV30-100	4 pieces
CJV30-60	3 pieces

Setting for the Pinch Rollers

This section describes the setting procedure for CJV30-160.
 For CJV30-130/100/60, the number of pinch rollers set in Step 10 varies.

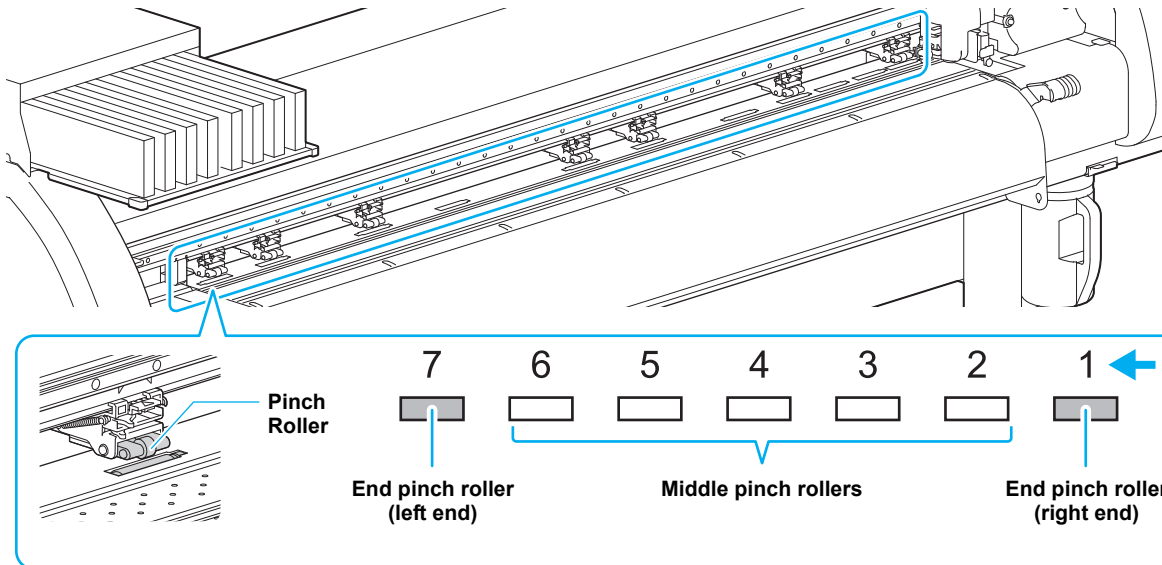

• The figure above shows CJV30-160.



4

- 1** Press the **MODE CHANGE** key in LOCAL to select cutting mode.

<LOCAL . **C**> [#01]
 CUT1 (30 / 60 / 0.30)
- 2** Press the **FUNCTION** key.

FUNCTION
 SETUP <ENT> **C**
- 3** Press the **ENTER** key.

SETUP
 SELECT : CUT1
- 4** Press **▼** **▲** to select a tool condition (CUT1 to CUT3, HALF, PEN) and press the **ENTER** key.
- 5** Press the **ENTER** key twice.



ENDS : **H**IGH [H ___ H]
 INNER : OFF No . 7 - 1
- 6** Press **▲** **▼** to set the pressure for the pinch rollers at both ends of the medium.

ENDS : **M**ID. [H ___ H]
 INNER : OFF No . 7 - 1

• Set value: HIGH/MID./LOW
- 7** Press **▶** to move the cursor to the middle pinch roller setting.

ENDS : MID. [H ___ H]
 INNER : **O**FF No . 7 - 1

8

Press   to set the pressure for the middle pinch rollers.

• Set value: HIGH/MID./LOW/OFF



ENDS : MID. [H___H]
INNER: MID. No. 7-1

9

Press  to move the cursor to the pinch roller number setting.

ENDS : MID. [H___H]
INNER: MID. No. **7**-1

10

Press   to set the number of the pinch roller at the left end of the medium.

• Set value: 2 to 7

ENDS : MID. [___H___H]
INNER: MID. No. **4**-1

11

Press the  key.

12

Press the  key several times to end the setting.

Important!

- The pinch roller pressure set here is reflected to the medium under the following conditions:
When performing print/cut remotely
When detecting the medium next
- If you want to reflect the set value to the current medium, move the clamp lever up and down to detect the medium again.

Advanced Setting for the Middle Pinch Rollers

Advanced setting is available for the middle pinch rollers.

1



Perform the operations in Steps 1 to 10 in P. 4-3 "Setting for the Pinch Rollers".

2

Press the  key.

ENDS : MID. [H___H]
INNER: MID. No. **3**-1

3

Press   to select a pinch roller to set, and press   to set the advanced setting.

ENDS : MID. [H___**L**___H]
INNER: MID. No. **3**-1

4

Press the  key.

5

Press the  key several times to end the setting.

Cutting out Data with Register Marks

If you create register marks on an output image, the cutter unit detects these marks and cuts the image out automatically following these marks. This helps you to make stickers, etc.

This section describes how to cut the printed medium.

Refer to P.4-10 for the combined operation of print & cut.

There are following two types of register marks.

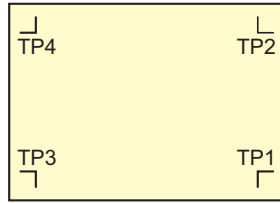

Register mark: Type 1

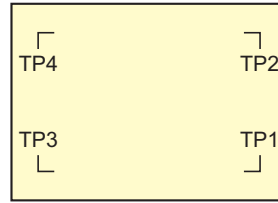

Register mark: Type 2



- Use the TP4 when performing trapezium correction to correct the uneven medium-feeding rate caused by the difference in the diameter between the right and left grid rollers. If the trapezium correction is to be omitted, there is no need to set the TP4. In that case, however, cutting distortion will increase.

Flow of Cutting Data with Register Marks

Add register marks on the image with which you want to make a sticker, etc., and then print the image with register marks on a medium.

There are some conditions for creating the register marks.
See pages P.4-6 through P.4-10.

Set the printed medium in CJV30.

Set it referring to P.2-15.

Send the cut-target image from the computer for cutting.

In case it is not successfully cut,
• Confirm the response of the register mark sensor. (☞ P.4-17)
• Confirm the position of the Light Pointer. (☞ P.4-20)
• Adjust the sensitivity of the register mark sensor. (☞ P.4-21)

Entering Register Mark Detection Mode

1

Press the **END** key in LOCAL.

- The machine enters the register mark detection mode.



- When the registration detection is set to OFF, the machine doesn't enter registration mode. (☞ P.4-11)
- If this key is pressed while various settings are being configured, the input value may be canceled or the active set item may be returned to the previous set item.



4

Extended Functions – Cutting –

Notes on Inputting Data with Register Marks

There are some limitations on preparing data with register marks.

In order to make full use of this function, read the following instructions carefully and prepare data with register marks properly.

Important!

- The register mark described here is intended to detect the medium skew and the lengths along the X and Y axis. It is not a mark for trimming.

Size of the Register Marks

Refer to "The Size of a Register Mark Suited for the Distance between the Marks" (P.4-8) for the relationship between the data and the length of one side of a register mark.

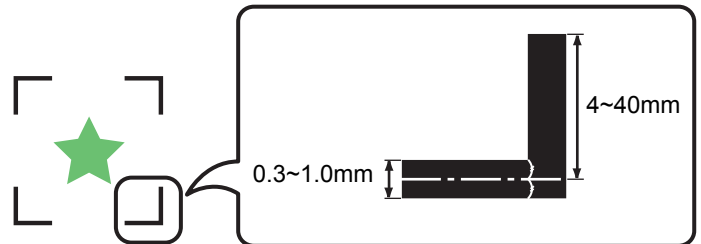

The Area Where Register Marks and Designs Can Be Arranged

- The TP1 starting position must be at least 20 mm away from the front end of the medium.
- The TP2 end position must be at least 30 mm away from the rear end of the medium.

Register mark: Type 1

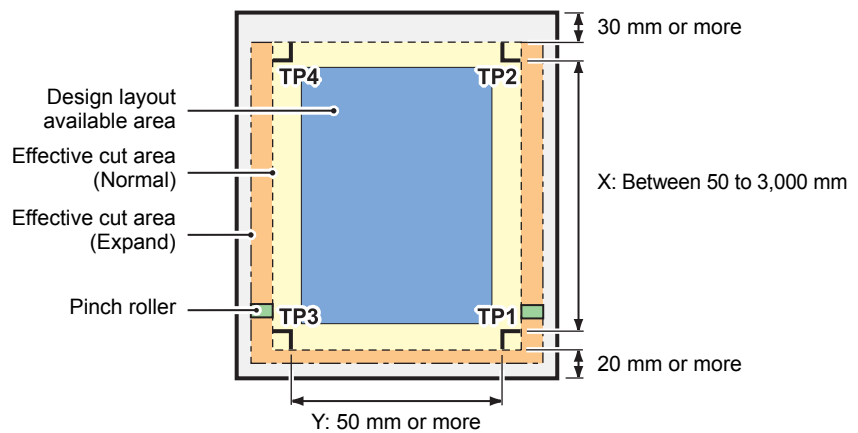

Register mark: Type 2

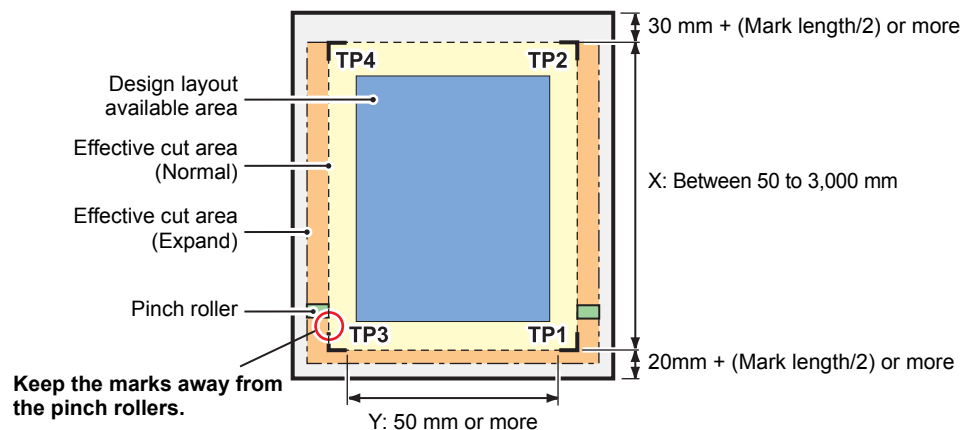

No-printing Area around the Register Marks

An area around a register mark (from the mark origin to the mark size area) is a non-printing area. There must be no data printed or stain in this area. Otherwise, a wrong origin may be detected or a mark read error can occur.

Important!

- If a wrong mark origin is detected, the cutting will be performed in the wrong area.

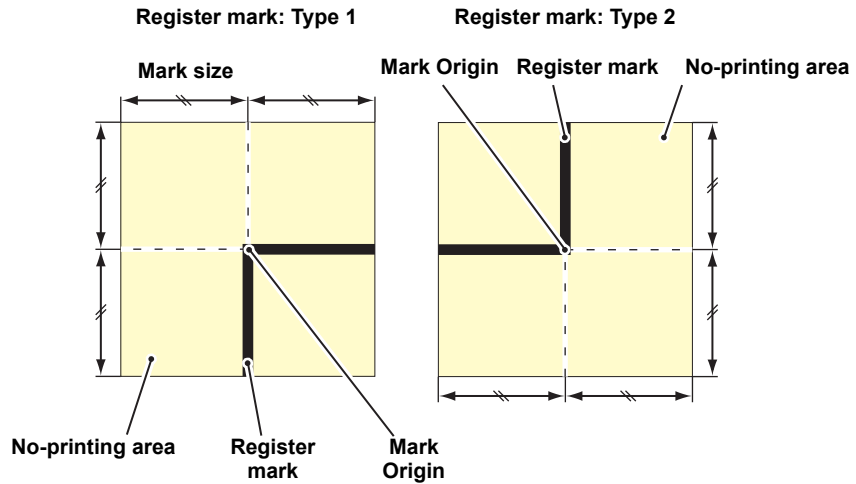

Example of Cause of Wrong Detection 1

There is a line outside the register marks

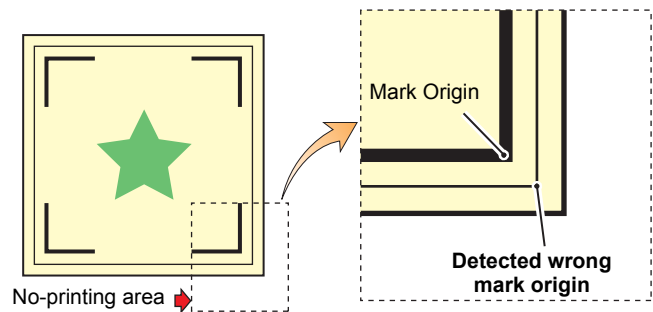

Example of Cause of Wrong Detection 2

The distance between register marks (TP2 and TP1 or TP4 and TP2) is smaller than the mark length (for Type 2)

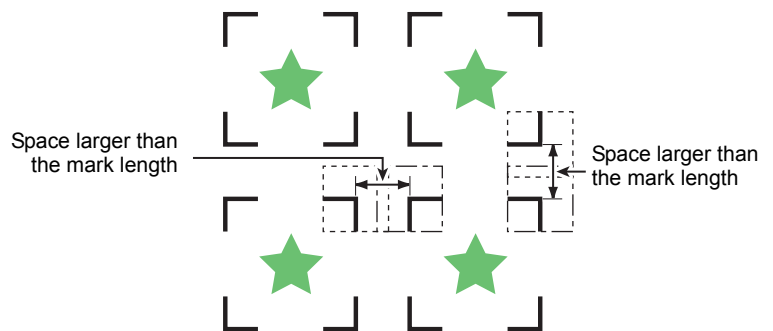

The Size of a Register Mark Suited for the Distance between the Marks

The size (B) of a register mark suited for the distance (A) between the marks is as shown below. If the mark size (B) is too small relative to the distance (A), the marks may not be detected correctly. Be sure to prepare the register marks with an appropriate size.

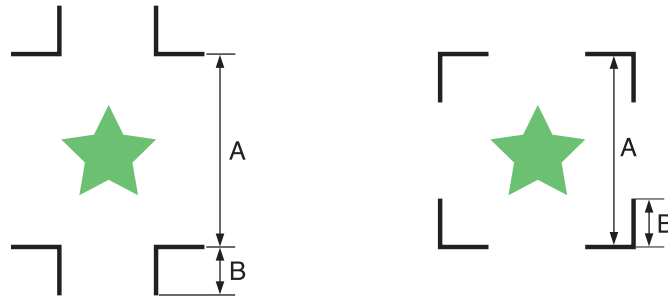

A	200 or less	500	1000	2000	3,000 or more
B	4 ~	8 ~	15 ~	25 ~	35 ~

(mm)

Distance between Register Marks for Copied Designs

For Type 1 register marks, the distance between the marks must be not shorter than two times the mark length and not longer than 1,000 mm. For Type 2 register marks, the distance between the marks must be not shorter than the mark length and not longer than 1,000 mm.

Register mark: Type

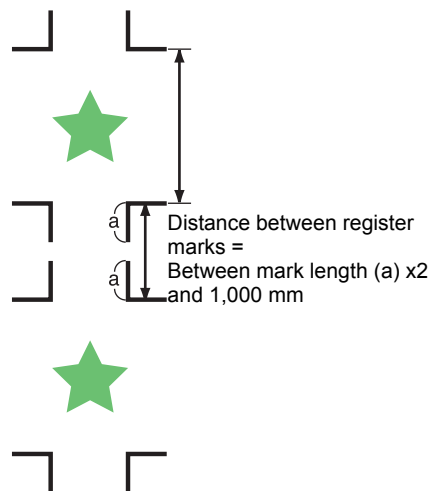

Register mark: Type 2

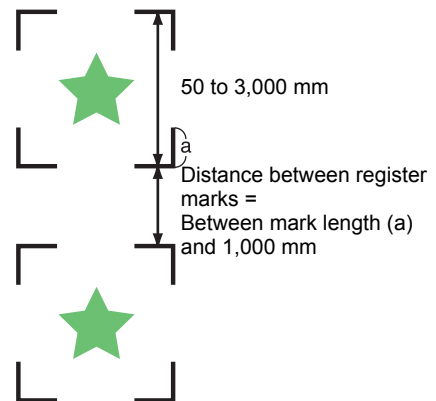

The Recommended Size of the Area Defined with a Set of Four Register Marks

It is recommended that the size of the area defined with a set of four register marks is in the range of A4 size (210 mm x 297 mm) to A3 size (297 mm x 420 mm).

If you follow this recommendation, you can minimize wasteful spaces and arrange the designs efficiently.

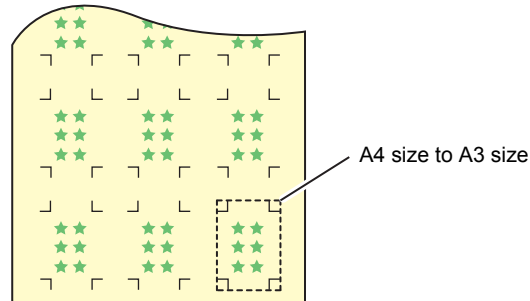

Color of Mark

The mark must be printed in black against the white background.

The register mark will not be detected correctly if the background is not white or the mark is not black.

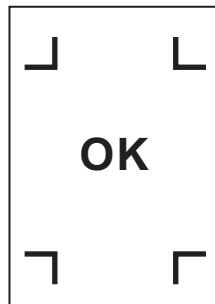

Mark Blurred

If the mark is blurred, a wrong mark origin can be detected, thus resulting in deviated cutting.



4

Extended Functions – Cutting –

Notes on Register Mark Detection

Observe the following precautions on register mark detection.

- When you retry medium detection, medium skew correction, scale correction between register marks, and the position of the origin are cleared.
- Once the cutter unit detects marks, it will set the origin at the location of TP1.
If you change the position of the origin to a different location using the jog keys, the origin at the new location will supersede the origin at TP1.
- Locate register marks so that the line connecting the corners of the four marks forms a rectangle.
Register marks arranged unevenly can result in deviated cutting.

Notes for the combined operation of print & cut

When performing combined operation of print & cut with Raster Link Pro 4 SG or later, be careful to the following items:

(1) When performing combined operation of print & cut with the attached application software to this device (Raster Link Pro 4 SG or later / FineCut 7.0 or later /), the following set contents will follow the instruction of software side. Note that the contents set in this device will be invalid.

- Register mark size
- Register mark shape
- The number of sheets

(2) The combined operation of print & cut without a register mark is not performed under the following conditions:

- Print & cut using the take-up device
- Print & cut when "COLOR PATTERN ( P.3-28) " of the setting mode is set to "ON"



- Other than the above conditions, there is a possibility of the cutting line being misaligned depending on the printing data size. Therefore, it is also recommended to perform the operation with the data which has register marks for combined operation of print & cut.

Setting Register Mark Detection

When you want to cut the data with register marks, set the following without fail.

- 1** Press the **MODE CHANGE** key in LOCAL to select cutting mode.

```
<LOCAL .C>      [#01]
CUT1 ( 30 / 60 / 0.30 )
```
- 2** Press the **FUNCTION** key.

```
FUNCTION
SETUP      C
<ENT>
```
- 3** Press the **ENTER** key.

```
SETUP
SELECT      : CUT1
```
- 4** Press **▼** **▲** to select a tool condition (CUT1 to CUT3, HALF, PEN) and press the **ENTER** key.
- 5** Press **▼** **▲** to select [MARK DETECT].

```
[ CUT1 ]
MARK DETECT  <ent>
```
- 6** Press the **ENTER** key.

```
[ CUT1 ] MARK DETECT
DETECT      : OFF
```
- 7** Press **▼** **▲** to select number of detected register marks.
 • Set values: OFF, 1pt, 2ptX, 2ptY, 3pt, 4pt
- 8** Press the **ENTER** key.
 • In case you selected "OFF" in Step 7, proceed to Step 12.
- 9** Press **▼** **▲** to select the following items, and then press the **ENTER** key.

 - The following items are provided for the register mark detection setting.
 Mark detect, Register mark size, offset Y, offset X, form of register mark, number of continuous cutting in direction Y, number of continuous cutting in direction X, high speed limi, and skew check
 - See pages P.4-12 through P.4-14 for details of each set item.
- 10** Press **▼** **▲** to select a set value.
 • See pages P.4-12 through P.4-14 for set values for each set item.
- 11** Press the **ENTER** key to enter the value.
- 12** Press the **END** key several times to return to LOCAL.



4

Set Items

MARK DETECT

The higher the number of detected points, the higher the cutting accuracy.
Select "1pt" when using Raster Link Pro4 SG (or later) or FineCut.

Set Value	Description
OFF	Select this setting for cutting a normal medium, not for cutting the outline.
1pt	Detects the TP1. Sets only the origin.
2pt X	Detects the two register marks TP1 and TP2 (Feeding direction). Performs the skew correction and the scale correction in the medium feeding direction.
2pt Y	Detects the two register marks TP1 and TP3 (Width direction). Performs the skew correction and the scale correction in the width direction.
3pt	Detects the three register marks TP1, TP2 and TP3. Performs the skew correction and the scale correction in the medium feeding and the width direction.
4pt	Detects the four register marks TP1, TP2, TP3 and TP4. Performs the skew correction, the scale correction in both directions, and the trapezium correction.

MARK SIZE

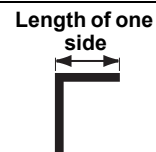

Set Value	Description
4 to 40 mm	Set the length of one side of the register mark. When the horizontal and vertical lengths of the printed mark differ from each other, set the same value as the shorter length.



OFFSET Y / OFFSET X

Set Value	Description
± 40.00 mm	<p>Generally the origin will be set at the position shown below. However, the position information of the origin may differ depending on the application software. In this case, the location of the origin can be corrected.</p> <div style="display: flex; justify-content: space-around; align-items: center;"> <div style="text-align: center;"> <p>Register mark: Type 1</p> <p>The diagram shows an L-shaped register mark with a red dot at the top-left corner. A blue arrow points right from the dot, labeled "Plus X direction". A blue arrow points down from the dot, labeled "Plus Y direction". A blue arrow points up from the bottom-right corner of the L, labeled "Origin".</p> </div> <div style="text-align: center;"> <p>Register mark: Type 2</p> <p>The diagram shows an L-shaped register mark with a red dot at the bottom-right corner. A blue arrow points right from the dot, labeled "Plus X direction". A blue arrow points down from the dot, labeled "Plus Y direction". A blue arrow points up from the top-left corner of the L, labeled "Origin".</p> </div> </div> <p>If the origin is located out of the available cutting area, "ERR37 MARK ORG" will be displayed. In this case, write the register marks in the area closer to the center of the sheet.</p>

MARK TYPE

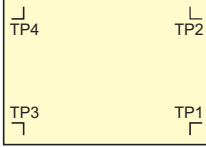
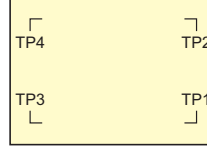
Set Value	Description
TYPE1  TYPE2 	<p>Select either one of the following types of register marks.</p> <p style="text-align: center;">MARK : TYPE 1</p> <div style="display: flex; justify-content: space-around;"> <div style="border: 1px solid black; padding: 5px; text-align: center;">  </div> <div style="border: 1px solid black; padding: 5px; text-align: center;"> <p>MARK : TYPE 2</p>  </div> </div>

COPIES (X) / COPIES (Y)

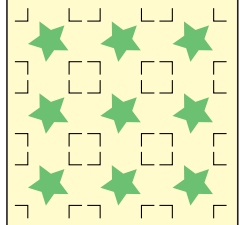
Set Value	Description
1 to 9999 (COPIES X) 1 to 99 (COPIES Y)	<p>Effective when the same pattern is multi-printed at regular intervals. Cuts automatically the preset number of sheets while detecting register marks consecutively based on the first data.</p> <div style="display: flex; align-items: flex-start;"> <div style="border: 1px solid black; padding: 5px; margin-right: 20px;">  </div> <div> <p>For leaf sheets (cut sheets), the value of [COPIES Y] is used as the number of copies. When the number of copies can be set on the application software, like on the supplied FineCut, set the value to [1].</p> </div> </div>

SPEED LIMIT

Set Value	Description
0 to 30 cm/s	<p>Set a speed limit for rapid moving in continuous copying. During rapid moving, mark detection may not be performed correctly if a slippery medium is used. In such a case, set a speed limit. If no speed limit is required, set the value to "0".</p>



4

Setting of skew check

Set Value	Description
0 to 99 mm	<p>This will set the allowable value of sheet declination when copying continuously. When copying continuously for roll sheet, the printing position may be misaligned gradually because of the sheet declination etc. In such a case, the operation can be continued by detecting register marks again with the following procedures:</p> <p>If the coordinate value of B axis of the Register mark 1 is misaligned exceeding the setting value, cutting operation suspends. When pressing the ENTER key, the device enters the register mark detection waiting mode. To restart the register mark detection, move the light spot of the light pointer to the position described in the figure below with the jog key and press the ENTER key. At this time, do not correct the medium by raising the clamp lever. The operation cannot be continued. If check is not performed, set "0".</p> <div style="text-align: center;"> <p>MARK : TYPE 1 MARK : TYPE 2</p> <p>Reference mark 1 Reference mark 2</p> <p>(TP1) (TP1)</p> <p>Position of starting register mark detection</p> </div>

Resetting the Setting of Register Mark Detection

In case the cutter unit detects a medium that has no printing of register marks and displays [SEARCH START POS.], set the register mark detection to "OFF". Then, the register mark detection is disabled.

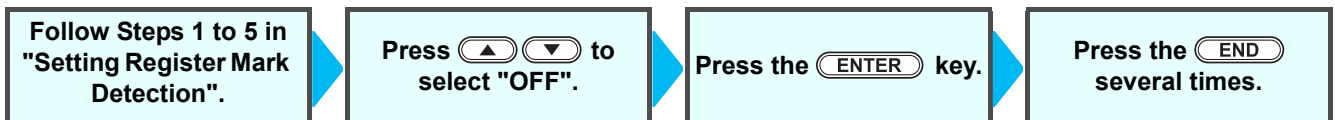

Method of Detecting Register Marks

Important!

- If the medium is curled, straighten it.
When using a cutting software having no mark function, use a medium which has neither stains nor images in the area (A) located between TP1 and TP2 and in the area (B) located between TP1 and TP3.

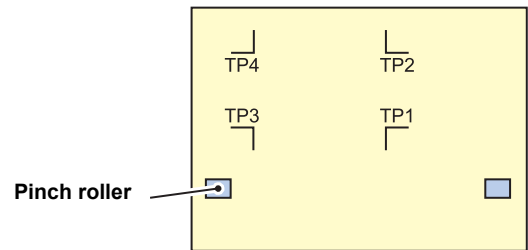

Setting the Origin of the Register Mark Right after Setting of a Medium

Important!

- Set the setting of the register mark detection to [1pt] or more in advance. (☞ P.4-11)

1

Load the medium and lower the clamp lever.

- The pinch rollers retain the sheet.
- Set the medium referring to the procedures from P.2-25.

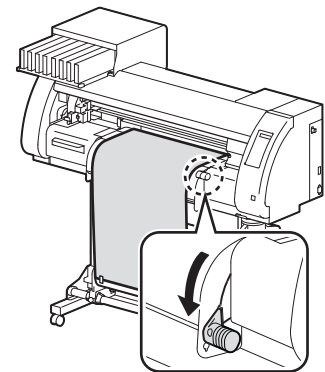

2

Detecting the medium

- Detect the medium referring to P.2-25 "Setting a Roll Medium".
- Once the sheet is detected, the display indicates that the cutter unit is waiting for the register mark detection operation.

SEARCH START POS.
0.0 0.0

3

Move the Light Pointer into the area shown below by pressing .

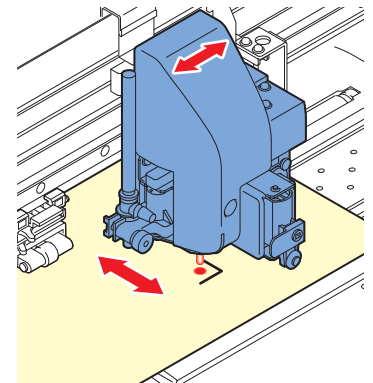
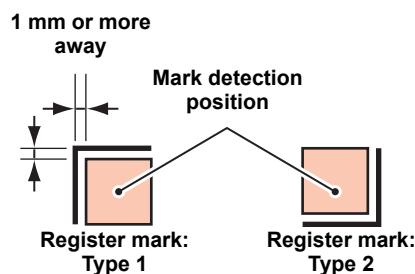

4

Extended Functions – Cutting –

4

Press the **ENTER** key after completing the settings.

- The plotter will start detecting the register marks according to the settings of [MARK DETECT].
 - See "MARK DETECT" (🔧 P.4-12) for the number of register marks.
 - In case the cutter unit cannot detect any register marks, it displays "ERROR36 MARK DETECT" on the display. Set the medium again.
-

5

Set the origin.

- The display will show the available cutting area and then return to LOCAL.
-

Setting the Origin of the Register Mark after Test Cutting

 Important!

- Set the setting of the register mark detection to [1pt] or more in advance. (🔧 P.4-11)
-

1

Confirm the cutting mode is local, press **END** key.

- Light pointer will be lit.
- If the mode is printer mode, press the **MODE CHANGE** key to switch.

<LOCAL .  >	[#01]
CUT1 (30 / 60 / 0.30)	

2

Set the origin by performing the procedure 3 of P.4-15 "Setting the Origin of the Register Mark Right after Setting of a Medium".

When Cutting Failed

Checking the Sensor for the Register Mark Detection

Important!

- You cannot check the response correctly by moving the head or medium manually. Be sure to follow the steps below to check the response.
- For conditions of an already printed register mark, refer to "Notes on Inputting Data with Register Marks" (☞ P.4-6).
- The setting values are kept in memory even when the power is turned OFF.
- The settings performed here for type and length of the register mark are reflected in the settings of "Setting Register Mark Detection" (☞ P.4-11).
- The detection speed selected here will be used in the register mark detection operations thereafter.
- The pointer offset value and sensor gain setting value selected by this operation are not initialized by "Initializing the Settings" (☞ P.4-41).

1

Press the **MODE CHANGE** key in LOCAL to select cutting mode.

```
<LOCAL .C> [ #01 ]
CUT1 ( 30 / 60 / 0.30 )
```

2

Press the **FUNCTION** key.

```
FUNCTION
SETUP <ENT>
```

3

Press **▼ ▲** to select [MAINTENANCE].

```
FUNCTION
MAINTENANCE <ENT>
```

4

Press the **ENTER** key twice.

```
MARK SENSOR
SENSOR CHECK <ent>
```

5

Press the **ENTER** key.

- Light pointer will be lit.

```
MARK SENSOR
SIZE = 10mm
```

6

Press **▼ ▲ ◀ ▶** to move the light pointer to the register mark detection position.

- The register mark detection position should be at least 1 mm away from a register mark.

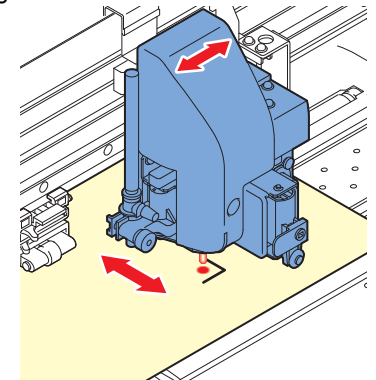
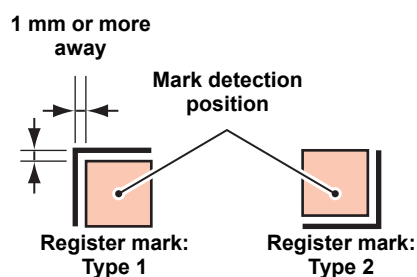

Important!

- The origin set here is registered as the origin for normal printing/cutting. If changing the origin after completion of confirming the register mark sensor, perform the operation in P.2-33 "When Changing the Origin".



4

7

Press the **ENTER** key.

MARK SENSOR SIZE	= 10mm
---------------------	--------

8

Press **▼** **▲** to set the size of the register mark, and then press the **ENTER** key.

MARK SENSOR FORM	: TYPE1 $\frac{+}{-}$
---------------------	-----------------------

- Set value: 4 to 40 mm
- The value entered here is reflected in the "MARK DETECT".

9

Press **▼** **▲** to select the type of the register mark, and then press the **ENTER** key.

MARK SENSOR SPEED	= 10 cm/s
----------------------	-----------

- Set value: TYPE 1($\frac{+}{-}$), TYPE 2(\square)
- The value entered here is reflected in the "MARK DETECT".

10

Press **▼** **▲** to set the register mark reading speed, and then press the **ENTER** key.

- Set value: 10 to 20 cm/s
- The value entered here is reflected in the "MARK DETECT".

11

Press **▶** to execute the register mark detection. (see the next page)



Detect Operation

1 Scan in the X direction (plus direction) to confirm that the line can be detected.

- The buzzer sounds when the line is detected. If the line is not detected, the buzzer does not sound.

2 Scan in the X direction (minus direction) to confirm that the line can be detected.

3 Scan in the Y direction (plus direction) to confirm that the line can be detected.

4 Scan in the Y direction (minus direction) to confirm that the line can be detected.

5 Confirm that the buzzer sounds 4 times upon completion of Steps 1 to 4.

- When the detection behavior completes successfully, the buzzer sounds 4 times.
- If the cutter unit failed to detect the line, perform "Adjust the Sensitivity (Light Intensity) of the Mark Sensor LED (Automatically)" (P.4-21).
- If the cutter unit cannot detect the line successfully even after you adjusted the sensitivity, verify the registration conditions and contact our service office.

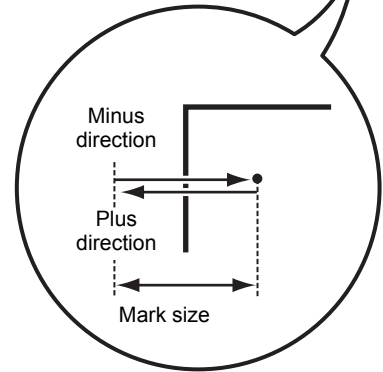
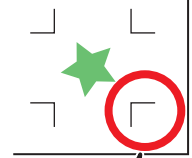

Scan in the Y direction

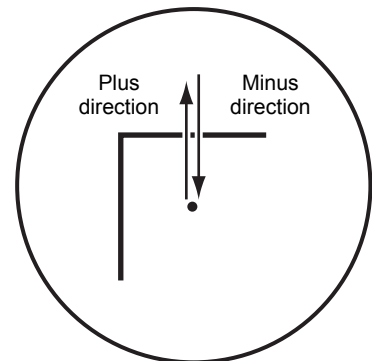

Scan in the X direction



4

Correcting the Light Pointer Position

If the cutter unit fails to recognize any register mark properly, the possible cause is an error in the positional relationship between the mark sensor and the light pointer. In this case, correct the position of the light pointer.

1 Install a water-based ballpoint pen in the tool holder.

- When making an adjustment, use a special pen for the cutter unit to reduce the fudge factor. Any pen color works for the adjustment. You can order the special pen from the distributor in your region.

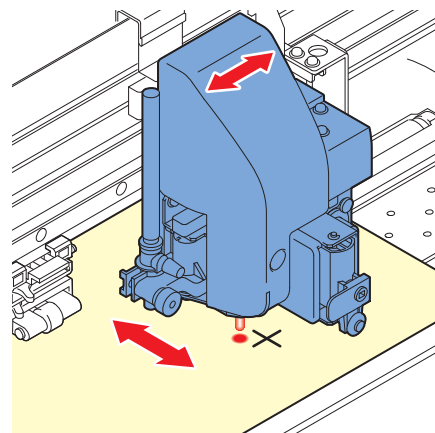

2 Make sure that the machine is in cutting mode.

- If the machine is in printer mode, press the **MODE CHANGE** key to switch the mode to cutting mode.

```
<LOCAL .C> [ #01 ]
CUT1 ( 30 / 60 / 0.30 )
```

3 Press the **FUNCTION** key.

```
FUNCTION
SETUP <ENT>
```

4 Press **▼ ▲** to select [MAINTENANCE].

```
FUNCTION
MAINTENANCE <ENT>
```

5 Press the **ENTER** key twice.

```
MARK SENSOR
SENSOR CHECK <ent>
```

6 Press **▼ ▲** to select [POINTER OFFSET].

```
MARK SENSOR
POINTER OFFSET <ent>
```

7 Press the **ENTER** key.

- A 10 mm by 10 mm cross pattern will be plotted with a pen.
- The light pointer turns on and moves to the center of the cross pattern.

8 Press **▼ ▲ ◀ ▶** to adjust the light pointer position so that the center of the light pointer is in alignment with the center of the cross pattern.

9 Press the **ENTER** key.

- The machine will return the screen in Step 1 after registering the correction value.

```
POINTER OFFSET
Y = 0.3 X = 0.5
```

Important!

- The value registered in the [POINTER OFFSET] is not initialized even by executing P.4-41 "Initializing the Settings".

Adjust the Sensitivity (Light Intensity) of the Mark Sensor LED (Automatically)

If an error occurs frequently in register mark detection, a possible cause is an improper sensitivity of the mark sensor LED. In this case, adjust the sensitivity (light intensity) of the mark sensor LED.

Important!

- Make sure that the medium is clean and white, and locate the medium directly under the sensor.

1

Make sure that the machine is in cutting mode.

- If the machine is in printer mode, press the **MODE CHANGE** key to switch the mode to cutting mode.

```
<LOCAL . [C]>      [#01]
CUT1 ( 30 / 60 / 0.30)
```

2

Confirm that the mark sensor is located just above a plain area (non-printed area) of the medium.

- If the mark sensor is not located just above a plain area, correct the location by pressing **▲ ▼ ◀ ▶**.

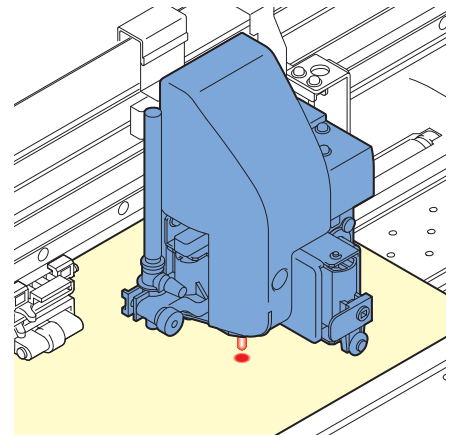

3

Press the **FUNCTION** key.

```
FUNCTION          [C]
SETUP             <ENT>
```

4

Press **▼ ▲** to select [MAINTENANCE].

```
FUNCTION          [C]
MAINTENANCE      <ENT>
```

5

Press the **ENTER** key twice.

```
MARK SENSOR
SENSOR CHECK     <ent>
```

6

Select [LEVEL ADJUST] by pressing **▼ ▲**.

```
MARK SENSOR
LEVEL ADJUST     <ent>
```

7

Press the **ENTER** key.

```
LEVEL ADJUST
OUT: ****  IN: ****
```

8

Press the **ENTER key after the number displayed on the screen is stabilized.**

- If all digits of the number cannot be stabilized, press the **ENTER** key when the leftmost digit of the number is fixed.
- The adjusted value is registered and the machine returns to LOCAL.
- Pressing the **FUNCTION** key enables you to move the cutter unit manually.

Important!

- The value registered in [LEVEL ADJUST] will not be initialized even if the procedure described in P.4-41 "Initializing the Settings" is performed.



4

Extended Functions – Cutting –

Setting Automatic Cutting

A medium is automatically cut off after cutting has been complete.

1 Press the **MODE CHANGE** key in LOCAL to select the cutting mode.

```
<LOCAL . C>      [#01]
CUT1 ( 30 / 60 / 0.30)
```

2 Press the **FUNCTION** key.

```
FUNCTION
SETUP          <ENT> C
```

3 Press the **ENTER** key.

```
SETUP
SELECT          : CUT1
```

4 Press **▼** **▲** to select one from the tool conditions (CUT1 to CUT3, PEN, and HALF) and press the **ENTER** key.

5 Press **▼** **▲** to select [AUTO CUT].

```
[ CUT1 ]
AUTO CUT      <ent>
```

6 Press the **ENTER** key.

```
[ CUT1 ] AUTO CUT
SETUP          : OFF
```

7 Press **▼** **▲** to select "ON" and press the **ENTER** key.

```
[ CUT1 ] AUTO CUT
CUT MARGIN    : 00mm
```

• When you do not want to set AUTO CUT, select "OFF" and proceed to Step 10.

8 Press **▼** **▲** to select a margin length (0 to 30 mm) and press the **ENTER** key.

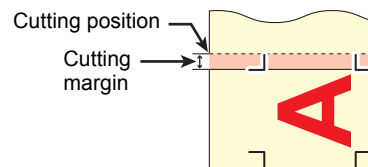

9 Press the **END** key several times to return to LOCAL.



- The setting configured here is not reflected in the automatic cutting during printing. When you set automatic cutting during printing, see "AUTO CUT" (☞ P.3-27) in Extended Functions - Printer.
- The "AUTO CUT" is not performed when "1" or higher value is set to the take-up timing (☞ P.4-37). (Take up has priority.)

Dividing and Cutting

When the function of dividing and cutting has been set, data that is larger than the width of a medium can be divided and cut. (Dividing and cutting function)

The part that has jugged out from a medium is divided and cut.

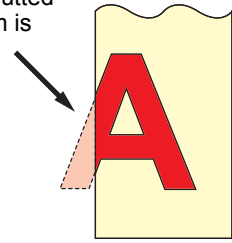

- The following convenient functions can be used with the dividing and cutting function.

Cutting a frame:

Along with the cut data, a frame that fits the size of the cut data is automatically cut.

Attaching marks for pasting:

You can attach marks for pasting two media produced by dividing and cutting a medium.

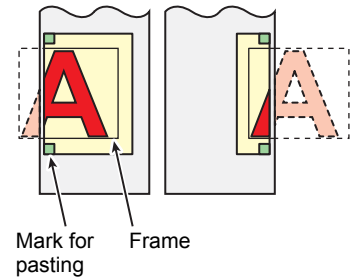

Setting the Dividing and Cutting Function

1

Press the **MODE CHANGE** key in LOCAL to select the cutting mode.

```
<LOCAL .C>      [#01]
CUT1 ( 30 / 60 / 0.30)
```

2

Press the **FUNCTION** key.

```
FUNCTION
SETUP          <ENT>
```

3

Press the **ENTER** key.

```
SETUP
SELECT          :CUT1
```

4

Press **▼** **▲** to select one from the tool conditions (CUT1 to CUT3, PEN, and HALF) and press the **ENTER** key.

5

Press **▼** **▲** to select [DIVISION CUT].

```
[CUT1]
DIVISION CUT   <ent>
```

6

Press the **ENTER** key.

```
[CUT1]DIVISION CUT
SETUP          :OFF
```

7

Press **▼** **▲** to select "ON" and press the **ENTER** key.

```
[CUT1]DIVISION CUT
FRAME CUT     :ON
```

- When having selected "OFF", proceed to Step 11.



4

Extended Functions – Cutting –

8

Press   to select [FRAME CUT] and press the  key.

- When you want to cut a frame, select "ON".

```
[CUT1]DIVISION CUT
FRAME CUT          :OFF
```

9

Press   to select [MARK CUT] and press the  key.

- When you want to attach marks for pasting, select "ON".

```
[CUT1]DIVISION CUT
MARK CUT           :ON
```

10

Press the  key several times to return to LOCAL.

Important!

- The set values are recorded even when the power has been turned OFF.
- Because a mark for pasting is 1 cm long, the width of an effective cut area needs to be 1 cm or more.
- During the operation of dividing and cutting, data sent from the host computer is ignored.
- Dividing and Cutting cannot be performed in any of the following cases:
 - When the data size is larger than the reception buffer capacity
 - When an origin change command is contained in the cut data
 - When register mark detection is performed
 - When the width of an effective cut area is 1 cm or less
 - When the test data stored in this machine has been cut

Cancelling the Setting of Dividing and Cutting



Cutting Data by Using the Dividing and Cutting Function

1

Data is received from the computer.

- When data has jugged out from the cut area, a screen shown right appears.

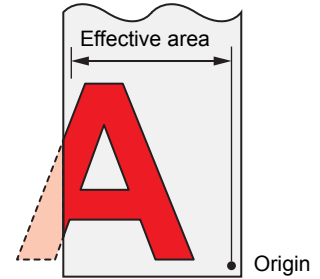

```
*REMOTE .G* < 100KB>
** OFF SCALE **
```

2

When cutting has been complete, the frame and marks for pasting are automatically cut.

```
** DIVISION **
```

3

When the frame has been cut, the screen returns to LOCAL.

- Do not replace a medium when this screen does not appear.

```
<LOCAL .G> [ #01 ]
** DIVISION **
```

4

Set a new origin.

- Move the carriage using the jog keys and set an origin.
- When there is no space to be cut, replace the medium.

5

Press the **REMOTE key to go to the remote mode.**

- The medium is fed by the maximum medium length of the cut data and cut.
- When the medium is not fed or the length of the medium is short, replace the medium with a larger one in Step 4.

Important! • Cut does not start if new origin was not set in Step 4.

6

Repeat the operations in Steps 4 and 5.

- Repeat the operations until there is no data that exceeds the width of the medium.
- When the operations have been completed, tool conditions are displayed and the screen returns to LOCAL.

```
<LOCAL .G> [ #01 ]
[CUT1] 30 60 0.30
```



4

Extended Functions – Cutting –

Cutting with a Dotted Line

Data to be cut is not cut out completely but is cut with a dotted line.
To perform cutting with a dotted line, you must set the tool condition to "HALF".

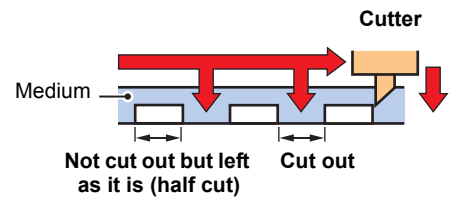

- For cutting a medium with a dotted line, use the sold separately cutter (Model number: SPB-0001, a set of three ultra hard blades).
- Install a pen-line sponge before cutting a medium with a dotted line. (☞ P.1-10)

- Press the **MODE CHANGE** key in LOCAL to select the cutting mode.

<LOCAL .c> [#01]
- Press the **FUNCTION** key.

FUNCTION SETUP <ENT>
- Press the **ENTER** key.

SETUP SELECT : CUT1
- Press **▼▲** to select the tool condition (HALF) and press the **ENTER** key.

SETUP SELECT : HALF
- Press **▼▲** to select [HALF CUT].

[CUT1] HALF CUT <ent>
- Press the **ENTER** key.

[CUT1]HALF CUT SETUP :OFF
- Press **▼▲** to select a cutting pressure for Half cutting.

[CUT1]HALF CUT HALF CUT PRES.= 50g

• Set value: 0 to 300 g
- Press the **ENTER** key.

[CUT1]HALF CUT HALF LENGTH = 0.1mm
- Press **▼▲** to select the length of Half cutting.

[CUT1]HALF CUT HALF LENGTH = 0.1mm

• Set value: 0.1 to 6.0 mm
- Press the **ENTER** key.

[CUT1]HALF CUT CUT LENGTH = 5mm

11 Press   to select the length of the part cut out from the medium.

- Set value: 5 to 150mm

[CUT1]HALF CUT	
CUT LENGTH	= 50mm

12 Press the  key.

13 Press the  key several times to return to LOCAL.

Important!

- When a tool condition other than "HALF" has been selected in Step 4, cutting with a dotted line cannot be set.
- The set values are recorded even when the power has been turned OFF.
- When a medium is cut with a dotted line, the medium is cut along with the backing sheet. Therefore, the life of a cutter blade is shorter than in normal cutting.
- The cutting pressure applied when a medium is cut through can be set by cutting conditions ( P.2-3).

Reference Value

The followings are the cutting condition and dotted line cutting condition when cutting the cutting sheet or the polyvinyl chloride media.

Cutting condition		Condition for cutting with a dotted line	
PRESSURE	100 ~ 150 g	HALF CUT PRES.	30 g
OFFSET	0.30 mm	HALF LENGTH	0.5 mm
		CUT LENGTH	10 mm

The followings are the cutting condition and dotted line cutting condition when cutting 65 kB (kilogram base) media.

Cutting condition		Condition for cutting with a dotted line	
SPEED	40 cm/s	HALF CUT PRES.	0 g
PRESSURE	40 g	HALF LENGTH	0.5 mm
OFFSET	0.30 mm	CUT LENGTH	10 mm



- "CUT LENGTH" needs to be set shorter for characters with many strokes and small characters.



4

Extended Functions – Cutting –

Setting the SORTING

- 1** Press the **MODE CHANGE** key in LOCAL to select the cutting mode.

<LOCAL . **C**> [#01]
 CUT1 (30 / 60 / 0.30)
- 2** Press the **FUNCTION** key.

FUNCTION **C**
 SETUP <ENT>
- 3** Press the **ENTER** key.

SETUP
 SELECT : CUT1
- 4** Press **▼** **▲** to select one from the tool conditions (CUT1 to CUT3, PEN, and HALF) and press the **ENTER** key.
- 5** Press **▼** **▲** to select [SORTING].

[CUT1]
 SORTING <ent>
- 6** Press the **ENTER** key.

[CUT1] SORTING
 SETUP : OFF
- 7** Press **▼** to select "ON".

[CUT1] SORTING
 SETUP : ON
- 8** Press the **ENTER** key.

[CUT1] SORTING
 AUTO FEED : OFF
- 9** Press **▲** **▼** to select [AUTO FEED].

 - When performing AUTO FEED, select "ON".
- 10** Press the **ENTER** key.

[CUT1] SORTING
 AREA : OFF



4

Extended Functions – Cutting –

11

Press   to select a set value of [AREA].

• Set value: OFF or 10 to 5,100 cm (by units of 10 cm)

[CUT 1] SORTING
AREA : 500

12

Press the  key.

13

Press the  key several times to return to LOCAL.

Important!

- The set values are recorded even when the power has been turned OFF.
- When the set value has been changed, the data in the reception buffer is cleared.
- When the sorting function is set to ON, the reception buffer capacity decreases to about 20 MB.

Cancelling the Setting of the SORTING

Perform the operations in Steps 1 to 6 in "Setting the Sorting Function".

Press   to select "OFF".

Press .

Press  several times.

Procedure for SORTING

1 Transmit data.

```
*REMOTE .C* < 100KB>
** SORTING **
```

- The size of the data that has not been processed yet in the reception buffer is displayed. Cutting (plotting with a pen) is not performed. The processed line segments are stored in the sorting buffer.

2 When data transmission has been complete, the waiting time until cutting starts is displayed.

```
*REMOTE .C* < 100%>
** PLOT ** 09s
```

- The remaining time is displayed in units of seconds.
- When no data is received while waiting for the start of cutting, the counter counts down.

3 Perform auto-feeding.

```
*REMOTE .C* < 1%>
** SORTING **
```

- If [AUTO FEED:ON] was selected in Step 9 of Setting the SORTING (☞ P.4-29), AUTO FEED will be performed.
- Before starting of the cutting operation, feed the medium by the amount for the cutting. If the amount of the cutting of the medium is not fed, [ERROR 15-C AUTO FEED] is displayed.
- After replacing the medium with a longer one, perform data transmission or cut the data into pieces according to the specified number (☞ P.4-46).

4 Start cutting.

```
*REMOTE .C* < 100%>
** SORTING **
```

- The already cut data is displayed in percentage.

5 When the cutting has been completed, the screen goes to the remote mode.

```
*REMOTE .C* [ #01 ]
CUT1 ( 30 / 60 / 0.30 )
```



- When sorting is [ON], after receiving the data to be cut, the cutting operation will not start until it completes the operation of the data receiving and the sorting process. However, in the following situation, perform sorting and cutting without waiting.
 - When the sorting buffer is full of data (about 540,000 line segments)
 - When cutting conditions, such as Tool number, SPEED, PRESSURE, have been changed
 - When a feed command or origin change command has been executed



4

Cutting out Data without Register Marks

To print & cut the data without register marks, adjust the misalignment between a printed image and the cutting line (P/C Adjust).



- Before adjusting, set a PVC medium and attach the provided eccentric cutter for cutting.
- Before setting in this section, perform “Setting Media Correction” (👉 P.3-8) in print mode.
- Even if adjusting in this section, some data may be slightly misaligned depending on the print mode, medium features, the pinch roller setting or the other causes. If so, adjust again.
- This function is valid when the firmware Ver.2.10 or later is installed.

The P/C Adjust has the following items.

Set item	Overview
P/C ORIGIN OFFSET	Adjusts the misalignment between the print origin and the cutting origin.
P/C SCALE ADJUST	Adjusts the scale to apply cutting to the correction value of the media-feeding set on the media correction (👉 P.3-8).

Example of the P/C Adjust

This can be set for the conditions of each tool separately. Set it according to the purpose of use.

When using the tool condition [CUT1] to cut the data with the register mark detection.	P/C Adjust is not needed.
When using the tool condition [CUT2] to print & cut the data without register marks.	Perform P/C Adjust.
When using the tool condition [CUT3] only to cut the color medium or the like.	P/C Adjust is not needed.
When using the tool condition [PEN] only to draw with a pen.	P/C Adjust is not needed.

Setting the P/C ORIGIN OFFSET

Adjust the misalignment between the print origin and the cutting origin.

According to the scanning speed in the Y direction, 540dpi and 720dpi has the different ink drop positions while printing. Adjust with the resolution you want to print.



- This machine stores an adjustment value of either 540dpi or 720dpi. Select the resolution of the printing to be performed after adjustment.
- You can set the P/C origin offset for each tool condition.
- When you cut by using two and more tool conditions ([CUT1] and [HALF] etc.) within the same data, set the same adjusting value for each tool condition. If you cut by tool condition with different adjusting value, misalignment may occur.
- When you set the same setting for two and more tool conditions, it is not required to print & cut the adjusting pattern in the second tool condition setting. After performing the Step 8, press key to enter the P/C origin offset value.

1

Set a PVC medium (👉 P.2-15), and attach the eccentric cutter for cutting (👉 P.2-10).

2

Press the key in LOCAL to select the cutting mode.

<LOCAL . > [#01]
CUT1 (30 / 60 / 0.30)

3

Press the key.

FUNCTION
SETUP <ENT>

4 Press the **ENTER** key.

SETUP
 SELECT : CUT1

5 Press **▼▲** to select one from the tool conditions (CUT1 to CUT3, PEN, and HALF) and press the **ENTER** key.

6 Press **▼▲** to select [P/C ADJUST].

[CUT1]
 P/C ADJUST <ent>

7 Press the **ENTER** key twice.

P/C ORIGIN OFS.
 540dpi <ent>

8 Press **▲▼** to select 540dpi or 720dpi, and press the **ENTER** key.

P/C ORIGIN OFS.
 PRINT START :ent

- Select one depending on the resolution you want to print with after adjustment.
- Press **▲▼◀▶** to change the print start position (print origin).
- Press **▶** to go to Step 10.

9 Press the **ENTER** key to print & cut the adjustment pattern.

- The adjustment pattern shown on the right is printed & cut.
- A blue part shows the pattern, and a dotted line part shows the cutting line.

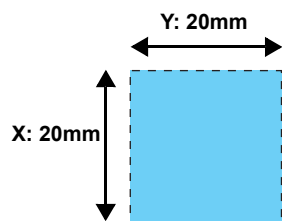

10 Remove the cut pattern, and adjust the misalignment.

P/C ORIGIN OFS.
 X = 2 Y = 3

- Press **▲▼◀▶** to enter an offset value of the cutting line. (approximately 0.05mm per 1 step)

Select X/Y direction : Press **◀▶**.
 Enter an offset value : Press **▲▼**.

The cutting line fits the pattern.	The cutting line is misaligned 0.5mm leftward, and 0.6mm upward.	The cutting line is misaligned 0.4mm rightward, and 0.7mm downward.	The cutting line is misaligned 0.3mm upward.	The cutting line is misaligned 0.2mm rightward.
Y=0, X=0	Y=-10 (0.05x10) X=-12 (0.05x12)	Y=+ 8 (0.05x8) X=+14 (0.05x14)	Y= 0 (0.05x0) X=-6 (0.05x6)	Y=+4 (0.05x4) X= 0 (0.05x0)

11 Press the **ENTER** key.

- Perform the steps from Step 9 again, and repeat until they align.

P/C ORIGIN OFS.
 PRINT START :ent



4

12

Press the **END** key several times to return to LOCAL.



• Even if you adjust with the P/C origin offset, misalignment may occur when you print & cut data actually in some cases. In such a case, you can adjust again by the procedures below:

- (1) Press the **MODE CHANGE** key to select the cutting mode.
- (2) Press the **REMOTE** key to switch to the remote status.
- (3) Press the **FUNCTION** key.
- (4) Adjust by pressing **▲▼◀▶**.
 - Change the direction of X/Y with **◀▶**, and enter the offset value with **▲▼**.

```
P / C  O R I G I N  O F S .
X = 0      Y = 0
```

- (5) Press the **ENTER** key to save the adjusting value.
 - When you save the adjusting value, the value registered with the P/C origin offset is updated.
 - If you do not wish to save the adjusting value, press the **END** key or the **FUNCTION** key.

Setting the P/C SCALE ADJUST

Adjust the scale to apply cutting to the expansion or contraction of the print caused by the media-feeding correction.



- When a medium used or the feeding correction value is changed, readjust it as needed. (When starting to print the pattern, the former setting is initialized.)
- This setting fits the cutting position to the printing position. Please note that the value adjusted here is also applied to cut only or to draw with a pen by PEN tool.
- If you do not want to apply this setting for cutting only, perform the followings.
 - Select "Clear" on Step 9.
 - Cut with a tool condition without the P/C scale correction.

1

Set a PVC medium (☞ P.2-15), and attach the eccentric cutter for cutting (☞ P.2-10).

2

Press the **MODE CHANGE** key in LOCAL to select the cutting mode.

```
<LOCAL .C>      [#01]
CUT1 ( 30 / 60 / 0.30)
```

3

Press the **FUNCTION** key.

```
FUNCTION
SETUP          <ENT> C
```

4

Press the **ENTER** key.

```
SETUP
SELECT          : CUT1
```

5

Press **▼▲** to select one from the tool conditions (CUT1 to CUT3, PEN, and HALF) and press the **ENTER** key.

6

Press **▼▲** to select [P/C ADJUST] .

```
[CUT1]
P / C  A D J U S T      <ent>
```

7 Press the **ENTER** key. [CUT1]P/C ADJUST
P/C ORIGIN OFS.<ent>

8 Press **▼▲** to select **[P/C SCALE ADJ.]**. [CUT1]P/C ADJUST
P/C SCALE ADJ. <ent>

9 Press the **ENTER** key. P/C SCALE ADJ.
CLEAR < > PRINT

10 Press **▶** to print all the pattern and cut the pattern 0.

- The pattern shown on the right is printed.
- To clear the adjustment value, press **◀** and go to Step 16.
- The origin is approximately 300mm away from the pattern 0.

11 Remove the pattern 0, and check the misaligned direction.

- Some are misaligned in the Y direction, but it has no effect on this adjustment.

If the cutting line is misaligned downward, select + direction.

If the cutting line is misaligned upward, select - direction.

12 Press **▼▲** to set **+ / -**. P/C SCALE ADJ.
DIRECTION = +

13 Press the **ENTER** key.

- The machine cuts from the pattern 1 to 9.

14 Remove the pattern from 1, and select one that fits the cutting line and the pattern.

15 Enter the number of the fit pattern, and press the **ENTER** KEY. P/C SCALE ADJ.
ADJ. VALUE = 5

16 Press the **END** key several times to return to LOCAL.

Other Settings

Change the settings according to the types of use.

1

Press the **MODE CHANGE** key in LOCAL to select the cutting mode.

```
<LOCAL .C> [ #01 ]  
CUT1 ( 30 / 60 / 0.30 )
```

2

Press the **FUNCTION** key.

```
FUNCTION  
SETUP <ENT>C
```

3

Press the **ENTER** key.

```
SETUP  
SELECT : CUT1
```

4

Press **▼** **▲** to select one from the tool conditions (CUT1 to CUT3, PEN, and HALF) and press the **ENTER** key.

5

Press **▼** **▲** to select an item to set.

• See "List of Settings" to select one.

6

Press the **ENTER** key.

7

Press **▼** **▲** to select a set value.

• See "List of Settings" to select one.

8

Press the **ENTER** key.

9

Press the **END** key several times to return to LOCAL.

Important!

• The set value is retained even when the power is turned "OFF".



List of Settings

The setting is as follows when purchasing:

Function Name	Overview	Set Value
PINCH ROLLER	Setting the pinch roller pressure and the pinch roller numbers according to the medium to be used.	See P.4-2.
MARK DETECT	See P.4-5.	
CUT MODE (☞ P.4-38)	Normal cutting mode	STD.
	Cutting in a short time (not suitable for heavy media)	FAST
	Cutting mode that prioritizes cutting quality	FINE
AUTO CUT	After cutting has been completed, a medium is cut off automatically.	See P.4-22.
DIVISION CUT	The function of dividing and cutting is set.	See P.4-23.
HALF CUT	The function of cutting with a dotted line is set.	See P.4-26.
UP SPEED	The movement speed of a medium and a carriage when a tool is up is set.	<u>AUTO</u> /5/10/20/30
DUMMY CUT (☞ P.4-38)	The operation of dummy cutting is set.	<u>OFF</u> /ON
MEDIA TYPE *1	The weight of a medium to be mounted is set.	<u>STANDARD</u> / HEAVY
SORTING	The sorting function is set.	See P.4-28.
ADJ-PRS OFFSET (☞ P.4-38)	When there is part of a medium left uncut at the starting and ending points, the value is increased.	0 ~ <u>3</u> ~ 7
TAKEUP TIMMING *2	Set the timing of take-up the medium when the cutting several sheet of data with a register mark or when setting the Multiple Cuttings function.	<u>OFF</u> / 1 to 99 (for one line)
OVER CUT	Set when there is a part remaining uncut because of thick medium etc.	<u>OFF</u> / 0.1mm ~ 1.0mm
VACUUM	The ability to adsorb a medium is set.	<u>STRONG</u> / STANDARD / LittleWEAK / WEAK / OFF

*1. When setting the medium setting to "HEAVY", the cutting speed is limited to 20cm/s.

*2. - When take-up timing is set, the setting of AUTO CUT (☞ P.4-22) will be invalid.

- When take-up timing is set to "1" or higher, the setting of the switch of take-up device is required. (☞ P.2-29)



4

Extended Functions – Cutting –

About the Cutting Mode

Select "FINE" in any of the following cases:

- When characters of which the size is 10 mm or less are cut.
- When pictures or characters that have many sharp corners are cut.
- When minute cutting is required.

However, the edges of a finished pattern may become jagged when the data transmitted from the host computer is too complicated. In such a case, select "FAST" for a smooth finish.

- The cutting speed is limited to 20cm/s for "FINE".

About Dummy Cutting

This is performed after detecting the medium or when changing the tool type in front of the pinch roller which is near the both ends from the position of the cutter unit is placed presently.

Set the dummy cutting function to OFF when you do not want to damage the medium in cutting cut-out characters.

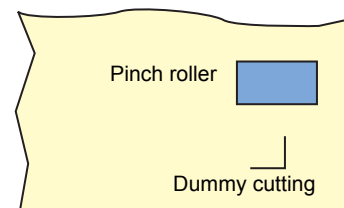

Important!

- When "PEN" is selected for the tool condition, the dummy cutting cannot be set.
- The default of the dummy cutting function is ON.

When you have set the dummy cutting function to OFF, perform test cutting (☞ P.2-43) to adjust the cutter blade orientation before cutting.

About Cutter Blade Corrected Pressure Offset

Some part of a medium is left uncut because the pressure applied when the cutter blade touches the medium is weak.

When an optional eccentric blade is used, some part of a medium to be cut with the blade's angle being 120 degrees or less may be left uncut.

This is because the corners are cut with a low pressure (about 5 g) automatically applied so that the medium does not turn up. Some part of a medium may be left uncut because the blade edge does not rotate smoothly in its moving direction with the cutting pressure being low. In such a case, configure the setting for the pressure to be increased when the corners are cut.

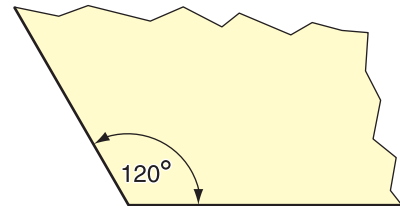

About Over Cutting

Specify whether the over cutting function is enable or unable and the length of the over cutting.

If the length of the over cutting is set, cutting is performed with extra cutting space at the front by the specified amount of length at the start of cutting and tool up is performed at the end going too far.

Over cut : OFF

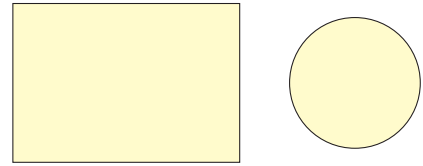

Over cut : 1.0mm

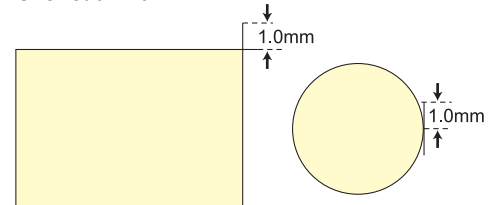

- With setting the over cutting properly, you can reduce the part remaining uncut at the start/end of the cutting, especially for the medium easy to bend. However, too much amount of over cutting causes to scratches on the medium.

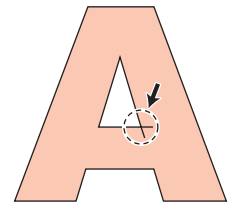

4

Copying the Setting Contents

The setting contents can be copied to other tool conditions.

- 1** Press the **MODE CHANGE** key in LOCAL to select the cutting mode.

```
<LOCAL .C>      [#01]  
CUT1 ( 30 / 60 / 0.30)
```

- 2** Press the **FUNCTION** key.

```
FUNCTION  
SETUP          <ENT>C
```

- 3** Press the **ENTER** key.

```
SETUP  
SELECT          : CUT1
```

- 4** Press **▼** **▲** to select one from the tool conditions (CUT1 to CUT3, PEN, and HALF) and press the **ENTER** key.

- 5** Press **▼** **▲** to select [SETUP COPY].

```
[ CUT1 ]  
SETUP COPY     <ent>
```

- 6** Press the **ENTER** key.

```
[ CUT1 ] SETUP COPY  
CUT1 -> CUT2
```

- 7** Press **▼** **▲** to select the tool condition to copy (CUT1 to CUT3, PEN, HALF or ALL).

```
[ CUT1 ] SETUP COPY  
CUT1 -> CUT3
```

• If "ALL" is selected, the set contents of all tool conditions are same.

- 8** Press the **ENTER** key.

```
COPY  
CUT1 -> CUT3 :ent
```

- 9** Press the **ENTER** key.

- 10** Press the **END** key several times to return to LOCAL.

Important!

• You cannot copy the setting performing with the **USER TYPE/TOOL** key (speed, cutting pressure, offset value).

Initializing the Settings

1 Press the **MODE CHANGE** key in LOCAL to select the cutting mode.

```
<LOCAL .C> [ #01 ]  
CUT1 ( 30 / 60 / 0.30 )
```

2 Press the **FUNCTION** key.

```
FUNCTION  
SETUP <ENT> C
```

3 Press the **ENTER** key.

```
SETUP  
SELECT : CUT1
```

4 Press **▼▲** to select one from the tool conditions (CUT1 to CUT3, PEN, and HALF) and press the **ENTER** key.

5 Press **▼▲** to select [SETUP RESET].

```
[ CUT1 ]  
SETUP RESET <ent>
```

6 Press the **ENTER** key.

```
[ CUT1 ] SETUP RESET  
RESET : ent
```

7 Press the **ENTER** key.
• The set items and parameters are initialized.

8 Press the **END** key several times to return to LOCAL.

Important! • The set value is retained even when the power is turned "OFF".



4

Cutting Samples

In such a case as when data cannot be cut normally, a sample stored in this machine is cut to check the cause of the abnormality.

Sample of "Cut"

Cut

Sample of "Logo"

Mimaki

Important!

- When sample cutting has been performed, data stored in the reception buffer is deleted.
- When detecting the medium and the mode is in print mode, if you perform the sample cut as it is, the following screen will be displayed by pressing the **ENTER** key in Step 10. In this case, press the **ENTER** key to switch the setting of the pinch roller pressure to the cut mode and then perform the sample cut.
- If the **END** key is pressed, switching operation will not be performed.

```
! PR PRESSURE : PRINT!
SWITCH          : ent
```

1 Press the **MODE CHANGE** key in LOCAL to select the cutting mode.

```
<LOCAL .C>      [#01]
CUT1 ( 30 / 60 / 0.30)
```

2 Press the **FUNCTION** key.

```
FUNCTION
SETUP          <ENT>C
```

3 Press **▼▲** to select [MAINTENANCE].

```
FUNCTION
MAINTENANCE   <ENT>C
```

4 Press the **ENTER** key.

```
MAINTENANCE
MARK SENSOR   <ent>
```

5 Press **▼▲** to select [SAMPLE CUT].

```
MAINTENANCE
SAMPLE CUT    <ent>
```

6 Press the **ENTER** key.

```
SAMPLE CUT
SELECT        :CUT
```

7 Press **▼▲** to select sample data to be cut.

- Two samples are available: "CUT" and "LOGO". When having selected "CUT", proceed to Step 10.

```
SAMPLE CUT
SELECT        :LOGO
```

8 Press the **ENTER** key.

```
SAMPLE CUT
LOGO          : 100%
```

9 When cutting LOGO, press **◀▶** to select magnification (1 to 999%).

```
SAMPLE CUT
LOGO          : 200%
```

10 Press the **ENTER** key.

SAMPLE CUT	
CUT START	:ent

11 Press the **ENTER** key to start cutting.

About the Result of Sample Cutting

When sample data can be cut normally, but other data cannot be cut normally

⇒ The host computer has an abnormality.

When both sample data and other data cannot be cut normally

⇒ Increase the set value in [ADJ-PRS OFFSET] (☞ P.4-37) and increase the pressure when the cutter comes down.



Cutting a Medium into Multiple Pieces with a Certain Length

You can cut a medium into multiple pieces with a specified length. (Automatic media-cutting function)

Settings	Set Value	Overview
Cutting interval	10 to 10,000 mm	Distance between the leading and terminal ends of a cut medium is set.
Leading end adjustment cutting	0 to 500 mm	The length of a medium's leading end to be cut is set before automatic media cutting starts. Even when the leading end of a medium has been cut obliquely or the cut surface is not smooth, leading end adjustment cutting enables you to cut a medium into a specified number of pieces with the same length.
Number of times a medium is cut	1 to 9,999	The number of times a medium is cut (number of pieces produced by cutting a medium) is set.

1

Press the **MODE CHANGE** key in LOCAL to select the cutting mode.

<LOCAL .**C**> [#01]

2

Press the **FUNCTION** key.

FUNCTION
SETUP <ENT>**C**

3

Press **▼** **▲** to select [MAINTENANCE] and press the **ENTER** key.

MAINTENANCE
MARK SENSOR <ent>

4

Press **▼** **▲** to select [MEDIA CUT].

MAINTENANCE
MEDIA CUT <ent>

5

Press the **ENTER** key.

MEDIA CUT
INTERVAL = 10mm

6

Press **▼** **▲** to select a cutting interval.

• Set value: 10 to 10,000 mm

MEDIA CUT
INTERVAL = 500mm

7

Press the **ENTER** key.

MEDIA CUT
FRONT CUT OFF= 10mm

8

Press **▼** **▲** to select a length for the leading end adjustment cutting.

• Set value: 0 to 500 mm

MEDIA CUT
FRONT CUT OFF= 50mm

9

Press the **ENTER** key.

MEDIA CUT
COUNT = 1

10

Press **▼** **▲** to select the number of times a medium is cut (number of pieces produced by cutting a medium).

• Set value: 1 to 9,999

MEDIA CUT
COUNT = 10

11 Press the **ENTER** key.

- Cut is performed for the specified number of times.
- Pressing the **END** key suspends the operation.

12 Press the **END** key several times to return to LOCAL.



Perform Multiple Cuttings

Already received data can be copied (plotted with a pen) to produce a multiple number of pieces of data. (Up to 999 pieces)

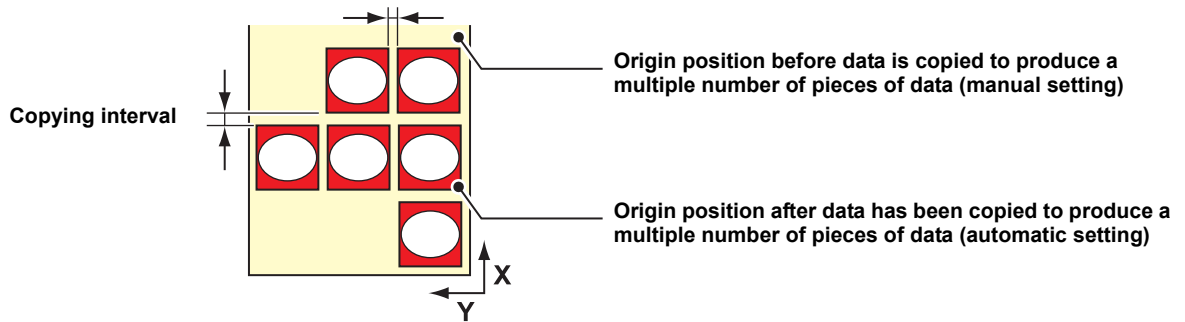

- Copying of data to produce a multiple number of pieces of data is performed with the data stored in the machine's reception buffer being specified.
- Only one piece of data can be stored in the reception buffer.
- When new data is received, it is overwritten on the data that has been stored in the buffer. (The previously received data cannot be specified for it to be copied to produce a multiple number of pieces of data.)



- Press the **MODE CHANGE** key in LOCAL to select the cutting mode.

```
<LOCAL . C> [ #01 ]
CUT1 ( 30 / 60 / 0.30 )
```
- Set an origin.

 - Set the origin referring to P.2-33.
- Press the **FUNCTION** key.

```
FUNCTION
SETUP <ENT> C
```
- Press **▼ ▲** to select [No. COPIES].

```
FUNCTION
No . COPIES <ENT> C
```
- Press the **ENTER** key.

```
No . COPIES
COPIES = 1
```
- Press **▼ ▲** to set the number of pieces of data (1 to 999) produced by copying data.

```
No . COPIES
COPIES = 10
```
- Press the **ENTER** key.

```
No . COPIES
INTERVAL = 0mm
```
- Press **▼ ▲** to select an interval (0 to 30 mm) between figures to be copied.

```
No . COPIES
INTERVAL = 10mm
```
- Press the **ENTER** key.

 - The mode enters to REMOTE automatically, and then the data will be cut.

Important!

- When copying data to produce a multiple number of pieces of data, make sure to set an origin again. When, immediately after data is copied to produce a multiple number of pieces, a piece of data is cut according to a specified number without setting an origin, data is cut (plotted with a pen) with themselves being overlapped.
- While data is being cut into pieces according to a specified number, data from the host computer cannot be received.
- There must be an interval of 10 seconds or more between the preceding data and the succeeding one transmitted from the host computer. When the succeeding data is transmitted within 10 seconds, both two data are cut into pieces according to a specified number.
- Data to be divided and cut is not divided, but cut into pieces according to a specified number. When an error is displayed, see "Error Messages" (☞ P.7-10).

**4**

Setting the Step Size

For some application software (especially old ones), data output may possible only by different unit from the limit of resolution. In such a case, change this setting value and make the cutting performed in correct size.

1

Press the **MODE CHANGE** key in LOCAL to select the cutting mode.

```
<LOCAL .C>      [#01]  
CUT1 ( 30 / 60 / 0.30 )
```

2

Press the **FUNCTION** key.

```
FUNCTION  
SETUP          <ENT>C
```

3

Press **▼** **▲** to select [MAINTENANCE].

```
FUNCTION  
MAINTENANCE   <ENT>C
```

4

Press the **ENTER** key.

```
MAINTENANCE  
MARK SENSOR   <ent>
```

5

Press **▼** **▲** to select [STEP SIZE].

```
MAINTENANCE  
STEP SIZE     <ent>
```

6

Press the **ENTER** key.

```
STEP SIZE  
SIZE          = 0.025
```

7

Press **▼** **▲** to select the setting value.
• Setting value : 0.01 or 0.025

```
STEP SIZE  
SIZE          = 0.01
```

8

Press the **ENTER** key.

9

Press the **END** key several times to return to LOCAL.



Other Convenient Functions

Medium Feeding

Before you start cutting or printing with a pen, feed a certain length of the medium to allow a margin.

By feeding the sheet beforehand, you can check for a skew of the medium or prevent a skew while cutting the long data (or printing the long data with a pen).

Important!

- If you start high-speed cutting without feeding a certain length of the roll medium beforehand, the medium may not be fed properly, causing an error in the machine.
- The **FEED** key does not work until the medium is detected.

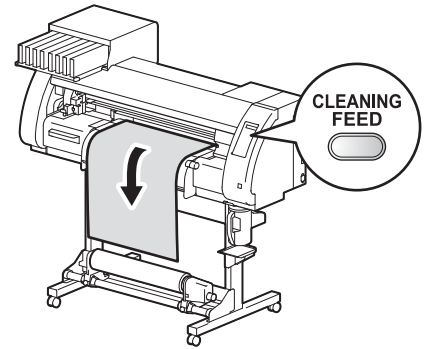

1

Press the **MODE CHANGE** key in LOCAL to select the cutting mode.

```
<LOCAL . C>      [#01]
CUT1 ( 30/ 60/ 0.30)
```

2

Press the **CLEANING/FEED** key.

```
MEDIA FEED
: 0.1m
```

3

Press **▲** **▼** to input the feed amount.

- Set value: 0.1 m to 51.0 m (by the unit of 0.1 m)

```
MEDIA FEED
: 1.5m
```

4

Press the **ENTER** key.

- The medium will be fed by the input length.

```
** MEDIA FEED **
: *.**m
```



- Press the **END** key to stop the medium feeding.



4

Extended Functions – Cutting –

How to turn the heater OFF in the cutting mode

Press the **HEATER/CUTTER** key in the cutting mode to turn the heater OFF.

1

Press the **HEATER/CUTTER** key twice in the cutting mode.

- Pressing the **HEATER/CUTTER** key switches "HEATER Power-off" and "CUT HEAD RETRACT".

HEATER Power - off
<ENT>

HEATER Power - off
<ENT>

↓ ↑ Press the **HEATER/CUTTER** to switch.

CUT HEAD RETRACT
<ENT>

2

Press the **ENTER** key.

- The machine works depending on the setting selected on the step 1.



- Setting above keeps the heater OFF in the cutting mode.
- If switched from the cutting mode to the printing mode, press the **HEATER/CUTTER** key. The machine restarts the control by the heater temperature set in the printing mode.



Chapter 5

Extended Functions – Common Settings –



This chapter

describes the operation procedures for using both the printing and cutting function more conveniently and each setting procedure.

Common Settings	5-2
Setting the Pinch Rollers	5-3
Setting a Cut Method	5-4
Setting CONFIRM. FEED	5-5
Setting the Expand Function	5-6
Setting Margins	5-8
Setting the RECEIVED DATA	5-9
Setting Time	5-10
Setting Units	5-11
Setting the MACHINE NAME	5-12
Setting a KEY BUZZER	5-13
Confirming Machine Information	5-14
Displaying the Information	5-14
Printing the List of Settings	5-16

Common Settings

Common settings are functions for using this machine easily.
The items set here are common to both the printing and cutting modes.

The common settings are as follows:

Item		Set Value ^{*1}	Meaning
PR SETUP ☞ P.5-3		<u>ON</u> / PWR ON ONLY/ PR No.ONLY/ OFF	Sets the setting of a pinch roller when detecting the medium.
CUT METHOD ☞ P.5-4		<u>2 STEP</u> / 3 STEP	The method of cutting a medium with automatic cutting used is set.
CONFIRM. FEED ☞ P.5-5		<u>OFF</u> / 10 ~ 500 mm	A feeding method for confirming the result of test printing can be set. When this is turned ON, the screen changes to "BACK FEED" for returning a medium to the original position by pressing FUNCTION .
EXPANDS ☞ P.5-6		ON / <u>OFF</u>	A printed area or cut area (area plotted with a pen) can be expanded.
MARGIN ☞ P.5-8	LEFT	0 to 85mm (by the unit of 1 mm)	Used to set margins on the right and left edges of a medium.
	RIGHT	0 to 85mm (by the unit of 1 mm)	
RECEIVED DATA ☞ P.5-9		<u>AUTO</u> / MANUAL	This setting can be changed for printing/cutting using an application other than those that come standard with this machine (RasterLinkPro4 or later/FineCut7 or later ^{*2}).
TIME SET ☞ P.5-10			The present date and time are set.
UNIT SETUP ☞ P.5-11	TEMP.	<u>°C</u> / °F	A unit for displaying temperature is set.
	LENGTH	<u>mm</u> / inch	A unit for displaying length and area is set.
MACHINE NAME ☞ P.5-12		<u>01</u> to 99	The names of machines (machine No.) are set for recognizing them when they are connected to one another with a USB 2.0 interface used.
KEY BUZZER ☞ P.5-13		<u>ON</u> / OFF	A buzzer sound when keys are pressed is set.
INFORMATION ☞ P.5-14		_____	Various types of information for confirming the condition of this machine can be checked.

*1. The underlined has been set as default.

*2. When **RL** has not been displayed at the lower left of the dialog of FineCut7 (or later), configure this setting.



Setting the Pinch Rollers

This is the setting methods of a pinch roller when detecting the medium.

Set Value	Overview
ON	The pinch roller number and the pinch roller pressure need to be set each time the medium is set, according to the width of the medium.
PWR ON ONLY	The pinch roller number and the pinch roller pressure need to be set when the medium is set for the first time after the power is turned ON, according to the width of the medium.
PR No. ONLY	The pinch roller number needs to be set each time the medium is set, according to the width of the medium.
OFF	The pinch roller setting is not needed when the medium is set. (The values set with Function are used.)

1 Press the **FUNCTION** key in LOCAL.

FUNCTION
SETUP <ENT>

2 Press **▲** **▼** to select [COMMON SETUP].

FUNCTION
COMMON SETUP <ENT>

3 Press the **ENTER** key twice.

PR SETUP
: ON

4 Press **▲** **▼** to select a set value.
• Set value: ON, PWR ON ONLY, PR No. ONLY, OFF

PR SETUP
: PWR ON ONLY

5 Press the **ENTER** key.

COMMON SETUP
PR SETUP <ent>

6 Press the **END** key several times to end the setting.



Setting a Cut Method

Set the cutting method to cut the medium.

Set Value	Overview
2 STEP	The medium is cut in two steps.
3 STEP	The medium is cut in three steps.

2 STEP

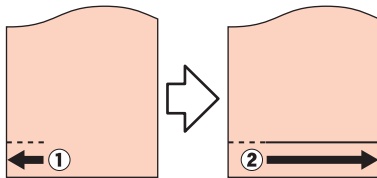

3 STEP

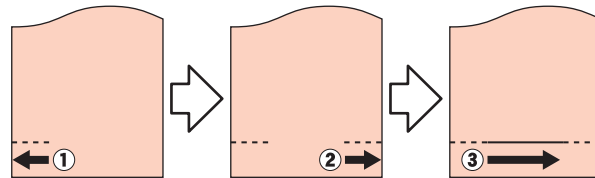

1

Press the **FUNCTION** key in LOCAL.

FUNCTION
SETUP <ENT>

2

Press **▲** **▼** to select [COMMON SETUP].

FUNCTION
COMMON SETUP <ENT>

3

Press the **ENTER** key.

COMMON SETUP
PR SETUP <ent>

4

Press **▲** **▼** to select [CUT METHOD].

COMMON SETUP
CUT METHOD <ent>

5

Press the **ENTER** key.

CUT METHOD
SETUP **2** STEP

6

Press **▲** **▼** to select a set value.

• Set value : 2 STEP, 3 STEP

CUT METHOD
SETUP **3** STEP

7

Press the **ENTER** key.

COMMON SETUP
CUT METHOD <ent>

8

Press the **END** key several times to end the setting.

Setting CONFIRM. FEED

Set whether or not to feed the medium for checking when test printing is finished.

Set Value	Overview
OFF	The medium will not be fed after test printing/cutting.
10 to 500mm	Sets the length to be fed after test printing/cutting. If the length is set, the setting can be set to take up the fed medium a little. (from Step 7)

1

Press the **FUNCTION** key in LOCAL.

```
FUNCTION
SETUP                <ENT>
```

2

Press **▲** **▼** to select [COMMON SETUP].

```
FUNCTION
COMMON SETUP        <ENT>
```

3

Press the **ENTER** key.

```
COMMON SETUP
PR SETUP           <ent>
```

4

Press **▲** **▼** to select [CONFIRM FEED].

```
COMMON SETUP
CONFIRM. FEED     <ent>
```

5

Press the **ENTER** key.

6

Press **▲** **▼** to select the length to be fed (10 to 500mm).

```
CONFIRM. FEED
FEED                : 100mm
```

- When having selected [OFF], proceed to Step 9.

7

Press the **FUNCTION** key to set [BACK FEED].

```
CONFIRM. FEED
BACK FEED          : ON
```

8

Press **▲** **▼** to select ON/OFF.

- ON : To slightly take-up the medium fed by the confirmation feeding function.
- OFF: Not to take-up the medium.

9

Press the **ENTER** key.

```
COMMON SETUP
CONFIRM. FEED     <ent>
```

10

Press the **END** key several times to end the setting.



5

Setting the Expand Function

You can reduce the dead space to thereby expand a printed area or cut area (area plotted with a pen). (Expand function)

The dead space is reduced by 10 mm on the right and left as well as on the side nearest you.

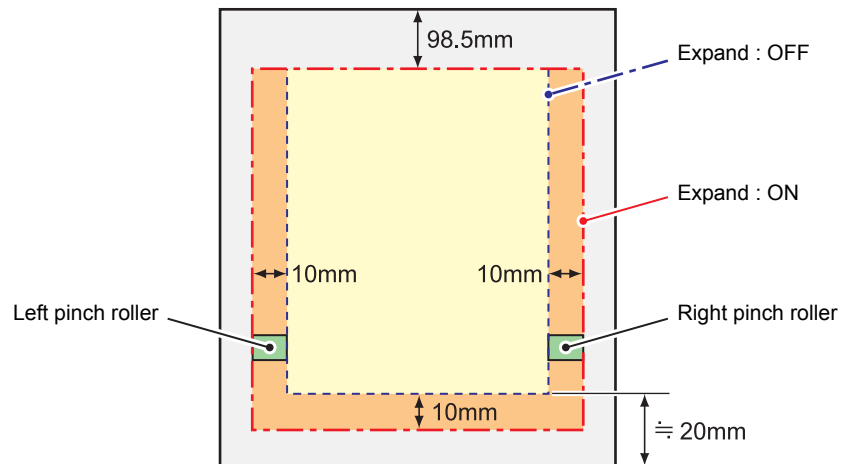

Turning the Expand Function "ON"

Expand function will be enabled after setting of the expand and the medium is detected.

- 1** Press the **FUNCTION** key in LOCAL.

FUNCTION
SETUP <ENT>
- 2** Press **▲▼** to select [COMMON SETUP].

FUNCTION
COMMON SETUP <ENT>
- 3** Press the **ENTER** key.

COMMON SETUP
PR SETUP <ent>
- 4** Press **▼▲** to select [EXPAND].

COMMON SETUP
EXPAND <ent>
- 5** Press the **ENTER** key.

EXPAND
SETUP :OFF
- 6** Press **▼▲** to select "ON".

EXPAND
SETUP :ON
- 7** Press the **ENTER** key.

8

Press the **END** key several times to return to LOCAL.

9

Detect the medium.

- If the clamp lever is released and then reset, medium detection operation starts. Refer to the item 13 and the following procedures of P.2-25.



- Note that, when you use a media holder and turn the Expand function "ON", printing may start on the media holder.
- When you turn the expand function "OFF", perform media detection after selecting "OFF" on Step 6.

Important!

- When you turn the Expand function "ON", a paper jam may occur if excessive pressure is applied to the medium.
- When axis correction has not been performed, the cutter blade can come out of the medium and may cause a paper jam. In addition, a cutter blade having come out of the medium may damage itself or the machine.
- When the cut area is fed by pinch rollers, the cutting quality will deteriorate.
- When pinch rollers move on the register marks during detection, the register marks may not be detected properly.
- If setting expand after detecting the medium, detect the media again. Otherwise, the expand function will not be enabled.

**5**

Setting Margins

The left and right margins of a medium to be printed or cut are set.

Set Item	Set Value	Overview
LEFT	0 to 85 mm	The left margin of a medium to be printed or cut is set.
RIGHT	0 to 85 mm	The right margin of a medium to be printed or cut is set.

1 Press the **MODE CHANGE** key in LOCAL to select the printing mode.

```
<LOCAL . 1>      [#01]
                WIDTH: *****mm
```

2 Press the **FUNCTION** key.

```
FUNCTION
COMMON SETUP  <ENT>
```

3 Press the **ENTER** key.

```
COMMON SETUP
PR SETUP      <ent>
```

4 Press **▲▼** to select [MARGIN].

```
COMMON SETUP
MARGIN        <ent>
```

5 Press the **ENTER** key.

```
LEFT          : RIGHT
0mm           : 0mm
```

6 Press **▲▼◀▶** to set the left and right margins.

Item selection : Select the left or right margin with **◀▶**.
 Margin setting : Set the width of the margin with **▲▼**.

Left margin: 0 to 85 mm (by the unit of 1 mm) Right margin: 0 to 85 mm (by the unit of 1 mm)

```
LEFT          : RIGHT
0mm           : 0mm
```

7 Press the **ENTER** key.

```
COMMON SETUP
MARGIN        <ent>
```

8 Press the **END** key several times to end the setting.





Setting the RECEIVED DATA

The setting can be changed for printing/cutting using an application other than those that come standard with this machine.



Set Value	Overview
AUTO	When the standard application included with the machine is used, printing/cutting will be executed automatically according to the type of the received data.
MANUAL	Set this parameter when executing printing/cutting with the application other than those that come with the machine (RasterLinkPro4 or later/FineCut7 or later *1). In this case, this machine operates as follows. If the machine receives different data, an error occurs. While in PRINT mode : The machine can only receive the print data. If the received data is not the print data, an error occurs. While in CUT mode : The machine can only receive the cut data. If the received data is not the cut data, an error occurs.

*1. When  has not been displayed at the lower left of the dialog of FineCut7 (or later), configure this setting.



- 1** Press the **FUNCTION** key in LOCAL.

FUNCTION
SETUP <ENT>
- 2** Press   to select [COMMON SETUP].

FUNCTION
COMMON SETUP <ENT>
- 3** Press the **ENTER** key.

COMMON SETUP
PR SETUP <ent>
- 4** Press   to select [RECEIVED DATA].

COMMON SETUP
RECEIVED DATA <ent>
- 5** Press the **ENTER** key.

RECEIVED DATA
SETUP :  AUTO
- 6** Press   to select a set value.
• Set value: AUTO, MANUAL
- 7** Press the **ENTER** key.

COMMON SETUP
RECEIVED DATA <ent>
- 8** Press the **END** key several times to end the setting.



Setting Time

1

Press the **FUNCTION** key in LOCAL.

```
FUNCTION
SETUP          <ENT>
```

2

Press **▲** **▼** to select [COMMON SETUP].

```
FUNCTION
COMMON SETUP  <ENT>
```

3

Press the **ENTER** key.

```
COMMON SETUP
PR SETUP      <ent>
```

4

Press **▲** **▼** to select [TIME SET].

```
COMMON SETUP
TIME SET      <ent>
```

5

Press the **ENTER** key twice.

```
TIME SET
2012.09.10  15:30:00
```

6

Press **▲** **▼** **◀** **▶** to enter time.

Select date (year/month/day/hour/minute): Select with **◀** **▶**.
Enter date (year/month/day/hour/minute) : Enter with **▲** **▼**.

7

Press the **ENTER** key.

• The entered date is displayed.

```
TIME SET
2012.09.10  15:30:00
```

8

Press the **END** key several times to end the setting.

Important!

- The time set in the past can be changed until only eight hours before the present displayed time.
- When a future time after the present one has been set by mistake, performing the following operations in Step 7 enables the already set future time to be restored to the previously set time.
(1) Press the **FUNCTION** key in Step 7. (The entered time and the previously set time are displayed.)
(2) Press the **ENTER** key.
If you have made several changes in time setting, only the last time to be set can be restored to the previously set time. In addition, the time before change is ahead by the time that has elapsed.

Setting Units

Units used by this machine are set.

- 1** Press the **FUNCTION** key in LOCAL.

FUNCTION
SETUP <ENT>
- 2** Press **▲** **▼** to select [COMMON SETUP].

FUNCTION
COMMON SETUP <ENT>
- 3** Press the **ENTER** key.

COMMON SETUP
PR SETUP <ent>
- 4** Press **▲** **▼** to select [UNIT SETUP].

COMMON SETUP
UNIT SETUP <ent>
- 5** Press the **ENTER** key.

TEMP. : LENGTH
°C : mm
- 6** Press **▲** **▼** **◀** **▶** to select a unit.
 Item selection : Select one with **◀** **▶**.
 Unit setting : Enter with **▲** **▼**.
- 7** Press the **ENTER** key.

COMMON SETUP
UNIT SETUP <ent>
- 8** Press the **END** key several times to end the setting.



Setting the MACHINE NAME

The names of machines (machine No.) are set for recognizing them when they are connected to one another with a USB 2.0 interface used.

1 Press the **FUNCTION** key in LOCAL. FUNCTION
SETUP <ENT>

2 Press **▲▼** to select [COMMON SETUP]. FUNCTION
COMMON SETUP <ENT>

3 Press the **ENTER** key. COMMON SETUP
PR SETUP <ent>

4 Press **▲▼** to select [MACHINE NAME]. COMMON SETUP
MACHINE NAME <ent>

5 Press the **ENTER** key. MACHINE NAME
CJV30-0**1**

6 Press **▲▼** to select a machine name (01 to 99). MACHINE NAME
CJV30-1**0**

7 Press the **ENTER** key. COMMON SETUP
MACHINE NAME <ent>

8 Press the **END** key several times to end the setting.



Setting a KEY BUZZER

A buzzer sound when keys are pressed is set.

- 1** Press the **FUNCTION** key in LOCAL.

FUNCTION
SETUP <ENT>
- 2** Press **▲** **▼** to select [COMMON SETUP].

FUNCTION
COMMON SETUP <ENT>
- 3** Press the **ENTER** key.

COMMON SETUP
PR SETUP <ent>
- 4** Press **▲** **▼** to select [KEY BUZZER].

COMMON SETUP
KEY BUZZER <ent>
- 5** Press the **ENTER** key.

KEY BUZZER
SETUP : ON
- 6** Press **▲** **▼** to select ON/OFF.

KEY BUZZER
SETUP : OFF
- 7** Press the **ENTER** key.

COMMON SETUP
KEY BUZZER <ent>
- 8** Press the **END** key several times to end the setting.







- When the key buzzer is set to "OFF", the buzzer sound for errors, warnings, operation completion, etc. cannot be shut off.



Confirming Machine Information

The information of this machine can be confirmed. The following items can be confirmed as machine information.

Item	Overview
Error history	This displays the history of errors and warnings to date. When you press   , the date of occurrence (year/month/day/hour/minute) and the error/warning information are displayed alternately in the order of occurrence.
Maintenance history	This displays the date and time when the maintenance function was used. The maintenance history mainly describes the manual and automatic (regular or sleep mode) cleaning functions.
Printing mode history	This displays the information of online printing (printing conditions) that has been performed to date since the machine's power-on. (Up to 50 pieces of information) When you press   , the information is displayed in the order of printing.
List	This allows you to print the settings of the machine. You can print the settings according to four categories. (P.5-16)
Ink REPL. Report *1	Prints history of ink used on the machine.
Version	This displays the version information of the machine.
Serial and Dealer No.	This displays serial and dealer numbers.

*1. This function is available for the firmware Ver. 2.40 and later.

Displaying the Information

1 Press the  key in LOCAL.

- When you want to print the list of settings of this machine, set a medium. (P.2-15)

```
FUNCTION
SETUP                <ENT>
```

2 Press   to select [COMMON SETUP].

```
FUNCTION
COMMON SETUP        <ENT>
```

3 Press the  key.

```
COMMON SETUP
PR SETUP           <ent>
```

4 Press   to select [INFORMATION].

```
COMMON SETUP
INFORMATION        <ent>
```

5 Press the  key.

```
INFORMATION
ERROR HISTORY      <ent>
```

6 Press   to select a type of information.

7 Press the  key.

- The Information you need is displayed.
- When [List] or [Ink REPL. Report] is selected, the machine information is printed.



About Displayed Information

This section describes how to read displayed information.

<p>Error history</p> <p>The date of occurrence (year/month/day) is displayed.</p> <div style="border: 1px solid black; padding: 5px; width: fit-content; margin: 5px auto;">ERROR HISTORY 0001 12.10.10 12:15</div> <p style="text-align: center; margin: 10px 0;">◀ ▶</p> <p>The details of an error is displayed.</p> <div style="border: 1px solid black; padding: 5px; width: fit-content; margin: 5px auto;">***** ERROR 09 ***** HDC ERROR (----)</div>	<p>Maintenance history</p> <p>The details of maintenance is displayed.</p> <div style="border: 1px solid black; padding: 5px; width: fit-content; margin: 5px auto;">0001 12.10.10 12:15 >> CARRIAGE OUT</div> <p>Version</p> <p>Version information, such as F/W, is displayed.</p> <div style="border: 1px solid black; padding: 5px; width: fit-content; margin: 5px auto;">CJV30-60 V3.00 MRL-III V1.00</div>
<p>Printing mode history</p> <p>Resolution, length of a printed medium, etc. are displayed.</p> <div style="border: 1px solid black; padding: 5px; width: fit-content; margin: 5px auto;">[01] 720x1080 .12 Bd.Vd.x1.1L: 12.34m</div> <p style="text-align: center; margin: 10px 0;">◀ ▶</p> <p>The date (year/month/day) of printing is displayed.</p> <div style="border: 1px solid black; padding: 5px; width: fit-content; margin: 5px auto;">PRINTmodeHIST. [01] 12.10.10 12:15</div>	<p>Serial and Dealer No.</p> <p>Serial and dealer numbers are displayed.</p> <div style="border: 1px solid black; padding: 5px; width: fit-content; margin: 5px auto;">S/N = ***** D/N = *****</div>



Printing the List of Settings

You can print the settings of this machine by selecting one from the following four types.

List Type	Overview
Printing mode	The settings in the printing mode are printed.
Cutting mode	The settings in the cutting mode are printed.
Running meter	A running meter is printed.
All	All lists are printed.

Important!

- When detecting the medium and the mode is in cut mode, if you perform printing in the list as it is, the following screen will be displayed by pressing the **ENTER** key in Step 7. In this case, press the **ENTER** key to switch the setting of the pinch roller pressure to the print mode and then perform printing.
- If the **END** key is pressed, switching operation will not be performed.

```
! PR PRESSURE : CUT !
SWITCH                : e n t
```

1

Press the **FUNCTION** key in LOCAL.

- When you want to print the list of settings of this machine, set a medium. (☞ P.2-15)

```
FUNCTION
SETUP                <ENT>
```

2

Press **▲** **▼** to select [COMMON SETUP].

```
FUNCTION
COMMON SETUP        <ENT>
```

3

Press the **ENTER** key.

```
COMMON SETUP
PR SETUP            <e n t>
```

4

Press **▲** **▼** to select [INFORMATION].

```
COMMON SETUP
INFORMATION         <e n t>
```

5

Press the **ENTER** key.

```
INFORMATION
ERROR HISTORY       <e n t>
```

6

Press **▲** **▼** to select [LIST].

```
INFORMATION
LIST                 <e n t>
```

7

Press the **ENTER** key.

8

Press **▲** **▼** to select a list to print.

```
LIST
SELECT : PRINT MODE
```

9

Press the **ENTER** key.

- Printing starts.



Chapter 6

Maintenance



This chapter

describes the items required to use this machine more comfortably, which are the methods for the daily care, the maintenance of the ink unit etc.







Maintenance	6-2	Setting the Tube Washing Interval in the Sleep Mode	6-25
Precautions for Maintenance	6-2	Setting the Cleaning Interval in the Sleep Mode	6-26
About Cleaning Solution	6-2	Setting Regular Operations	6-27
Cleaning the Exterior Surfaces	6-3	Setting the Regular Wiping Operation during a Printing Operation	6-28
Cleaning the Platen	6-3	Setting the Refreshing Interval in the Standby Mode	6-30
Cleaning the Media Sensor and Register Mark Sensor	6-4	Setting the Interval between Each PUMP Tube Washing Operation in the Standby Mode	6-31
Cleaning the Medium Holder	6-4	Setting the Cleaning Interval in the Standby Mode	6-32
Maintaining the Capping Station	6-5	Other Maintenance Functions	6-33
Cleaning the Wiper and Cap	6-6	Changing the Time When a Warning about Wiper Replacement Is Issued	6-33
Replacing the Wiper	6-8	Setting the Display of Media Residual	6-34
Before Washing the Ink Discharge Passage	6-9	White Ink Maintenance Function	6-36
Cleaning the Head Nozzles	6-11	If a Waste Ink Tank Confirmation Message Appears	6-38
Washing the Ink Discharge Passage (PUMP Tube Washing)	6-13	Changing the ink	6-42
When the Machine Is Not Used for a Long Time (CUSTODY WASH)	6-14	Replacing the Cutter Blade	6-43
Cleaning the Ink Head and the Area around It	6-16	Replacing the Pinch Rollers	6-45
When Nozzle Clogging Cannot Be Solved	6-18	Replacing a Cutter Blade Not Included in the Accessories	6-46
FILL UP INK	6-18		
DISCHARGE & WASH	6-19		
Supplying the Machine with Ink Anew	6-21		
Preventing Nozzle Clogging When the Power Is OFF	6-23		
Setting the Refreshing Interval in the Sleep Mode	6-24		

Maintenance

Maintain the machine regularly or as necessary so that its accuracy will be maintained and it can continue to be used for a long time.

Precautions for Maintenance

Pay attention to the following items when maintaining this machine.

	<ul style="list-style-type: none"> When using cleaning solution for maintenance, be sure to wear the supplied protective glasses.
	<ul style="list-style-type: none"> The ink contains organic solvent. When cleaning the machine, be sure to wear gloves so that no ink will make direct contact with your skin.
	<ul style="list-style-type: none"> Never disassemble the machine. Disassembling it can result in electric shock hazards or damage to the machine. Before maintenance, be sure to turn off the power switch and unplug the power cable; otherwise, an unexpected accident may occur.
	<ul style="list-style-type: none"> Prevent moisture from entering the machine. Moisture inside the machine can cause electric shock hazards or damage to the machine.
	<ul style="list-style-type: none"> To ensure stable ink jetting, it is necessary for the machine to eject a small amount of ink (flushing) regularly when a printing (outputting) operation has not been performed for a long time. When the machine is not to be used for a long time, turn off only the power switch on the front side, leave the main power switch at the rear turned ON (in the position of), and leave the power cable connected.
	<ul style="list-style-type: none"> If organic solvent ink is mixed with water or alcohol, coagulation is generated. Do not wipe the nozzle face of the heads, wiper, caps, etc. with water or alcohol. Doing so can cause nozzle clogging or machine failure.
	<ul style="list-style-type: none"> Do not use benzene, thinner, or any chemical agent containing an abrasive. Such materials can deteriorate or deform the surface of the cover.
	<ul style="list-style-type: none"> Do not apply a lubricant, etc. to any parts inside the machine. Doing so can cause damage to the plotter mechanism.
	<ul style="list-style-type: none"> Be careful that the cleaning solution, ink, etc. not to stick to the cover because this may cause the surface of the cover to deteriorate or deform.

About Cleaning Solution

Use cleaning solution for maintenance that can be applied to the ink you use.

Ink type	Applicable cleaning solution for maintenance
SS21 solvent ink	Cleaning solution MS2/ES3/HS kit (SPC-0369) MILD SOLVENT WASHING LIQUID (SPC-0294) [Sold separately]
ES3 solvent ink	
Eco-PA1 ink	Cleaning Liquid Bottle Kit A29 (SPC-0137) [Sold separately] Washing liquid (SPC-0259) [Sold separately]

Cleaning the Exterior Surfaces

When the exterior surfaces of the machine are stained, dampen a soft cloth with water or a neutral detergent diluted with water, squeeze it, and wipe the surfaces with the cloth.

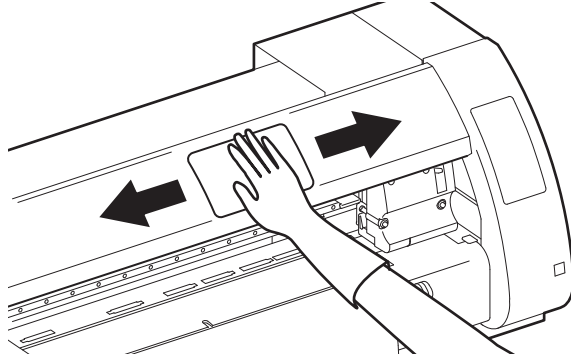

Cleaning the Platen

The platen easily gets dirty with lint, paper dust, etc. generated when a medium is cut. Wipe off conspicuous stains with a soft-hair brush, a dry cloth, a paper towel, etc.



- When the platen is stained with ink, wipe it off with a paper towel containing a small amount of cleaning solution for maintenance.

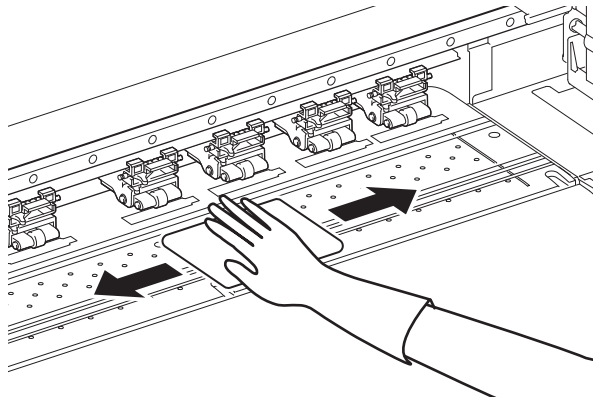

Important!

- Before cleaning the platen, make sure that the platen has cooled adequately.
- Because dust and dirt are easily accumulated in the slots for holding a medium and cutting paper (cutter line), be sure to clean these parts carefully.

Cleaning the Media Sensor and Register Mark Sensor

When the sensor is covered with dust, etc., it may cause false detection of media or register marks. Using a cotton swab, remove the dust, etc. accumulated on the surface of the sensor.

When cleaning the sensor on the undersurface of the cutter unit, perform the operations on P. 6-16 "Cleaning the Ink Head and the Area around It" Steps 1 and 2 and move the carriage to the left end.

Media sensor: On the platen at the rear

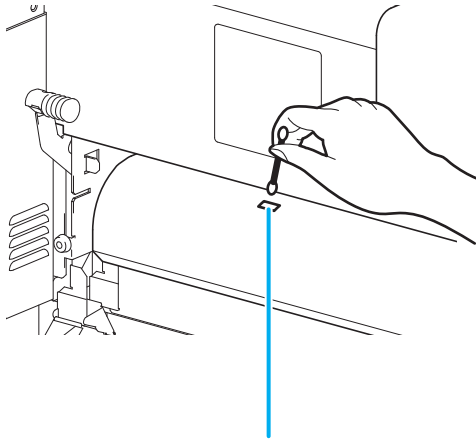

Media sensor

Register mark sensor: On the undersurface of the cutter unit

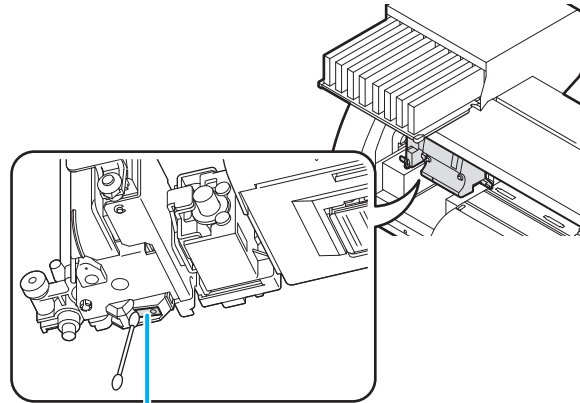

Mark sensor

Cleaning the Medium Holder

When the medium holder is covered with lint, dust, etc., a medium cannot be fed normally during printing or dust sticks to the nozzles, which may result in abnormal printing.

Clean the medium holder regularly.

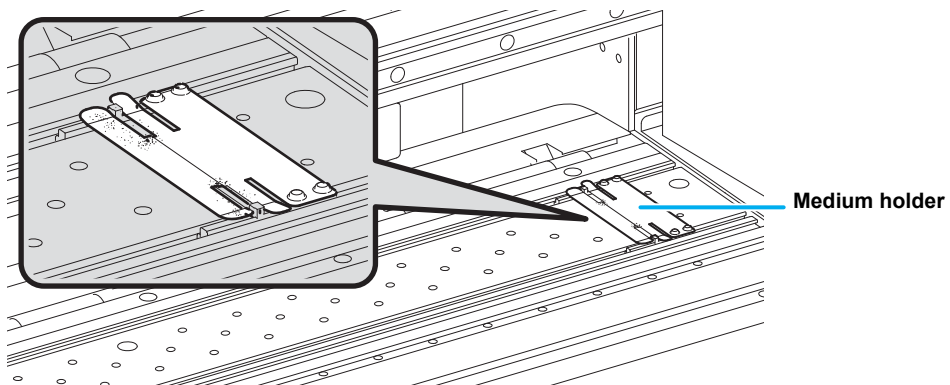

Maintaining the Capping Station

Maintain the ink cap, wiper, etc. located in the capping station. (ST.MAINTENANCE)

The ink cap and wiper function as follows.

- **Wiper** : It wipes off ink sticking to the head nozzles.
- **Ink cap** : It prevents the head nozzles from clogging due to dryness.

As the machine is used repeatedly, the wiper and ink cap gradually become dirty with ink, dust, etc. If nozzle missing cannot be corrected even after head cleaning (☞ P.2-39) has been performed, use a cleaning kit and clean stick.

Tools required for maintenance	• Kit of cleaning solution for maintenance Cleaning solution MS2/ES3/HS kit (SPC-0369)		
	• Clean stick (SPC-0527)	• Gloves	• Goggles

 Caution	<ul style="list-style-type: none"> • Be sure to wear the supplied goggles and gloves when maintaining the capping station. Otherwise, you may get ink in your eyes. • Do not move the carriage out of the capping station by hand. When you want to move the carriage, perform the operations on P.6-6 Steps 1 and 4.
---	---

Cleaning the Wiper and Cap

It is recommended that the wiper and cap be cleaned frequently in order to maintain the high image quality of the machine and keep the machine itself in good working order.

Important!

- When SS21 ink is used, the ink easily sticks around the wiper. Clean the wiper and the area around it about twice a week (it varies, depending on frequency in the use of the machine).
- Replace the wiper with a new one when it is extremely dirty or bent. (☞ P.6-8)
- When cleaning the wiper, be careful that lint from the clean stick does not get left on the wiper. Remaining lint may cause image quality to deteriorate.

- 1** Press the **MODE CHANGE** key in LOCAL to select the printing mode.

<LOCAL . 1> [# 0 1]
WIDTH : * * * * mm

- 2** Select [ST. MAINTENANCE] of the maintenance menu.

- (1) Press the **FUNCTION** key.
(2) Press **▲** **▼** to select [MAINTENANCE] and press the **ENTER** key.

- 3** Press the **ENTER** key.

ST . MAINTENANCE
CARRIAGE OUT <ent>

- 4** Press the **ENTER** key.
- The carriage moves onto the platen.

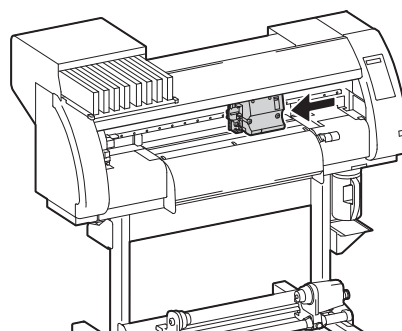

- 5** Remove the wiper.
- Pull out the wiper by holding the protrusions at its both ends.

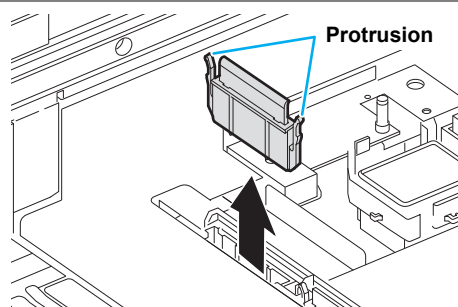

- 6** Clean the wiper and bracket.
- Wipe off the ink sticking to the wiper and bracket with a clean stick dipped in cleaning solution for maintenance.

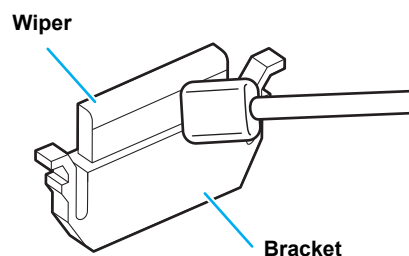

7

Clean the wiper slider.

- Wipe off the ink sticking to the wiper slider with a clean stick dipped in cleaning solution for maintenance.

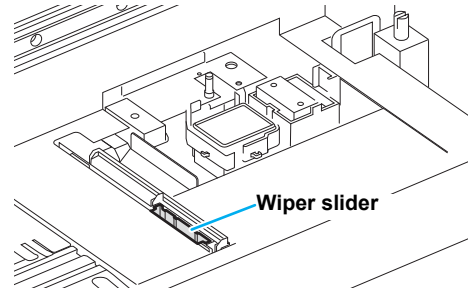

8

Return the wiper to its original position.

- Insert the wiper by holding its both ends.

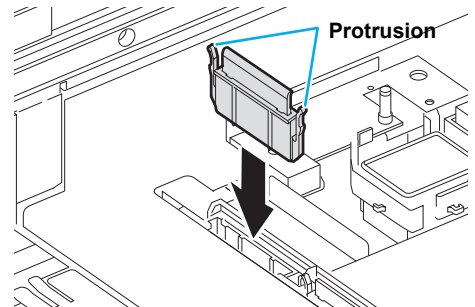

9

Clean the cap rubber and wiper cover.

- Wipe off the ink sticking to the cap rubber and wiper cover with a clean stick dipped in cleaning solution for maintenance.

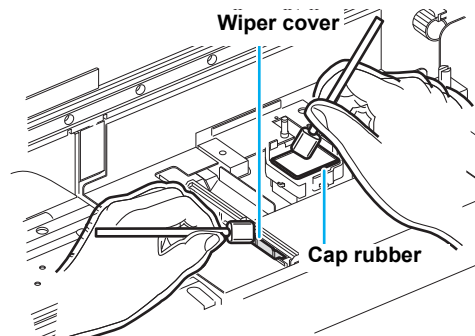

10

Press the **ENTER key.**

- After its initial operation, the machine returns to LOCAL.

Being Initialized
PLEASE WAIT

P

6

Maintenance

Replacing the Wiper

The wiper is consumable. When the message shown on the right appears, replace the wiper immediately.
In addition, wipe off the ink sticking to the undersurface of the slider.

<LOCAL . 1> [# 0 1]
Replac e a WIPER<MNT>

Important!

- A cleaning wiper is an option. Buy one through the dealer in your region or at our service office.
- Do not select [WIPER REPLACE] at any time other than when the wiper is replaced. Once it is selected, the counter that counts the number of times the wiper is used is reset.

1

Press the **MODE CHANGE** key in LOCAL to select the printing mode.

<LOCAL . 1> [# 0 1]
WIDTH : * * * * mm

2

Select [ST. MAINTENANCE] of the maintenance menu.

- (1) Press the **FUNCTION** key.
- (2) Press **▲** **▼** to select [MAINTENANCE] and press the **ENTER** key.

3

Press the **ENTER** key.

ST . MAINTENANCE
CARRIAGE OUT <ent>

4

Press **▲** **▼** to select [WIPER REPLACE].

ST . MAINTENANCE
WIPER REPLACE <ent>

5

Press the **ENTER** key.

- The carriage moves onto the platen.

ST . MAINTENANCE
COMPLETED :ent

6

Remove the wiper.

- Pull out the wiper by holding the protrusions at its both ends.

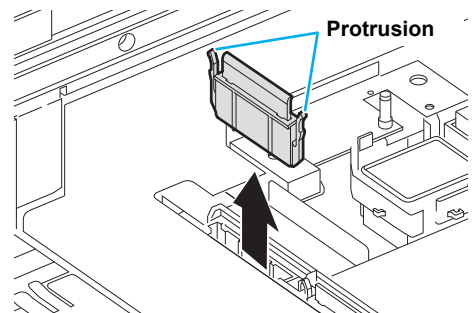

7

Insert a new wiper.

- Insert a new wiper by holding its both ends.

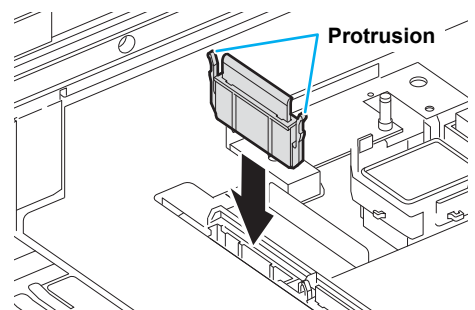

8

Press the **ENTER** key.

- After its initial operation, the machine returns to LOCAL.

Being Initialized
PLEASE WAIT

P

Before Washing the Ink Discharge Passage

Before the ink discharge passage (PUMP tube) is washed, it needs to be filled with cleaning solution for maintenance.



- When the following messages are displayed, check the waste ink tank and perform the operations described on P.6-38 "If a Waste Ink Tank Confirmation Message Appears" as necessary.

Confirm a waste tank
Continue< >Exchange

Confirm a waste tank
Exchange :ent

Filling the Pump Tube with Cleaning Solution for Maintenance

- 1** Press the **MODE CHANGE** key in LOCAL to select the printing mode.

<LOCAL . 1> [#01]
WIDTH: ****mm

- 2** Select [HD. MAINTENANCE] of the maintenance menu.

- (1) Press the **FUNCTION** key.
- (2) Press **▲** **▼** to select [MAINTENANCE] and press the **ENTER** key.
- (3) Press **▲** **▼** to select [HD. MAINTENANCE].
- (4) Press the **ENTER** key.

- 3** Press **▲** **▼** to select [Maint WashLiquid].

HD . MAINTENANCE
MaintWashLiquid<ent>

- 4** Press the **ENTER** key.

MaintWashLiquid
FILLING UP <ent>

- 5** Press the **ENTER** key.

- When a normal cartridge has been set, proceed to Step 7.

MaintWashLiquid
CARTRIDGE : none

When "END" is displayed:

There is no cleaning solution in the cartridge. Set a new cleaning solution cartridge.

When "Abnormal" is displayed:

The set cartridge does not contain cleaning solution.

- 6** Set a cartridge.

MaintWashLiquid
FILLING UP START :ent

- 7** Press the **ENTER** key.

- The cartridge starts to be filled with cleaning solution.

Discharging Cleaning Solution for Maintenance

Perform the following operations to discharge the cleaning solution in the tube.

1

Press the **MODE CHANGE** key in LOCAL to select the printing mode.

```
<LOCAL.1>      [#01]
                WIDTH:****mm
```

2

Select [HD. MAINTENANCE] of the maintenance menu.

- (1) Press the **FUNCTION** key.
- (2) Press **▲** **▼** to select [MAINTENANCE] and press the **ENTER** key.
- (3) Press **▲** **▼** to select [HD. MAINTENANCE].
- (4) Press the **ENTER** key.

3

Press **▲** **▼** to select [Maint WashLiquid].

```
HD.MAINTENANCE
MaintWashLiquid<ent>
```

4

Press the **ENTER** key.

```
MaintWashLiquid
FILLING UP      <ent>
```

5

Press **▲** **▼** to select [DISCHARGE].

```
MaintWashLiquid
DISCHARGE      <ent>
```

6

Press the **ENTER** key.

- When the cartridge has been disengaged, proceed to Step 8.

```
MaintWashLiquid
There is a CARTRIDGE
```

7

Remove the cartridge.

```
MaintWashLiquid
DISCHARGE START :ent
```

8

Press the **ENTER** key.

- The cleaning solution starts to be discharged.



Cleaning the Head Nozzles

The head nozzles need to be washed to prevent them from being clogged with coagulated ink.

Check the items on the right beforehand.

Is [NEAR END] or [INK END] displayed?

- The cleaning solution or ink is absorbed when the nozzles are washed. At this time, if the state of "no ink" or "almost no ink" is detected, the nozzle washing operation cannot start.
- Replace the cartridge with another from which the state of "almost no ink" or "no ink" is not detected.

- 1** Press the **[MODE CHANGE]** key in LOCAL to select the printing mode.

<LOCAL . 1> [#01]
WIDTH : * * * * mm

- 2** Select [ST. MAINTENANCE] of the maintenance menu.

- (1) Press the **[FUNCTION]** key.
(2) Press **[▲]** **[▼]** to select [MAINTENANCE] and press the **[ENTER]** key.

- 3** Press the **[ENTER]** key.

ST . MAINTENANCE
CARRIAGE OUT <ent>

- 4** Press **[▲]** **[▼]** to select [NOZZLE WASH].

ST . MAINTENANCE
NOZZLE WASH <ent>

- 5** Press the **[ENTER]** key.

- The carriage moves onto the platen.

WIPER CLEANING
COMPLETED(NEXT) :ent

- 6** Clean the wiper and bracket.

- (1) Pull out the wiper by holding the protrusions at its both ends.
(2) Clean the wiper and bracket with a clean stick dipped in cleaning solution for maintenance (SPC-0369).
(3) Insert the wiper into the original position by holding the protrusions at its both ends.

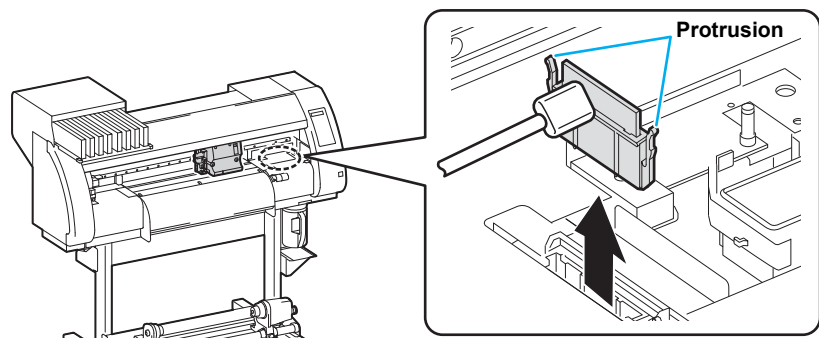

- 7** Press the **[ENTER]** key.

Fill the liquid
COMPLETED(NEXT) :ent

8

Press the **FUNCTION** key and fill up the cap with cleaning solution for maintenance.

- When you press the **FUNCTION** key, cleaning solution drips into the cap.
- When you press the **FUNCTION** key again, the solution stops dripping.
- Repeat the drops several times to fill the cap with the cleaning solution just before the solution overflows from the cap.

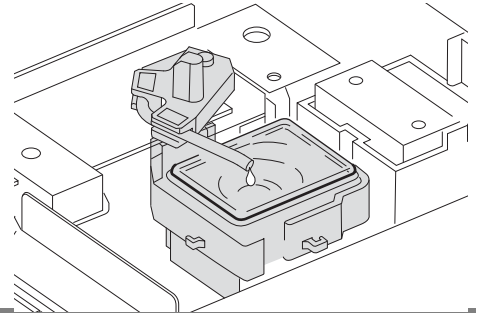
**9**

Press the **ENTER** key.

ST.MAINTENANCE
LEAVING TIME : 1min

10

Press **▲** **▼** to set the time for the cleaning solution to be left as it is.

- Set value: 1 to 99 min (by the unit of 1 min)

ST.MAINTENANCE
LEAVING TIME : 2min

11

Press the **ENTER** key.

- The cleaning solution in the cap is absorbed.
- The screen on the right is displayed for the time set in Step 10.
- When the set time has elapsed, the screen returns to LOCAL.

Being Initialized
PLEASE WAIT



<LOCAL . 1> [#01]

Important!

- When nozzle missing is not corrected even after this cleaning has been performed several times, perform "When Nozzle Clogging Cannot Be Solved" (☞ P.6-18) and "DISCHARGE & WASH" (☞ P.6-19). When the problem is not solved even after the operation above, contact the distributor in your region or our service office.
- When this machine is not filled with cleaning solution for maintenance, do the following:
 - (1) Perform the operations in Steps 1 to 5.
 - (2) Fill up the cap with cleaning solution for maintenance, using a syringe.
 - (3) Perform the operations in Step 9 and later.
- The waste ink discharged by head nozzle cleaning is not counted as the waste ink automatically accumulated in this device (☞ P.6-38). Check the status of the waste ink tank without fail before/after the cleaning.



Washing the Ink Discharge Passage (PUMP Tube Washing)

Wash the ink discharge passage regularly to prevent the head nozzles from clogging due to ink coagulation inside the passage.



- When the following messages are displayed, check the waste ink tank and perform the operations described on P.6-38 "If a Waste Ink Tank Confirmation Message Appears" as necessary.

Confirm a waste tank
Continue < >Exchange

Confirm a waste tank
Exchange :ent

- 1** Press the **MODE CHANGE** key in LOCAL to select the printing mode.

<LOCAL . 1> [# 0 1]
WIDTH : * * * * mm

- 2** Select [ST. MAINTENANCE] of the maintenance menu.

- (1) Press the **FUNCTION** key.
- (2) Press **▲** **▼** to select [MAINTENANCE] and press the **ENTER** key.

- 3** Press the **ENTER** key.

ST . MAINTENANCE
CARRIAGE OUT <ent>

- 4** Press **▲** **▼** to select [PUMP TUBE WASH].

ST . MAINTENANCE
PUMP TUBE WASH <ent>

- 5** Press the **ENTER** key.

- The carriage moves onto the platen.
- Repeat the idle absorbing operation (Absorption for 5 seconds and interruption for 10 seconds) until the washing operation is completed.

ST . MAINTENANCE
COMPLETED :ent

- 6** Press the **FUNCTION** key and fill up the cap with cleaning solution for maintenance.

- When you press the **FUNCTION** key, cleaning solution drips into the cap.
- When you press the **FUNCTION** key again, the solution stops dripping.
- During the idle absorbing is interrupted, repeat the drops several times to fill the cap with the cleaning solution just before the solution overflows from the cap.

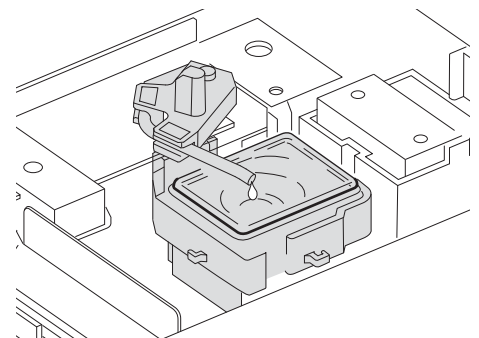

- 7** Press the **ENTER** key.

- After the idle absorbing operation has been performed for 30 seconds, the screen returns to LOCAL.

Being Initialized
PLEASE WAIT

<LOCAL . 1> [# 0 1]



- When this machine is not filled with cleaning solution for maintenance, do the following:
 - Perform the operations in Steps 1 to 5.
 - Fill up the cap with cleaning solution for maintenance, using a syringe.
 - Perform the operation in Step 7.

When the Machine Is Not Used for a Long Time (CUSTODY WASH)

When the machine is not going to be used for a week or more, use the cleaning function for custody to clean the head nozzles and ink discharge passage. After this, keep the machine in custody.

Check the items on the right beforehand.

Is [NEAR END] or [INK END] displayed?

- The cleaning solution or ink is absorbed when the nozzles are washed. At this time, if the state of "no ink" or "almost no ink" is detected, the nozzle washing operation cannot start.
- Replace the cartridge with another from which the state of "almost no ink" or "no ink" is not detected.



- When the following messages are displayed, check the waste ink tank and perform the operations described on P.6-38 "If a Waste Ink Tank Confirmation Message Appears" as necessary.

Confirm a waste tank
Continue < > Exchange

Confirm a waste tank
Exchange :ent

- 1 Press the **MODE CHANGE** key in LOCAL to select the printing mode.

<LOCAL . 1> [#01]
WIDTH : * * * * mm

- 2 Select [ST. MAINTENANCE] of the maintenance menu.

- (1) Press the **FUNCTION** key.
- (2) Press **▲** **▼** to select [MAINTENANCE] and press the **ENTER** key.

- 3 Press the **ENTER** key.

ST . MAINTENANCE
CARRIAGE OUT <ent>

- 4 Press **▲** **▼** to select [COSTODY WASH].

ST . MAINTENANCE
COSTODY WASH <ent>

- 5 Press the **ENTER** key.

- The carriage moves onto the platen.

WIPER CLEANING
COMPLETED (NEXT) :ent

- 6 Clean the wiper and bracket.

- (1) Pull out the wiper by holding the protrusions at its both ends.
- (2) Clean the wiper and bracket with a clean stick dipped in cleaning solution for maintenance (SPC-0369).
- (3) Insert the wiper into the original position by holding the protrusions at its both ends.

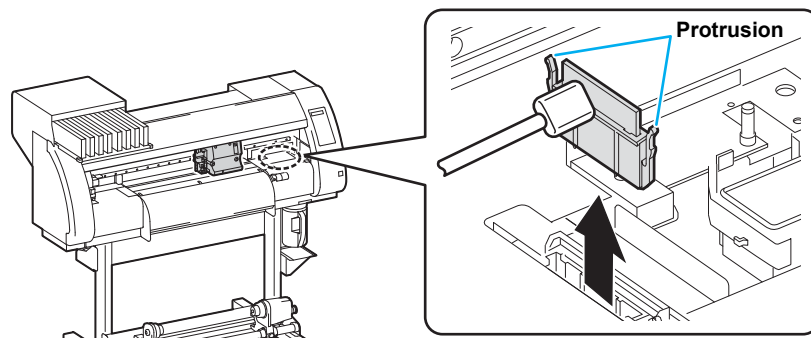

7 Press the **ENTER** key.

Fill the liquid.
COMPLETED(NEXT) :ent

8 Press the **FUNCTION** key and fill up the cap with cleaning solution for maintenance.

- When you press the **FUNCTION** key, cleaning solution drips into the cap.
- When you press the **FUNCTION** key again, the solution stops dripping.
- Repeat the drops several times to fill the cap with the cleaning solution just before the solution overflows from the cap.

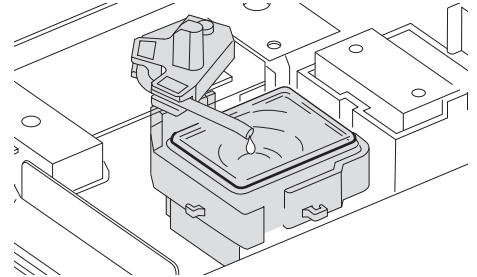

9 Press the **ENTER** key.

ST.MAINTENANCE
LEAVING TIME : 1min

10 Press **▲▼** to set the time for the cleaning solution to be left as it is.

- Set value: 1 to 99 min (by the unit of 1 min)

ST.MAINTENANCE
LEAVING TIME : 2min

11 Press the **ENTER** key.

- The nozzles are washed.
- When the nozzles have been completely washed, the head moves onto the platen.

Being Initialized
PLEASE WAIT

12 Press the **FUNCTION** key and fill up the cap with cleaning solution for maintenance.

- When you press the **FUNCTION** key, cleaning solution drips into the cap.
- When you press the **FUNCTION** key again, the solution stops dripping.
- During the idle absorbing is interrupted, repeat the drops several times to fill the cap with the cleaning solution just before the solution overflows from the cap.

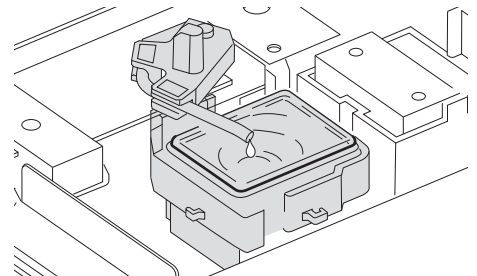

13 Press the **ENTER** key.

- After its initial operation, the machine returns to LOCAL.

Being Initialized
PLEASE WAIT

Cleaning the Ink Head and the Area around It

Because the ink head employs a very precise mechanism, due care needs to be taken when it is cleaned. Using a clean stick, etc., rub off gelatinous ink or dust that may stick to the lower part of the slider and the area around the ink head. In doing so, never rub the nozzles of the head.

Tools needed for cleaning	• Clean stick	• Gloves	• Goggles
----------------------------------	---------------	----------	-----------



- Be sure to wear the attached goggles and gloves when cleaning the area around the ink head. Otherwise, you may get ink in your eyes.
- The ink contains organic solvent. If you get the ink on your skin or in your eyes, wash it away with plenty of water immediately.

1 Press the **(MODE CHANGE)** key in **LOCAL** to select the printing mode.

<LOCAL . 1> [# 0 1]
WIDTH : * * * * mm

2 Select [**CR.MAINTENANCE**] of the maintenance menu.

- (1) Press the **(FUNCTION)** key.
- (2) Press **(▲)** **(▼)** to select [**MAINTENANCE**] and press the **(ENTER)** key.
- (3) Press **(▲)** **(▼)** to select [**CR.MAINTENANCE**] and press the **(ENTER)** key.

CR . MAINTENANCE
Remove the cover : e n t

3 Remove the maintenance cover.

- (1) Turn the two screws that fix the maintenance cover counterclockwise to remove them.
- (2) Remove the maintenance cover.

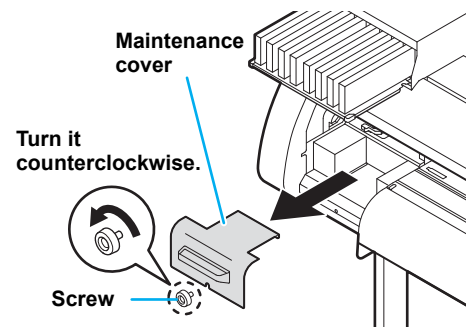

4 Press the **(ENTER)** key.

CR . MAINTENANCE
CARRIAGE OUT : e n t

5 Press the **(ENTER)** key.

- Carriage will move to the left end of this device.



- You can move the carriage manually, however, if you connect the connection unit to the cutter unit, you cannot move it manually because it is locked. If you try to move forcibly, it may cause injury.



6

Wipe off the ink sticking to the side of the ink head with a clean stick.

- Never rub the nozzles.

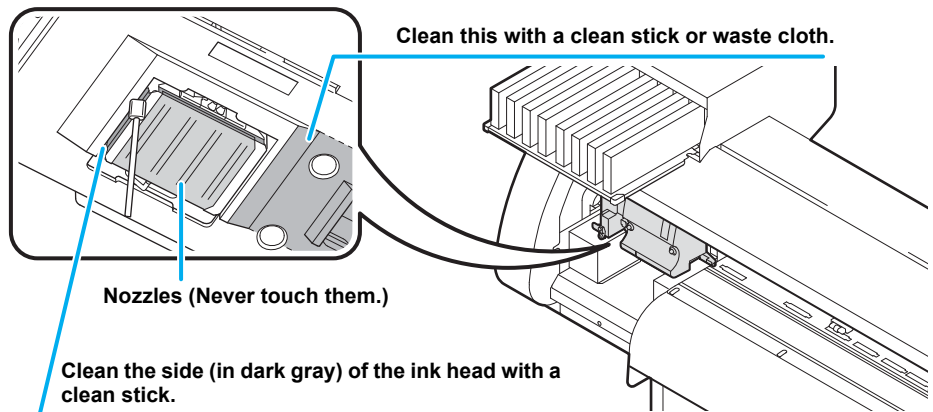

7

When the cleaning has been completed, press the **ENTER key.**

- After its initial operation, the machine returns to LOCAL.

Being Initialized
PLEASE WAIT

Important!

- Because of its property, SS21W-2 ink easily sticks to the area around the ink head. Clean the area around the ink head about twice a week (it varies, depending on the frequency the machine is used).

When Nozzle Clogging Cannot Be Solved

When nozzle clogging cannot be solved even after the ink head cleaning (☞ P.2-39) or head nozzle washing (☞ P.6-11) has been done, perform the following two functions:

FILL UP INK	• Ink is supplied to solve nozzle clogging.
DISCHARGE & WASH	• The head, tube, and damper are washed with dedicated cleaning solution (optional). (☞ P.6-19)

FILL UP INK

- 1** Press the **MODE CHANGE** key in LOCAL to select the printing mode.

```
<LOCAL . 1>      [#01]
                WIDTH: * * * *mm
```

- 2** Select [HD. MAINTENANCE] of the maintenance menu.

- (1) Press the **FUNCTION** key.
- (2) Press **▲** **▼** to select [MAINTENANCE] and press the **ENTER** key.
- (3) Press **▲** **▼** to select [HD. MAINTENANCE].
- (4) Press the **ENTER** key.

- 3** Press the **ENTER** key.

- Ink is supplied automatically.
- When ink has been supplied completely, the screen returns to the shown on the right.

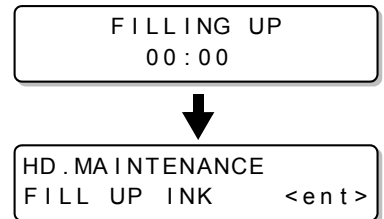

- 4** Press the **END** key several times to end the setting.



DISCHARGE & WASH

Ink is discharged from the head, damper, and tube for them to be cleaned.

Important!

- To use this function, the dedicated cleaning solution (☞ P.6-2 "About Cleaning Solution") is required. In addition, before performing the work, check whether ink to be filled again remains or not.
- When the following messages are displayed, check the waste ink tank and perform the operations described on P.6-38 "If a Waste Ink Tank Confirmation Message Appears" as necessary.

Confirm a waste tank
Continue < > Exchange

Confirm a waste tank
Exchange :ent

1 Press the **MODE CHANGE** key in LOCAL to select the printing mode.

<LOCAL . 1> [#01]
WIDTH : * * * * mm

2 Select [HD. MAINTENANCE] of the maintenance menu.

- (1) Press the **FUNCTION** key.
- (2) Press **▲** **▼** to select [MAINTENANCE] and press the **ENTER** key.
- (3) Press **▲** **▼** to select [HD. MAINTENANCE].
- (4) Press the **ENTER** key.

3 Press **▲** **▼** to select [DISCHARGE & WASH].

MAINTENANCE
DISCHARGE&WASH <ent>

4 Press the **ENTER** key.

Remove : Ink Cartridge
MMCCYYKK

5 Remove the ink cartridge.

- Ink remaining in the head or tube is discharged into the waste ink tank.
- When ink has been discharged completely, the screen on the right appears.

* DISCHARGE *
00 : 00



Set : Washing Cartridge
1 2 3 4 5 6 7 8

6 Mount a cleaning solution cartridge on the ink station.

- The cleaning solution starts to be absorbed.
- When the cleaning solution has been absorbed completely, the screen on the right appears.

* ABSORPTION *
00 : 00



Remove : Cartridges
1 2 3 4 5 6 7 8

7 Remove the cleaning solution cartridge.

- The cleaning solution remaining in the head or tube is discharged into the waste ink tank.
- When the cleaning solution has been discharged completely, the screen on the right appears.

* DISCHARGE *
00 : 00



Set : Washing Cartridge
1 2 3 4 5 6 7 8

8

Mount a cleaning solution cartridge on the ink station.

- The cleaning solution starts to be absorbed.
- When the cleaning solution has been absorbed completely, the screen on the right appears.

* ABSORPTION *
00:00



Remove: Cartridges
12345678

9

Remove the cleaning solution cartridge.

- The cleaning solution remaining in the head or tube is discharged into the waste ink tank.
- When the cleaning solution has been discharged completely, the screen on the right appears.
- Check the state of the waste ink tank and select whether to stop or resume cleaning.
- When you resume cleaning, press to return to Step 6.

* DISCHARGE *
00:00



Maint. Wash Liquid
END< >DISCHARGE

10

Press .

11

Press the key several times to end the operation.



Supplying the Machine with Ink Anew

After you have performed [DISCHARGE & WASH], supply the machine with ink anew with the following operations.

1

Turn on the power of the machine.

- When the power is turned on, the firmware version is displayed following [BOOT].

BOOT

CJV30-60 V* . **

Please Wait

2

Press to select the type of ink to supply to the machine.

- To check the state of the cartridge, press the  key. (P.7-5)

INK TYPE
SS21 Sol

3

Press to select an ink set (set of colors) to supply to the machine.

- You cannot change the current ink set to another by yourself.
- If you want to change the ink set, contact our service office.

SS21 INK SET
4-Color (MMCCYYKK)

4

Press the key.

Set:SS21-4color Ink

5

Mount an ink cartridge on the ink station.

Set : SS21-4 color Ink
--C-Y-KK

FILLING UP NOW.
00:00

- When an ink cartridge has been set, the machine is supplied with ink automatically.
- The ink station has an insertion slot allocated to each ink color. Set the ink cartridge according to the cartridge label under the ink station.

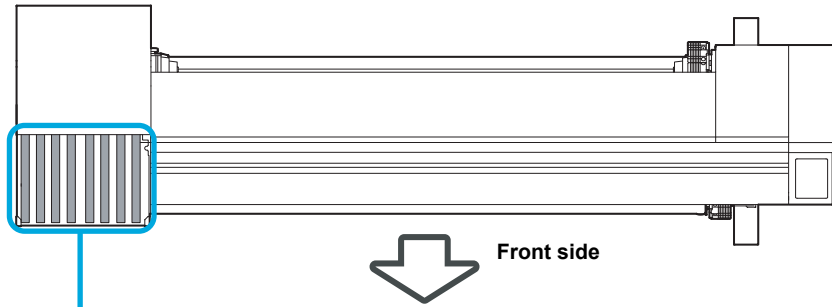

4-color model:	M	M	C	C	Y	Y	K	K
6-color model:	M	Lm	C	M	Lc	C	K	Y
6 colors + white model (SS21W-2):	M	W	C	W	Y	Lm	K	Lc
7 colors model (Eco-PA1):	M	Lk	C	Lk	Y	Lm	K	Lc
8 colors model (ES3): for the firmware V. and later	M	S	C	W	Y	Lm	K	Lc

6

When ink has been supplied to the machine completely, the screen returns to LOCAL.

<LOCAL . 1> [# 0 1]
WIDTH : * * * * mm



- If blurring or missing of characters is found in printing after the machine has been supplied with ink anew, see "Perform head cleaning depending on the test printing result" (P.2-39) or "FILL UP INK" (P.6-18).

When the Machine Cannot Be Supplied with Ink in Step 5

When various ink errors including "Almost no ink" and "No ink" occur, ink does not start to be supplied to the machine.

When ink does not start to be supplied to the machine in Step 5:

- (1) Press the **END** key to return to the screen in Step 2.
- (2) Press the **REMOTE** key to check the state of the ink cartridge.
- (3) Correct ink errors (P.7-5) and repeat the operations from Step 2.

Preventing Nozzle Clogging When the Power Is OFF

Even when the power switch is off, the machine starts regularly and performs various operations to prevent nozzle clogging (Sleep mode). In the sleep mode, the following items can be set:

Set Item	Set Value ^{*1}	Overview
REFRESH	OFF/1 to 168 hours	The interval between each refreshing operation is set.
PUMP TUBE WASH		The interval between each PUMP tube washing operation is set.
CLEANING		The interval between each cleaning operation is set.

*1. The default setting differs, depending on the type of ink you use. The default setting for each ink is as follows:

● Default value for each ink

Ink Type	Refreshing	PUMP Tube Washing	Cleaning
SS21	4 hours	48 hours	OFF
ES3	48 hours	168 hours	OFF
Eco-PA1	48 hours	OFF	OFF

Important!

- When the message on the right is displayed, the operations set in the sleep mode are not performed. Perform the operations described on P.6-38 as necessary.
- When you turn off the power switch on the front side of the machine, check the state of the waste ink tank.

```
<LOCAL.1>      [#01]
Check waste ink<MNT>
```



6

Maintenance

Setting the Refreshing Interval in the Sleep Mode

The interval between each operation of ejecting a small amount of ink from the nozzles to prevent nozzle clogging is set.

1

Press the **MODE CHANGE** key in LOCAL to select the printing mode.

```
<LOCAL . 1>      [#01]  
                WIDTH: ****mm
```

2

Select [SLEEP SETUP] of the maintenance menu.

- (1) Press the **FUNCTION** key.
- (2) Press **▲** **▼** to select [MAINTENANCE] and press the **ENTER** key.
- (3) Press **▲** **▼** to select [SLEEP SETUP].

3

Press the **ENTER** key.

```
SLEEP SETUP  
REFRESH          <ent>
```

4

Press the **ENTER** key.

```
SLEEP SETUP  
REFRESHinterval= 1h
```

5

Press **▲** **▼** to set the refreshing interval.

• Set value: OFF or 1 to 168 hours

```
SLEEP SETUP  
REFRESHinterval= 10h
```

6

Press the **ENTER** key.

```
SLEEP SETUP  
REFRESH          <ent>
```

7

Press the **END** key several times to end the setting.

Setting the Tube Washing Interval in the Sleep Mode

The interval between each operation of washing the cap and PUMP tube with cleaning solution for maintenance in the sleep mode is set.

- 1** Press the **MODE CHANGE** key in LOCAL to select the printing mode.

```
<LOCAL . 1>      [#01]
                WIDTH: ****mm
```

- 2** Select [SLEEP SETUP] of the maintenance menu.

- (1) Press the **FUNCTION** key.
- (2) Press **▲** **▼** to select [MAINTENANCE] and press the **ENTER** key.
- (3) Press **▲** **▼** to select [SLEEP SETUP].
- (4) Press the **ENTER** key.

- 3** Press **▲** **▼** to select [PUMP TUBE WASH].

```
SLEEP SETUP
PUMP TUBE WASH <ent>
```

- 4** Press the **ENTER** key.

```
SLEEP SETUP
WASH INTERVAL = 1h
```

- 5** Press **▲** **▼** to set the interval between each tube washing operation.

```
SLEEP SETUP
WASH INTERVAL = 4h
```

- Set value: OFF or 1 to 168 hours

- 6** Press the **ENTER** key.

```
SLEEP SETUP
PUMP TUBE WASH <ent>
```

- 7** Press the **END** key several times to end the setting.



- When the machine has not been filled with cleaning solution, the screen on the right appears in Step 5. Fill the machine with cleaning solution (☞ P.6-10) and perform the operations in Step 1 and later.
- If the cleaning solution is not set, it does not work.* Set the cleaning solution.

*For [!Wash Liquid END], it works to use up the cleaning solution, however, replace early.

```
** Washing Liquid **
```

```
<LOCAL . C>!WSH [#01]
CUT1 ( 30 / 60 / 0.30 )
```

or

```
<LOCAL . 1>      [#01]
!WashLiquidCart . NONE
```



6

Maintenance

Setting the Cleaning Interval in the Sleep Mode

This is a function operated instead of the pump tube washing when the cleaning solution for maintenance has been used up.

The cleaning type and the interval between each cleaning operation in the sleep mode are set.

1

Press the **MODE CHANGE** key in LOCAL to select the printing mode.

```
<LOCAL . 1>      [#01]
                WIDTH : * * * * mm
```

2

Select [SLEEP SETUP] of the maintenance menu.

- (1) Press the **FUNCTION** key.
- (2) Press **▲** **▼** to select [MAINTENANCE] and press the **ENTER** key.
- (3) Press **▲** **▼** to select [SLEEP SETUP].
- (4) Press the **ENTER** key.

3

Press **▲** **▼** to select [CLEANING].

```
SLEEP SETUP
CLEANING      <ent>
```

4

Press the **ENTER** key.

```
SLEEP SETUP
CLEAN . INTERVAL = 1h
```

5

Press **▲** **▼** to set the interval between each cleaning operation.

- Set value: OFF or 1 to 168 hours

```
SLEEP SETUP
CLEAN . INTERVAL = 4h
```

6

Press the **FUNCTION** key.

- The cleaning type selection screen appears.

```
SLEEP SETUP
CLEAN . TYPE   : NORMAL
```

7

Press **▲** **▼** to select a cleaning type.

- Set value: NORMAL, SOFT, HARD

```
SLEEP SETUP
CLEAN . TYPE   : SOFT
```

8

Press the **ENTER** key.

```
SLEEP SETUP
CLEAN . INTERVAL = 4h
```

9

Press the **END** key several times to end the setting.



Setting Regular Operations

Various regular operations are performed with the power ON to prevent problems, such as ink coagulation, from occurring (Regular settings). For the regular settings, the following items can be set:

Set Item		Set Value	Overview
ROUTINE WIPING	SCAN COUNT	0 to 9,990 times	When the set number of times scanning is performed has been reached during a printing operation, the nozzle face is wiped and dew condensation is removed.
	TEMP. Difference	0 ~ 60°C	When the difference between the set temperature of the print heater and the ambient temperature has exceeded a specified temperature during a printing operation, the nozzle face is wiped and dew condensation is removed.
REFRESH		OFF/1 to 168* ¹ hours	The interval between each refreshing operation is set.
PUMP TUBE WASH			The interval between each PUMP tube washing operation is set.
CLEANING			The interval between each cleaning operation is set.

*1. The default setting differs, depending on the type of ink you use. The default setting for each ink is as follows:

● Default value for each ink

Ink Type	Refreshing	PUMP Tube Washing	Cleaning
SS21	4 hours	48 hours	OFF
ES3	48 hours	168 hours	OFF
Eco-PA1	48 hours	OFF	OFF

Important!

- When the message on the right is displayed, the operations other than [ROUTINE WIPING] in the regular settings are not performed. Perform the operations described on P.6-38 as necessary.
- When you turn off the power switch on the front side of the machine, check the state of the waste ink tank.
- Even if [!RTN] is displayed, the connection unit automatically switches to the printer unit and starts the regular operation when the machine is left unused for a certain period of time.

```
<LOCAL . 1>      [#01]
Check waste ink<MNT>
```

```
<LOCAL . G>!RTN  [#01]
CUT1 ( 30 / 60 / 0.30)
```



6

Maintenance

Setting the Regular Wiping Operation during a Printing Operation

When the set number of times scanning is performed has been reached during a printing operation, a wiping operation is performed automatically to prevent ink dew condensation on the nozzle face.

In the following cases, ink splashing, ink dripping or nozzle missing may occur during a printing operation. It is recommended that the regular wiping operation be set to always maintain a good printing state.

- When the print heater has been set at a high temperature
- When a relatively large value (high density, two coats of ink, etc.) has been set to the amount of ejected ink

The cause of the ink splashing, ink dripping or nozzle missing is that the ink printed immediately after ink ejection is heated by the print heater, which causes evaporated solvent to condense on the nozzle face.

In addition, the larger the difference between the set temperature of the print heater and the ambient temperature is, the more easily the evaporated solvent can condense.

1 Press the **MODE CHANGE** key in LOCAL to select the printing mode.

<LOCAL . 1> [# 0 1]
WIDTH : * * * * mm

2 Select [ROUTINE SETUP] of the maintenance menu.

- (1) Press the **FUNCTION** key.
- (2) Press **▲** **▼** to select [MAINTENANCE] and press the **ENTER** key.
- (3) Press **▲** **▼** to select [ROUTINE SETUP].

3 Press the **ENTER** key.

ROUTINE SETUP
ROUTINE WIPING <ent>

4 Press the **ENTER** key.

ROUTINE WIPING
SCAN COUNT <ent>

5 Press the **ENTER** key.

ROUTINE WIPING
SCAN COUNT = 50

6 Press **▲** **▼** to set the number of times scanning is performed.

ROUTINE WIPING
SCAN COUNT = 40

- Set value: 0 to 9,990 times
- The set value should be 30 to 50 times when the heater temperature has been set at a high one (around 50°C) or when the amount of ejected ink is large, for example, due to two coats of ink.

7 Press the **ENTER** key.

ROUTINE WIPING
SCAN COUNT <ent>

8 Press **▲** **▼**.

- The temperature difference setting screen appears.

ROUTINE WIPING
TEMP . difference <ent>

9 Press the **ENTER** key.

ROUTINE WIPING
TEMP . Difference = 20 ° C

10 Press   to set temperature difference (0 to 60°C).

ROUTINE WIPING
TEMP.Difference=20°C

- When the set temperature of the print heater is higher than the ambient temperature and the difference between the two exceeds a specified temperature, the regular wiping function is activated.

11 Press the  key.

ROUTINE WIPING
TEMP.difference<ent>

12 Press the  key several times to end the setting.

Setting the Refreshing Interval in the Standby Mode

The interval between each refreshing operation is set.

- 1** Press the **MODE CHANGE** key in LOCAL to select the printing mode.

<LOCAL . 1> [# 0 1]
WIDTH : * * * * mm

- 2** Select [ROUTINE SETUP] of the maintenance menu.

- (1) Press the **FUNCTION** key.
- (2) Press **▲** **▼** to select [MAINTENANCE] and press the **ENTER** key.
- (3) Press **▲** **▼** to select [ROUTINE SETUP].
- (4) Press the **ENTER** key.

- 3** Press **▲** **▼** to select [REFRESH].

ROUTINE SETUP
REFRESH <ent>

- 4** Press the **ENTER** key.

ROUTINE SETUP
REFRESHinterval= 1h

- 5** Press **▲** **▼** to set the interval between each refreshing operation.

ROUTINE SETUP
REFRESHinterval= 10h

• Set value: OFF or 1 to 168 hours

- 6** Press the **ENTER** key.

ROUTINE SETUP
REFRESH <ent>

- 7** Press the **END** key several times to end the setting.

Setting the Interval between Each PUMP Tube Washing Operation in the Standby Mode

The PUMP tube is washed regularly to prevent nozzle clogging caused by ink coagulation in the tube.



- This function can be performed only when the states shown by the screens below are maintained.

<LOCAL . 1> [# 0 1]
LOCAL

* REMOTE . 1 * [# 0 1]
0 . 0 0 m
REMOTE

1

Press the **MODE CHANGE** key in LOCAL to select the printing mode.

<LOCAL . 1> [# 0 1]
WIDTH : * * * * mm

2

Select [ROUTINE SETUP] of the maintenance menu.

- (1) Press the **FUNCTION** key.
- (2) Press **▲** **▼** to select [MAINTENANCE] and press the **ENTER** key.
- (3) Press **▲** **▼** to select [ROUTINE SETUP].
- (4) Press the **ENTER** key.

3

Press **▲** **▼** to select [PUMP TUBE WASH].

ROUTINE SETUP
PUMP TUBE WASH <ent>

4

Press the **ENTER** key.

ROUTINE SETUP
WASH INTERVAL = 1h

5

Press **▲** **▼** to set the interval between each PUMP tube washing operation.

- Set value: OFF or 1 to 168 hours

ROUTINE SETUP
WASH INTERVAL = 4h

6

Press the **ENTER** key.

ROUTINE SETUP
PUMP TUBE WASH <ent>

7

Press the **END** key several times to end the setting.



- When the machine has not been filled with cleaning solution, the screen on the right appears in Step 5. Fill the machine with cleaning solution (☞ P.6-10) and perform the operations in Step 1 and later.
- If the cleaning solution is not set, it does not work.* Set the cleaning solution.

*For [!Wash Liquid END], it works to use up the cleaning solution, however, replace early.

WashLiquid UN-FILL

<LOCAL . 9> !WSH [# 0 1]
CUT1 (30 / 60 / 0.30)

or

<LOCAL . 1> [# 0 1]
!WashLiquidCart . NONE



Setting the Cleaning Interval in the Standby Mode

This is a function operated instead of the PUMP tube washing when the cleaning solution for maintenance has been used up.

The cleaning type and the interval between each cleaning operation in the standby mode are set.

Important!

- This function is not performed when ink-related errors, such as "NEAR END" and "INK END", have been occurring.
- While this function is performed, the screen shows the progress that is the same as that of Head cleaning and no key operation can be performed. (☞ P.2-39 "Perform head cleaning depending on the test printing result")
- This function can be performed only when the states shown by the screens below are maintained.

<LOCAL . 1> [# 0 1]
LOCAL

*REMOTE . 1 * [# 0 1]
0 . 0 0 m
REMOTE

- 1** Press the **MODE CHANGE** key in LOCAL to select the printing mode.

<LOCAL . 1> [# 0 1]
WIDTH : * * * * mm

- 2** Select [ROUTINE SETUP] of the maintenance menu.

- (1) Press the **FUNCTION** key.
- (2) Press **▲** **▼** to select [MAINTENANCE] and press the **ENTER** key.
- (3) Press **▲** **▼** to select [ROUTINE SETUP].
- (4) Press the **ENTER** key.

- 3** Press **▲** **▼** to select [CLEANING].

ROUTINE SETUP
CLEANING <ent>

- 4** Press the **ENTER** key.

ROUTINE SETUP
CLEAN . INTERVAL = 1h

- 5** Press **▲** **▼** to set the interval between each cleaning operation.

ROUTINE SETUP
CLEAN . INTERVAL = 4h

- Set value: OFF or 1 to 168 hours

- 6** Press the **FUNCTION** key.

- The cleaning type selection screen appears.

ROUTINE SETUP
CLEAN . TYPE : NORMAL

- 7** Press **▲** **▼** to select a cleaning type.

- Set value: NORMAL, SOFT, HARD

ROUTINE SETUP
CLEAN . TYPE : SOFT

- 8** Press the **ENTER** key.

ROUTINE SETUP
CLEAN . INTERVAL = 4h

- 9** Press the **END** key several times to end the setting.



Setting the Display of Media Residual

Whether the screen displays the remaining amount of a medium is set.

When "Remaining amount of a medium to display" is set to ON,	the remaining amount of a medium is displayed in the remote mode. (However, when a leaf medium is used, the length of the medium to be printed is displayed.)
When "Remaining amount of a medium to display" is set to OFF,	the remaining amount of a medium is not displayed in the remote mode.



- The amount of a medium that has been fed by the printing and jog keys is reflected in the remaining amount of a medium.
- The length of a medium (initial value of the remaining amount) is entered when a roll medium is detected. (P.2-29)
- The setting configured here does not become effective unless media detection is performed after the setting has been complete.

1

Press the **MODE CHANGE** key in LOCAL to select the printing mode.

```
<LOCAL . 1>      [#01]
                WIDTH: ****mm
```

2

Select [MEDIA RESIDUAL] of the maintenance menu.

- (1) Press the **FUNCTION** key.
- (2) Press **▲** **▼** to select [MAINTENANCE] and press the **ENTER** key.
- (3) Press **▲** **▼** to select [MEDIA RESIDUAL].

3

Press the **ENTER** key.

```
MEDIA RESIDUAL
SETUP           : ON
```

4

Press **▲** **▼** to select ON/OFF.

```
MEDIA RESIDUAL
SETUP           : OFF
```

5

Press the **ENTER** key.

```
MAINTENANCE
MEDIA RESIDUAL <ent>
```

6

Press the **END** key several times to end the setting.



Printing the Remaining Amount of a Medium

The present remaining amount of a medium can be printed.



- Set "Remaining amount of a medium to display" to "ON".
- When you replace the medium you use now with another, it is recommended that you print the remaining amount of the medium on it. With the remaining amount of a medium having been printed beforehand, when you use the replaced medium again, you can enter an accurate value in the screen for entering the remaining amount of a medium (P.2-29) that appears after media detection.

1 In LOCAL, Press .

- LOCAL changes to the origin setting mode.

ORIGIN SETUP
 0.0 - - - -

2 Press to set the origin to a desired position.

- Move the carriage and medium with and set the origin.
- When you do not change the origin, do not press and proceed to Step 3.
- When you press the key here, the origin is changed, and the screen returns to LOCAL.

ORIGIN SETUP
0.0 - - - -

Origin position (length)

Origin position (width)

3 Press the key.

- When you press , the screen returns to Step 2.
- When you press the key, the screen returns to LOCAL.

MEDIA RESIDUAL PRINT
 <ENT>

4 Press the key.

- The remaining amount of a medium starts to be printed.
- When the printing has been completed, the screen returns to LOCAL.



- When the remaining amount of a medium has been printed with the origin changed, the origin set here is effective even when subsequent data are printed.



White Ink Maintenance Function

If SS21 white ink is left unused for a while, the color may become uneven by clogging of the nozzle or settling of pigment.

If the color does not improve by the head cleaning (☞ P.2-39), use this maintenance function. (This function is valid when the firmware Ver.2.10 or later is installed and SS21 white ink is filled.)

White ink maintenance function has three levels of maintenance.
Select the maintenance level depending on the condition.

LEVEL1	Performs maintenance in the following order: (1) Performs the automatic nozzle cleaning function. *1 (2) Performs cleaning. *2
LEVEL2	Performs maintenance in the following order: (1) Performs the automatic nozzle cleaning function. *1 (2) Fills the white ink. (3) Performs cleaning. *2
LEVEL3	Performs maintenance in the following order: (1) Performs the automatic nozzle cleaning function. *1 (2) Discharges the white ink remaining in the head or in the tube. (3) Fills the white ink. (4) Performs cleaning. *2

*1. The operation is the same as the CUSTODY WASH of ST. MAINTENANCE. (Leaving time: three minutes)

*2. The operation equivalent of "Hard cleaning" of the head cleaning is performed on each color. (☞ P.2-39).

Important!

- According to the level changing from 1 to 3, the amount of consumption becomes more. Use Level 2 and 3 when the status is not improved even if you perform Level 1 maintenance.
- When the machine is left unused for a long time, it is recommended to perform LEVEL1 of this function about every other week.
- The other cautions of this function or the white ink are included in the pack of the cartridge. Read it carefully before use.

1 Press the **MODE CHANGE** key in LOCAL to select the printing mode.

<LOCAL . 1> [# 0 1]
WIDTH : * * * * mm

2 Select [WHITE MAINT.] of the maintenance menu.

- (1) Press the **FUNCTION** key.
- (2) Press **▲** **▼** to select [MAINTENANCE] and press the **ENTER** key.
- (3) Press **▲** **▼** to select [WHITE MAINT.].

3 Press the **ENTER** key.

WHITE MAINT.
SELECT : LEVEL **1**

4 Select the maintenance level by pressing the **▲** **▼**.

- Set value : LEVEL1 to LEVEL3
- This describes the operation when LEVEL3 is set.

WHITE MAINT.
SELECT : LEVEL **3**

5 Press the **ENTER** key.

SHAKE WHITE INK
CARTRIDGES : **e n t**

6 Slowly shake the removed white ink cartridge more than twenty times right and left.

- To prevent ink from leaking when you shake the cartridge, wear gloves and firmly cover the A part of the upper surface of the cartridge and the B part of the bottom surface of the cartridge with paper towels. Then, shake it more than twenty times right and left so that ink flows inside the cartridge.



- If you shake it too strong, the pack inside may be damaged and it may cause ink leakage. Therefore, perform this carefully.
- If the remaining amount of ink is less, ink in the cartridge cannot be beaten enough. Tilt the cartridge until it becomes vertical.

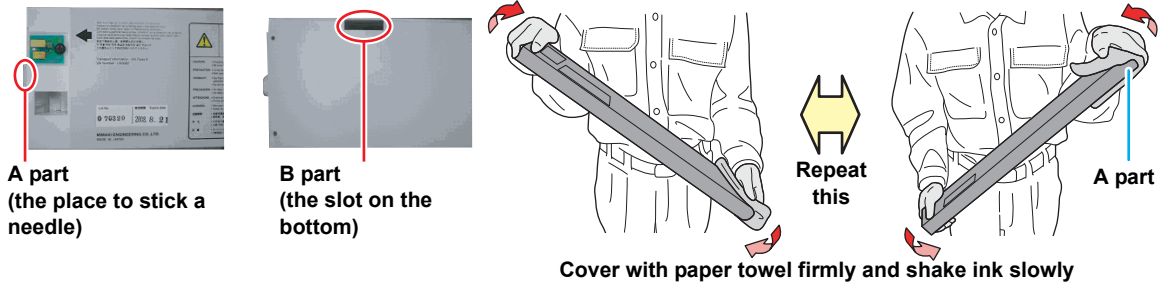

7 Set the white ink cartridge, and press the **ENTER key.**

- Nozzle cleaning starts.
- The operation after nozzle cleaning varies depending on the LEVEL set on the Step 4.
- LEVEL1 : Go to the Step 11.
- LEVEL2 : Go to the Step 10.
- LEVEL3 : Go to the Step 8.

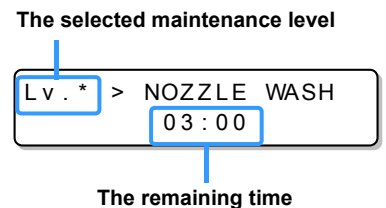

8 Remove the white ink cartridge.

- When the white ink cartridge is removed, the white ink remaining in the machine is discharged.
- After discharging, the screen shown on the right appears.

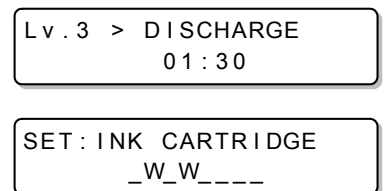

9 Set the white ink cartridge.

10 White ink filling starts.

- Filling time of LEVEL2 is different from LEVEL3. (When LEVEL2 is selected, filling time becomes shorter.)



11 Perform cleaning.

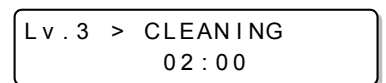

If a Waste Ink Tank Confirmation Message Appears

Ink used in head cleaning, etc. is stored in the waste ink tank on the lower right side of the machine. This machine counts the accumulated amount of discharged ink. When that reaches a specified amount, the machine displays a confirmation message. **(When this message is displayed, consider the replacement of the waste ink tank.)**

If a Message Is Displayed, for Example, When the Machine Is Supplied with Ink

When functions that use the waste ink tank, such as ink-supplying, head cleaning, and PUMP tube washing, are performed, a message that requests you to confirm the state of the waste ink tank may be displayed, depending on the state of the tank.

- **When the waste ink tank is almost full:**

The message on the right is displayed.

```
* Check waste ink *  
Continue< >Exchange
```

1 Check the state of the waste ink tank.

When the waste ink tank is almost full:

- (1) Replace the waste ink tank with another. (☞ P.6-40)
- (2) Press the **ENTER** key to select "Exchange". (The amount of discharged ink is reset.)

When the waste ink tank still has a capacity for waste ink:

- (1) Press **◀** to select "Continue". (The amount of discharged ink is not reset.)
 - In this case, returning to LOCAL will display the message of P. 6-38 "Confirmation Message in LOCAL".

- **When the waste ink tank is completely full:**

The message on the right is displayed.

```
* Check waste ink *  
Exchange :ent
```

1 Replace the waste ink tank with another (☞ P.6-40) and press the **ENTER** key.

- The amount of discharged ink is reset.

Important!

- When you have selected "Exchange" for "almost full" or "completely full" in the above operation, make sure to replace the waste ink tank. (☞ P.6-40) When you use the machine without replacing the waste ink tank, waste ink may overflow from the tank before a confirmation message is displayed.
- This machine does not count the accumulated amount of waste ink discharged when the ST.MAINTENANCE (NOZZLE WASH, PUMP TUBE WASH, and COSTODY WASH) are performed. Before performing these functions, make sure to check the state of the waste ink tank.

Confirmation Message in LOCAL

The message on the right is displayed.

```
<LOCAL.1> [#01]  
Check waste ink<MNT>
```

1 Check the state of the waste ink tank and replace it with another as necessary. (☞ P.6-40)

When You Do Not Want the Confirmation Message of the Waste Ink Tank to Be Displayed

You can configure the setting so that the confirmation message of the waste ink tank is not displayed.

1

Press the **MODE CHANGE** key in LOCAL to select the printing mode.

```
<LOCAL . 1>      [ #01 ]
                WIDTH: * * * * mm
```

2

Select [Waste Ink Warning] of the machine setting menu.

- (1) Press the **FUNCTION** key.
- (2) Press **▲** **▼** to select [MACHINE SETUP] and press the **ENTER** key.
- (3) Press **▲** **▼** to select [Waste Ink Warning].
- (4) Press the **ENTER** key.

3

Press **▲** **▼** to select OFF.

```
WasteInkWarning
SETUP           : OFF
```

4

Press the **ENTER** key.

```
MACHINE SETUP
WasteInkWarning<ent>
```

5

Press the **END** key several times to end the setting.

Important!

- When you set Waste ink warning to "OFF", the confirmation message is not displayed. Make sure to visually check the amount of ink remaining in the waste ink tank.

Replacing the Waste Ink Tank with Another

When the message on the right has been displayed, check the state of the waste ink tank immediately and replace the tank as necessary.

<LOCAL . 1> [# 0 1]
Check waste ink<MNT>

1 Remove the waste ink tank guard.

- (1) Lift the waste ink tank guard and unlock it.
- (2) Open the waste ink tank guard to your side.

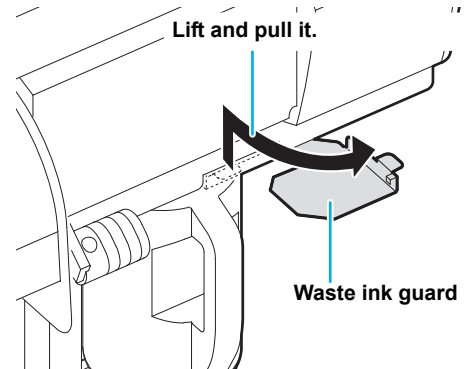

2 Hold the grip of the waste ink tank and remove the tank by pulling it to your side.

- Attach the cap to the removed waste ink tank.

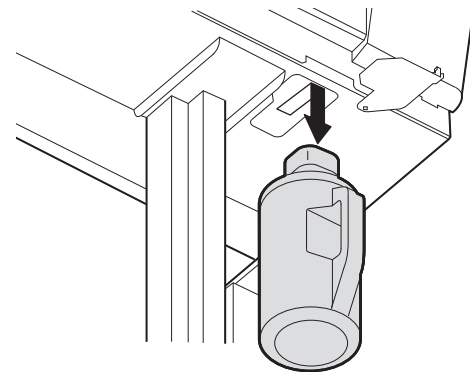
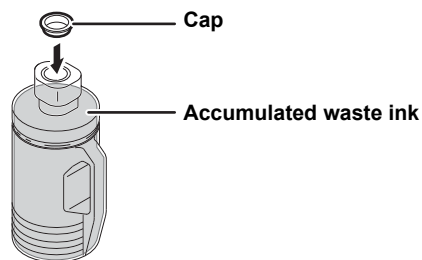

3 Replace the waste ink tank with another.

- (1) Prepare a new waste ink tank (SPC-0117).
- (2) Hold the grip of the waste ink tank and insert the tank.

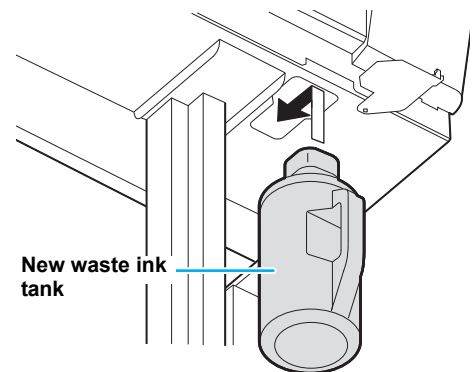

4 Close the waste ink tank guard.

- Align the protrusion of the waste ink tank guard with the hole of the main body and lock the tank.

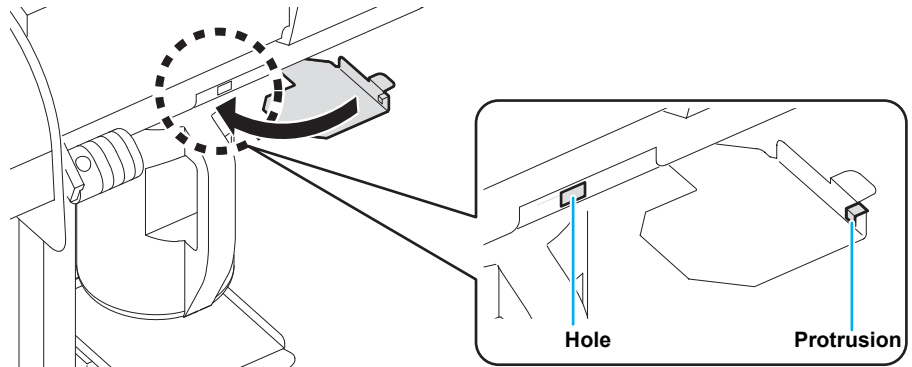

5 Press the **MODE CHANGE** key in LOCAL to select the printing mode.

```
<LOCAL . 1>      [#01]
                WIDTH: ****mm
```

6 Select [Ink Tank Replace] of the maintenance menu.

- (1) Press the **FUNCTION** key.
- (2) Press **▲** **▼** to select [MAINTENANCE] and press the **ENTER** key.
- (3) Press **▲** **▼** to select [Ink Tank Replace].

7 Press the **ENTER** key.

```
InkTankReplac
EXCHANGE      :ent
```

8 Press the **ENTER** key.

- The amount of discharged ink controlled by this machine is reset, and the confirmation message is canceled.

9 Press the **END** key several times to end the setting.

Changing the ink

Ink type or the color used can be changed.



- To change the ink set such as changing from “4-color model” to “6-color model” or “6-color model”, the machine must be worked by our service engineer. Contact our service office or the distributor in your region.

Change the ink type

To change the ink type used such as changing from ES3 ink to SS21 ink, work as follows.

Change the ink color

To change the ink color used such as changing from “6-colors” to “6-colors + white” of SS21 ink, work as follows.

“Discharge” the remaining ink in the machine, and “Wash” the head or the tube.

See P.6-19 “DISCHARGE & WASH”.

Fill ink.

See P.6-18 “FILL UP INK”.

Important!

- Note for changing ink type**

Changeable ink type is limited by the type of ink used. See the table on the right.

		Ink type to be changed	
		Eco-PA1	SS21/ES3
Ink type used	Eco-PA1	Changeable	Contact our service office or the distributor in your region.
	SS21/ES3	Not changeable	Changeable (However, when you wish to change to silver ink or white ink of ES3, the work by our service staff is required.)

- When washing, use eight special cleaning solution cartridges (sold separately).**

Wash with the proper cleaning solution cartridge for the used ink type.

Ink Type	Cleaning Solution Type
Solvent ink (SS21/ES3)	MILD SOLVENT Cleaning Solution Cartridge (SPC-0294)
Aqueous pigment ink (Eco-PA1)	Aqueous cleaning solution cartridge (SPC-0259)

Replacing the Cutter Blade

The medium cutter blade is consumable. When the cutter blade gets dull, replace it with a new one (SPA-0107).



- The blade is sharp. Be careful not to hurt yourself or anyone else.
- Store the cutter blade in a place that is out of the reach of children. In addition, dispose of used cutter blades according to regional laws and regulations.



- When replacing the cutter blade, it is recommended to place a sheet of paper under the cutter blade. This will help pick up the cutter blade if it drops.

1	Press the MODE CHANGE key in LOCAL to select cutting mode.	<LOCAL . C > [#01] CUT1 (30 / 60 / 0.30)
2	Press the FUNCTION key.	FUNCTION SETUP <ENT> C
3	Press ▼ ▲ to select [MAINTENANCE].	FUNCTION MAINTENANCE <ENT> C
4	Press the ENTER key.	MAINTENANCE MARK SENSOR <ent>
5	Press ▼ ▲ to select [TOOL REPLACE].	MAINTENANCE TOOL REPLACE <ent>
6	Press the ENTER key.	TOOL REPLACE ACTION :ent
7	Press the ENTER key. • The cutter unit moves to the left end of the machine.	



8

Replace the cutter unit by the carriage.

- Now the cutter unit can be moved manually. Move the cutter unit to the position where you can assure easy access, and then replace the blade edge.

- (1) Loosen the screw of the cutter unit.
- (2) Remove the cutter unit.
- (3) Mount a new cutter unit.
- (4) Fasten the screw of the cutter unit to secure the cutter unit.

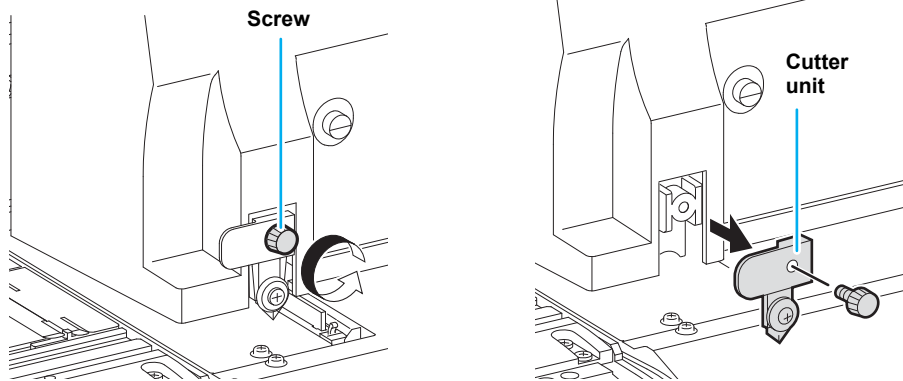

9

When replacement is finished, press the **ENTER** key.

- The screen returns to LOCAL.



Replacing the Pinch Rollers

Replace the pinch roller when it is worn or dirty.
(SPA-0166: Set of four pinch rollers / SPA-0167: Set of three pinch rollers)

1

Remove the O-ring, pinch roller axis, and pinch roller.

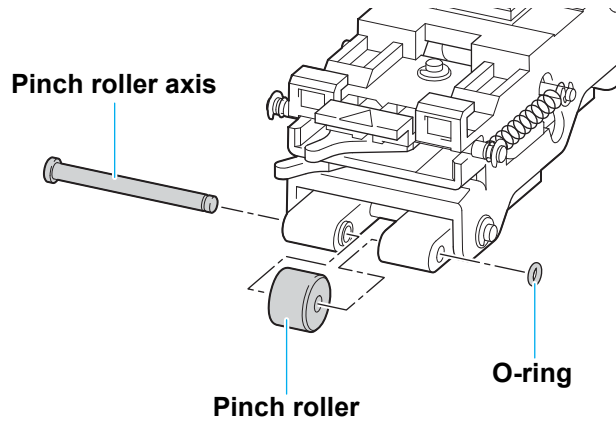

2

Attach a new pinch roller, and reattach the pinch roller axis and O-ring to their original positions.



6

Maintenance

Replacing a Cutter Blade Not Included in the Accessories

This section describes how to replace the cutter holder (Swivel cutter holder : SPA-0090) and the cutter (Swivel blade : SPB-0030) that are sold separately.

1

Rotate the cap from which a blade comes out and remove the cutter.

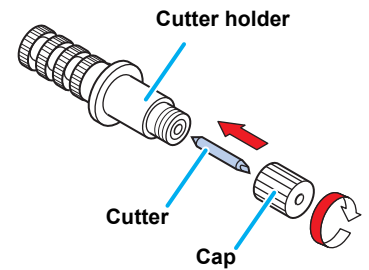

2

Replace the cutter with a new one, using tweezers.

3

Adjust the length of the cutter blade that comes out from the cap.

- When you rotate the adjustment knob in the direction of an arrow, a cutter blade emerges. (0.5 mm per rotation)

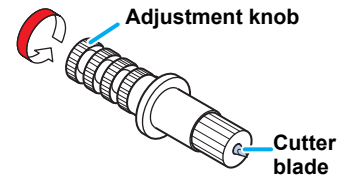

Chapter 7

Troubleshooting



This chapter

describes the corrective measures to be taken for a phenomenon suspected to be trouble and the procedures to clear the error number displayed on the LCD.

Troubleshooting	7-2
Image Quality Is Poor	7-4
Nozzle Is Clogged	7-4
Ink Cartridge Warning Appears	7-5
Warning/Error Messages	7-7
Warning Messages	7-7
Error Messages	7-10

Troubleshooting

Take the appropriate actions as described below before taking the trouble as a failure. If the problem is still not solved after troubleshooting, contact your distributor or our service office.

Failure phenomenon	Cause	Solution
Power does not turn ON.	The power cable of the machine is not connected securely.	Securely connect the power cable of the machine to the outlet.
	The main switch is not ON.	Turn ON the main switch.
	The power switch located on the front of machine is not ON.	Turn ON the power switch on the front of the machine.
Printing/cutting (printing with a pen) does not start.	The interface cable is not connected securely.	Securely connect the interface cable.
	The interface cable is not correct.	Use a USB2.0 Hi-Speed-compliant cable.
	The message indicating that the ink has run out is displayed.	Replace the ink cartridge with a new one.
	The host computer setting (machine model, etc.) is wrong.	Check the host computer setting.
Medium gets jammed. Medium is soiled.	The USB driver is not installed.	Install the USB driver included with the machine.
	A medium other than those recommended by MIMAKI is used.	Use the recommended medium.
	Medium is curled.	Avoid using a medium with curls.
	The end of the medium is bent.	Avoid using any medium with bent ends.
[HEAT] or [CONSTANT] LED does not light up.	The medium is hanging down along the platen.	Use a take-up device or re-load the medium on the machine.
	The power to the machine is not ON.	Turn ON the power to the machine.
An error occurs in the machine when the host computer sends data to the machine.	The heater temperature setting is not effective.	Set the heater temperature higher than room temperature.
	Command settings are wrong.	Use the application included with the machine.
Cutting produces a perforation rather than a clean cut.	Machine model setting is wrong.	Correct the machine model setting to [CJV30] on the application software.
	Screw for the tool holder is loose.	Tighten up the screw.
	The cutter blade protrudes excessively.	Adjust the protrusion of the blade properly.
	The tool condition is set to [HALF].	Set the tool condition to [CUT1] to [CUT3].
Slippage of medium arises in cutting.	The blade is chipped or worn out.	Replace the blade with a new one.
	The blade does not rotate smoothly.	Replace the holder with a new one.
	The pinch rollers and grid rollers fail to securely retain the medium in position.	Check the position of the pinch rollers and grid roller and adjust them so that they securely retain the medium in position. Increase the number of pinch rollers.
The pinch roller pressure is not properly selected.	The pinch roller pressure is not properly selected.	Select the proper pinch roller pressure. (☞ P.4-2)
	There is a slack in the roll medium so the medium fed meanders or skews.	Remove the slack in the roll medium and straighten the right and left end faces of the roll when loading the roll medium on the machine. Then, start feeding the medium.











Failure phenomenon	Cause	Solution
Slippage of medium arises in cutting.	The medium was bent and came off the backing paper and thus there are air bubbles between the medium and the backing paper.	When a long leaf medium is to be cut, take care not to bend the medium while feeding or cutting it and do not put any extra load on the medium.
		When a long leaf medium is to be cut, provide a sufficient space for working in the direction of medium feeding. Front: 1.5 m or more Rear: 1.5 m or more
	The setting direction of the medium and the direction specified on the data do not agree with each other.	Correct the medium setting or data setting.
	The medium comes in contact with the floor surface.	Decrease the cutting speed (SPEED) to reduce the load on the medium when it comes in contact with the floor surface.
	The side margins of the medium beside the pinch rollers are not enough.	Provide a side margin of 20 mm or more on each side of the medium beside the pinch rollers.
	The setting of offset X and offset Y of "Setting Register Mark Detection" is not correct.	Correct the offset value in concert with misalignment. (☞ P.4-11)
The tool is dragged during operation.	The medium is warped.	Load the medium on the machine so that the medium is not warped.
An unexpected cutter imprint remains on the medium.	The tool does not move up/down successfully.	Turn the power OFF and try to lift/lower the tool holder by hand. If the tool holder does not move up but remains in the lower position, contact your distributor or our service office.
	An extremely thick medium is used.	Use a medium meeting the specifications.
Some parts remain uncut.	Low pressure on the cutter blade.	Increase the value of "ADJ-PRS OFFSET". (☞ P.4-36)
		Increase the cutter pressure and perform test cutting again. (☞ P.2-43)
		Set the over cutting. (☞ P.4-36)
Register mark cannot be detected.	The position of the register mark sensor and the light pointer is not the same.	Adjust the position of the light pointer. (☞ P.4-20)
	The sensitivity of the register mark sensor is low.	Adjust the sensitivity of the register mark sensor. (☞ P.4-21)
There is a part remaining uncut when cutting medium.	Both ends of the medium stays away from the position of pinch rollers located at both ends.	Set the pinch roller of both ends so that they are within the range of 10cm from medium left end and 2cm from medium right end. (☞ P.2-17)



7

Image Quality Is Poor

This section describes the corrective actions to be taken in case the image quality is not satisfactory. Take appropriate measures to remedy the problems with image quality. If the remedy does not work, contact your distributor or our service office.

Failure phenomenon	Solution
White lines/blur/dark stripes (in the direction the heads travel)	<ol style="list-style-type: none"> (1) Execute head cleaning.  P.2-39 (2) Perform maintenance of the inside of the station.  P.6-5 (3) Execute the [Media correction] function.  P.3-8 (4) If any pieces of paper or dust is attached on the medium holder or other paths of the head, remove it.
Characters are double or triple printed in the media feed direction.	<ol style="list-style-type: none"> (1) Execute the [Media correction] function.  P.3-8
Disagreement in print positions between outward trip and homeward trip.	<ol style="list-style-type: none"> (1) Execute the [Dot position correction] function.  P.3-10
Ink drops falling on the medium during printing.	<ol style="list-style-type: none"> (1) Execute the wiper cleaning.  P.6-6 (2) Execute the ink cap cleaning.  P.6-6 (3) Execute the head cleaning [Normal].  P.2-39 (4) When the phenomenon is not improved, set the regular wiping operation.  P.6-28

Nozzle Is Clogged

When nozzle clogging is not dissolved even after cleaning the head referring to P.2-39, make sure of the following operations.

- **Fill ink by executing the operations of P.6-18.**
- **Following the procedures described in P.6-19, perform DISCHARGE & WASH.**



Ink Cartridge Warning Appears

If trouble with an ink cartridge is detected, a warning message appears. Printing, cleaning, and all the other operations that use ink become disabled if warning occurs. In this case, replace the ink cartridge immediately.

Important!

- Once cartridge trouble is displayed, do not leave the ink cartridge for a long time without replacing it; otherwise, the machine will lose the nozzle clogging prevention function. If nozzles are clogged, the machine must be repaired by our service engineer.

Displaying the Description of Ink Cartridge Trouble

You can check the details of the cartridge error with the following operations. (☞ P.7-6)

1

Press the **ENTER** key in LOCAL.

SS21 mr 1	MMCCYYKK
REMA IN	34567899

2

Press the **FUNCTION** key.

NON-ORIGINAL INK
---C---

Indicates that the cartridge of cyan (C) has some abnormality.

- When two or more cartridge troubles occur, warnings can be displayed in turn by pressing **▲** **▼**.
- Press **FUNCTION** or **END** to return to the display of the remaining amount of ink.

Messages and Solutions

Message	Cause	Solution
INK NEAR END MMCC - - - -	The ink of the ink cartridge has been nearly used up.	Replace the cartridge generating the warning with a new one.
INK END - - - - YYKK	The ink of the ink cartridge has been completely used up.	Replace the cartridge generating the warning with a new one.
NON-ORIGINAL INK - - - - YYKK	The ink cartridge is not our genuine product.	Replace the cartridge generating the warning with our genuine product.
WRONG INK IC - - - - YYKK	The IC chip of the ink cartridge cannot be read normally.	Remove the cartridge generating the warning once and install it again. If the same warning message still appears, contact our service office or the distributor in your region.
Kind of INK - - - - - - - -	The ink of the ink cartridge is different in type from the ink currently supplied.	Check the ink type of the cartridge generating the warning.
Color of INK - - - - - - - -	The ink of the ink cartridge is different in color from the ink currently supplied.	Check the ink color of the cartridge generating the warning.
WRONG CARTRIDGE - - - - - - - -	There is trouble with an installed ink cartridge.	Check the cartridge generating the warning.
NO CARTRIDGE - - - - - - - -	An ink cartridge has not been installed in the slot.	Install an appropriate cartridge in the slot generating the warning.
Expiration - - - - - - - -	The specified expiration date of an ink cartridge has passed.	Replace the cartridge generating the warning with a new one. The cartridge may be used until one month after the specified expiration date.
Expiration:1MONTH - - - - - - - -	The expiration date of an ink cartridge has elapsed (one month has passed after the specified expiration date).	The red LED blinks. Replace the cartridge generating the warning with a new one. The cartridge may be used until two months after the specified expiration date.
Expiration:2MONTH - - - - - - - -	The expiration date of an ink cartridge has elapsed (two months have passed after the specified expiration date).	Replace the cartridge generating the warning with a new one.
INK REMAIN ZERO - - - - - - - -	The remaining amount of the ink in an ink cartridge is zero.	Replace the cartridge generating the warning with a new one.
Check the "W" nozzle condition. <ENT>	When SS 21 white ink is used, the message of prompting you to perform test printing is displayed for keeping the nozzle status be normal.	Perform "WHITE CHK." of test printing. (☞ P.2-37)
PERFORM SPOT COLOR MAINTENANCE? <ENT>	When silver and white ink of ES3 ink are used, the message of prompting you to perform special color maintenance for preventing color heterogeneity due to settling down of pigment is displayed.	Perform spot color maintenance.



Warning/Error Messages

If some trouble occurs, the buzzer sounds and the display shows a corresponding error message. Take appropriate measures to remedy the displayed error.

Warning Messages

Message	Cause	Solution
** NO MEDIA **	Medium is not set.	Set the medium.
! EXCHANGE BATTERY	The end of the life of the internal clock battery is detected.	Contact our service office or the distributor in your region.
<LOCAL . 1> [# 0 1] Repl a c e a W I P E R < M N T >	Time to replace the wiper in the capping station with a new one has come. (The wiping count has reached the specified value.)	Replace the wiper with a new one. (☞ P.6-8)
<LOCAL . 1> [# 0 1] ! D o T E S T P R I N T	When the power supply has been kept turning OFF for 72 hours or longer, sleep refresh or cleaning was not performed.	Perform the test printing and check the nozzle status. If the power supply has been kept turning OFF for a long time, the sleep operation must be performed. (☞ P.6-23)
P R E P R T P O S T B R E A K * * ° C * * ° C	A heater is disconnected. (This example shows that the preheater is disconnected.)	Contact our service office or the distributor in your region.
P R E P R T P O S T T H E R M * * ° C * * ° C	The thermistor of a heater is defective. (This example shows that the thermistor of preheater is defective.)	
<LOCAL . 1> [# 0 1] N E A R E N D M M C C - - - -	Ink for one supply path has been nearly used up.	Replace the cartridge for the supply path corresponding to the indicated color. You can print without replacing the cartridge (until "No ink" is displayed). However, the machine returns to LOCAL each time when the printing of one file is completed.
* R E M O T E . 1 * [# 0 1] N E A R E N D M M C C - - - -		
<LOCAL . 1> [# 0 1] I N K E N D - - - - Y Y K K	Ink for one supply path has been completely used up.	Replace the cartridge for the supply path corresponding to the indicated color.
* R E M O T E . 1 * [# 0 1] I N K E N D - - - - Y Y K K		
<LOCAL . 1> [# 0 1] ! C A R T R I D G E - - - - Y Y K K	Ink for one supply path is not set. Or improper ink is set.	Replace or set the cartridge for the supply path corresponding to the indicated color. Refer to P. 7-5 "Ink Cartridge Warning Appears" to check the details of the failure, and then fix the problem following the applicable procedure.
* R E M O T E . 1 * [# 0 1] ! C A R T R I D G E - - - - Y Y K K		
<LOCAL . 1> [# 0 1] R E I N S E R T C A R T R I D G E	Ink near end was detected right after the cartridge with much remaining amount of ink has been inserted.	Pull out the inserted cartridge and insert it again. If the message will be displayed again, contact a distributor in your district or our office to call for service.
<LOCAL . 1> ! C A R [# 0 1]	There is a problem with the installed ink cartridges.	Check the warning details in the guidance function. (☞ P.7-5)
* R E M O T E . 1 * ! C A R [# 0 1]		



7

Troubleshooting

Message	Cause	Solution
<LOCAL.1>!WSH [#01] *REMOTE.1*!WSH [#01]	There are the following problems with the cleaning solution: The cleaning solution is not set. Something other than the cleaning solution is set. The cleaning solution is ended.	Replace the cleaning solution.
<LOCAL.1>!RTN [#01] *REMOTE.1*!RTN [#01]	As the connection unit is not connected to the print head, regular operations cannot be executed.	Start the origin setting in the print mode, and switch the connection unit, or execute the appropriate regular operations manually.
<LOCAL.1>!TNK [#01] *REMOTE.1*!TNK [#01] <LOCAL.1> [#01] Check waste ink<MNT>	The waste ink tank is nearly full.	Replace the waste ink tank, and then execute [MAINTENANCE]-[Ink Tank Replace]. (P.6-40)
<LOCAL.1> [#01] !Wash Liquid END	The cleaning liquid cartridge is empty.	Replace the cleaning solution cartridge with a new one.
<LOCAL.1> [#01] !washLiquidCart.NON	The cleaning liquid cartridge has not been installed.	Install the cleaning solution cartridge.
<LOCAL.1> [#01] !WRONG WASH CART.	There is trouble with the cleaning liquid cartridge.	Install the cleaning solution cartridge.
** Washing liquid **	Cleaning solution has not been supplied.	Supply the cleaning solution. Execute [MAINTENANCE]- [HD.MAINTENANCE]-[FILL UP INK]. (P.6-18)
** OFFSCALE **	The cutting data exceeds the effective cutting area. Or the machine has stopped after cutting the medium up to its end normally.	Use a larger medium, decrease the amount of data, or execute the divided cutting function. This warning may occur depending on the set value of the P/C origin offset (P.4-32).
** END COPY **	The plotter has terminated copying after completion of one sheet copying, since the data received contains the origin updating command.	The plural sheets cutting function is disabled. To perform plural sheets cutting, change the setting back to enable the function on the host computer.
** DIVISION ** 5s	The machine has finished the cutting corresponding to a division of the data that exceeds the medium width, using the division cut function, and is now waiting for the receipt of the next data.	If the machine does not receive any data from the host computer within ten seconds, it will recognize that the data has ended. Then, the machine will perform the frame cutting and mark cutting and enter LOCAL.
** END DIVISION **	This message appears in any of the following cases: The medium width is 1 cm or less. The sample cutting data exceeds the medium width. The two-point axis alignment is set to ON. Register marks have already been detected.	Division cut is disabled.



Message	Cause	Solution
COPY SKIP	A register mark cannot be detected during continuous copying. (One pattern is skipped.)	There is no problem if the marks are successfully detected after skipping one pattern. If marks cannot be detected continuously by five patterns or more, [ERROR 36-C MARK DETECT] (P.7-12) is displayed.
MEDIA SKEW <ENT>	Sheet misalignment exceeds the setting length of skew check (P.4-14).	Set the sheet again and press the ENTER key.
PAUSE REM/END	The plotter is holding the register mark detecting operation, since the REMOTE key has been pressed during the detection process.	Press the REMOTE key to resume the mark detection. Or press the END key to end the operation.
MEDIA EXCHANGE	The machine is waiting for the medium to be replaced during continuous copying in the leaf media mode.	Replace the leaf sheet (cut sheet) with a new one, and resume continuous copying.
MEDIA END REM/END	End of the medium is detected while detecting a register mark or cutting roll medium.	Cutting cannot be continued, since roll medium has ended. Press the END key and replace it with new medium.
	The medium is lifted.	Fix the lifting of the sheet and press the REMOTE key to resume cutting.
	The back of the machine is exposed to intense light.	Turn the machine around so as not to exposed it to the light, and press the REMOTE key to resume cutting.



7

Error Messages

When an error message is displayed, eliminate the error according to the chart below.
If the same error message appears again, contact your distributor or our service office.

Error messages	Cause	Solution
***** ERROR 01 ***** MAIN ROM	An error occurred in the circuit board system. (ROM)	Turn OFF the power to the machine and turn it ON again after a while. If the same error message appears again, contact our service office or the distributor in your region.
***** ERROR 02 ***** MAIN RAM	An error occurred in the circuit board system. (RAM)	
***** ERROR 03 ***** POWER +5V	An error occurred in the circuit board system. (Power supply voltage +5 V)	
***** ERROR 03 ***** POWER +24V	An error occurred in the circuit board system. (Power supply voltage +24 V)	
***** ERROR 03 ***** POWER +42V	An error occurred in the circuit board system. (Power supply voltage +42 V)	
***** ERROR 04 ***** F-ROM	An error occurred in the circuit board system. (Parameter ROM)	
***** ERROR 06 ***** SD-RAM	An error occurred in the circuit board system. (SDRAM)	
***** ERROR 07 ***** HEAD (- - - -)	A connection error in the heads was detected. (Abnormal temperature was detected.)	
***** ERROR 07 ***** VOLTAGE (- - - -)	A connection error in the heads was detected. (Abnormal voltage was detected.)	
***** ERROR 08 ***** Linear ENCODER: SENSOR	An error occurred in detecting the linear encoder. (Unable to count)	
***** ERROR 08 ***** Linear ENCODER: DIR.	An error occurred in detecting the linear encoder. (Error in the mounting direction)	
***** ERROR 08 ***** Linear ENCODER: COUNT	An error occurred in detecting the linear encoder. (Read-out count error)	
***** ERROR 09 ***** FPGA ERROR	An error occurred in the circuit board system. (FPGA PDC)	
***** ERROR 09 ***** HDC ERROR (- - - -)	An error occurred in the circuit board system. (FPGA HDC)	
***** ERROR 10 ***** COMMAND ERROR	The machine received some data other than command data.	According to the application, switch the settings for COMMON SETUP>RECEIVED DATA. (☞ P.5-2)
***** ERROR 10-C ***** COMMAND ERROR		Securely connect the interface cable in position. Use an interface cable conforming to the specifications.
***** ERROR 11 ***** PARAMETER ERROR	Any parameter outside the range of acceptable numeric values was received.	Turn OFF the power to the machine and turn it ON again after a while. If the same error message appears again, contact our service office or the distributor in your region.
***** ERROR 11-C ***** PARAMETER ERROR		



Error messages	Cause	Solution
***** ERROR 12 ***** MAINTENANCE COMMAND	Data other than command data has been received.	Turn OFF the power to the machine and turn it ON again after a while. If the same error message appears again, contact our service office or the distributor in your region.
**** ERROR 12-C ***** DEVICE	An improper device control command is issued.	Change the control command to the machine, and then send the data again. Or, turn the power OFF, turn it back ON, and then send the data again. If the same error message appears again, contact our service office or the distributor in your region.
**** ERROR 13-C ***** PM OVER	The receiver buffer exceeds the limit.	Divide the polygonal data and send the divided data.
**** ERROR 15-C ***** AUTO FEED	The machine failed to feed the medium by the length specified by the data.	Load the longer medium, and then try again.
***** ERROR 16 ***** MRL COMMAND	The received data does not follow the command system set with the machine.	Transmit data that is compatible with the command system using the application supported by this machine.
***** ERROR 25 ***** FULL-SPEED	An error occurred in communication between the host computer and this machine due to the USB2.0 connection. (Full-Speed mode connection)	Check that the host PC supports the USB2.0 interface. (Communication can be resumed without changing any setting. However, it is recommended to use the connection in High-speed mode.)
***** ERROR 25 ***** PACKET SIZE OVER	An error occurred in communication between the host computer and this machine due to the USB2.0 connection.	Check that the cable is securely connected. Also, check to see if any error has occurred in the host computer.
***** ERROR 25 ***** USB PROTOCOL		
***** ERROR 25 ***** USB ENVIRONMENT		
***** ERROR 25 ***** USB DATA		
***** ERROR 30 ***** CAN'T OPERATE	Improper operation was conducted on the operation panel.	The bottom row of the display shows the reason by which the operation is disabled. Eliminate the cause of the error, and then continue the operation.
**** ERROR 31-C ***** NO DATA	Multiple cutting cannot be executed because the receiver buffer is empty.	Send the cutting data before executing the No.COPIES.
**** ERROR 32-C ***** DATA TOO BIG	Multiple cutting cannot be executed because the received data is too large.	Refer to the No.COPIES function.
**** ERROR 33-C ***** MEDIA SIZE	The medium length in the medium-feeding direction is too short.	Use a longer medium.
***** ERROR 34 ***** PRINT DATA REMAIN	The function setting has been changed or an unavailable function has been commanded while an unfinished printing job remains in the queue.	Finish printing all the data that has been received by the machine or clear the remaining data, and then try again.
**** ERROR 34-C ***** CUT DATA REMAIN	Improper operation was conducted while cutting is suspended by REMOTE.	Continue cutting until cutting data is completed, or clear the data.



7

Error messages	Cause	Solution
***** ERROR 35-C ***** cutNG WIND	To execute takeup, media cannot be automatically cut.	When TAKEUP TIMING is set on roll media detection, autocut is not executed. If putting priority on autocut, set TAKEUP TIMING "OFF". (P.4-37)
***** ERROR 36-C ***** MARK DETECT	A register mark cannot be detected. (During the mark detection process after detecting the medium)	Confirm the following items: <ul style="list-style-type: none"> • Medium is not curled. • The register mark detection start point is set correctly. (P.4-15) • The register marks are printed in black against a white background. • There is no unnecessary patterns, dust, or dirt between the register marks. • Various settings regarding the register mark are configured appropriately. (P.4-11) If all the above items are OK, contact our service office or the distributor in your region.
***** ERROR 36-C ***** JOG & <ENT> or <END> ***** ERROR 38-C ***** MARK SCALE	A register mark cannot be detected. (During copy cut of the mark) <ul style="list-style-type: none"> • "MARK DETECT" and "JOG & <ENT> or <END>" are displayed alternately. • "MARK SCALE" and "JOG & <ENT> or <END>" are displayed alternately. 	Confirm the following items: <ul style="list-style-type: none"> • When this error occurs, the light pointer stops at the detection starting point. If the position is found improper, move the light pointer to the appropriate position using the JOG keys. Press the ENTER key to make the machine perform detection again. • When using a soft medium or a large medium of which the width exceeds 800 mm, increase the pinch rollers (middle). • When using a soft medium, set the length of each side of the register mark to 8 mm or above. Also, place the mark copies making a clearance of 8 mm between each mark. • Confirm that the register marks are printed in black against a white background. • Confirm that there is no unnecessary patterns, dust, or dirt between the register marks. • Confirm that the various settings regarding the register mark are configured appropriately. P** • When the media press is used, the medium may be lifted. In this case, remove the media press and try again. If all the above items are OK, contact our service office or the distributor in your region.
***** ERROR 37-C ***** MARK ORIGIN	The origin is detected in the area outside of the available printing area by the register mark detecting process.	Place the register mark within the available printing area.
***** ERROR 40 ***** MOTOR ALARM X	An excessive load was applied to the X motor.	Turn OFF the power to the machine and turn it ON again after a while. If the same error message appears again, contact our service office or the distributor in your region.
***** ERROR 41 ***** MOTOR ALARM Y	An excessive load was applied to the Y motor.	
***** ERROR 42 ***** X OVER CURRENT	An error due to an excessive current of the X motor was detected.	
***** ERROR 43 ***** Y OVER CURRENT	An error due to an excessive current of the Y motor was detected.	
***** ERROR 45 ***** CAPPING: PARAMETER	An error occurred in the capping control. (Improper parameter adjustment value)	
***** ERROR 46 ***** WIPER	An error occurred in the wiper control.	



Error messages	Cause	Solution
***** ERROR 50 ***** MEDIA WIDTH SENSOR	Paper could not be detected.	Confirm the position of the medium setting and the pinch roller and then perform the medium detection again. (☞ P.2-25)
***** ERROR 51 ***** Y-ORIGIN	Y-origin could not be detected.	Turn OFF the power to the machine and turn it ON again after a while. If the same error message appears again, contact our service office or the distributor in your region.
**** ERROR 120 **** ROOM TEMP LOW (XX °C)	The room temperature is out of the usable temperature range (too low).	Adjust the room temperature of the installation place. (☞ P.3-35)
**** ERROR 121 **** ROOM TEMP HIGH (XX °C)	The room temperature is out of the usable temperature range (too high).	
**** ERROR 144 **** CARTRIDGE SET!	There is a slot where no cartridge has been inserted.	The empty slot may be dried to the degree that it cannot use ink. To avoid this trouble, set a cartridge in the empty slot.
**** ERROR 170 **** CUTTER LOCK	Since the cutter head could not be fixed at the waiting position, the coupler switching was disabled.	Turn OFF the power supply and wait for a while. Then turn ON the power. If this message is displayed again, contact our service office or selling office.
**** ERROR 170 **** PRINT HEAD LOCK	Since the print head could not be fixed at the waiting position, the coupler switching was disabled.	
**** ERROR 180 **** CUTTER JOINT	The cutter unit and the coupler are disconnected during operation.	
**** ERROR 181 **** PR POSITION	Paper could not be detected. The pinch roller positions are not appropriate.	Set the pinch rollers in the correct positions. If the same error message appears again, contact your distributor or our service office.
**** ERROR 200 **** HEAD MEMORY (- - -)	An error occurred on the head unit memory.	Turn OFF the power to the machine and turn it ON again after a while. If the same error message appears again, contact our service office or the distributor in your region.
**** ERROR 202 **** DVEICE CONSTRUCTION	The head is not connected. An error occurred on the head slider board. The head is not MIMAKI genuine.	
**** ERROR 203 **** SDRAM SIZE	An SD-RAM of the size required for the machine has not been equipped.	Turn OFF the power to the machine and turn it ON again after a while. If the same error message appears again, contact our service office or the distributor in your region. (When a usable SD-RAM is available, the machine can be started as is. However, the printing speed may be slow depending on the resolution.)
**** ERROR 205 **** 42V HEAD Voltage	An abnormal voltage of head was detected.	Turn OFF the power to the machine and turn it ON again after a while. If the same error message appears again, contact our service office or the distributor in your region.
**** ERROR 206 **** MAIN PCB	An error occurred on the main PCB.	
**** ERROR 208 **** CHECK MAIN PCB ID XX	Model ID of main PCB is different. (XX is ID code.)	
**** ERROR 207 **** XXXXXXXXXX	An error is detected on the waveform printed on the lower line of the display.	
**** ERROR 211 **** Heater TEMP (- - / - - / - -)	An abnormal temperature of the media heater was detected.	



7

Error messages	Cause	Solution
**** ERROR 211 **** HeadWARM.TEMP.(- - - -)	An abnormal temperature of the head heater was detected.	Turn OFF the power to the machine and turn it ON again after a while. If the same error message appears again, contact our service office or the distributor in your region.
**** ERROR 250 **** Y COORDINATES	An error was detected during scanning operation.	
**** ERROR 251 **** SYSTEM ERROR	A system error occurred.	



Chapter 8

Appendix



This chapter

contains the lists of the specifications and functions of this machine.

Main Body Specifications	8-2
Printer Section Specifications	8-2
Cutter Section Specifications	8-2
Common Specifications	8-4
Ink Specifications	8-5
Warning Labels	8-6
Inquiry Sheet	8-8
Function Flowchart	8-9

Main Body Specifications

Printer Section Specifications

Item		CJV30-60	CJV30-100	CJV30-130	CJV30-160
Printing head	Method	Drop-on-demand piezoelectric print heads			
	Specification	One head			
Printing mode (scanning x feeding)		720 x 540 dpi / 540 or 720 or 1440 x 720 dpi / 540 x 900 dpi / 540 or 720 x 1,080 dpi / 720 x 1,440 dpi / 1440 x 1,440 dpi			
Usable inks	Dedicated solvent ink.	Either ES3 ink or SS21 ink			
	Dedicated aqueous ink.	Eco-PA1 ink: 4 colors (Y,M,C,K) 6 colors (Y,M,C,K,Lc,Lm) 7 colors (Y,M,C,K,Lc,Lm,Lk)			
Ink supply		Supplied from ink cartridges through tubes Ink cartridge replacement method: Only when four colors are used: Supplied by toggle switchover with two cartridges per color			
Amount of supplied ink		When eight colors are used: White and silver One 220-cc cartridge for each color Other colors One 440-cc cartridge for each color When six colors are used: One 440-cc cartridge for each color, 440 cc per color (two cartridges (880 cc in total) only for each of magenta and cyan) When six colors + white color are used: White Two 220-cc cartridges, 440 cc per color Other colors One 440-cc cartridge for each color, 440 cc per color When four colors are used: Two 440-cc cartridges for each color, 880 cc per color			
Usable media		Tarpaulin / FF(Flexible Face) / Polyvinyl chloride film / MS Chloroethene / MS Tarpaulin			
Dead space	Leaf medium	Left and right: Inside the pinch roller detection position (default value) / Front: 40.0 mm / Rear: 98.5 mm			
	Roll medium	Left and right: Inside the pinch roller detection position (default value) / Front: 40.0 mm / Rear: 0.0 mm			
Head height adjustment		2.0 mm / 3.0 mm (from the platen surface) 2-step adjustment			
Waste ink tank		Bottle type (2,000 cc)			
Image memory		SD-RAM 128 MB			
Command		MRL-III (MIMAKI original command)			

Cutter Section Specifications

Item		CJV30-60	CJV30-100	CJV30-130	CJV30-160
Maximum speed ^{*1}		30 cm/s			
Maximum acceleration		1 G			
Cutting pressure		10 to 350 g			
Usable tools		Eccentric cutter / water-based ballpoint pen / oil-based ballpoint pen / Ballpoint pen for handwriting (sold on the market) ^{*2}			
Number of times the cutter responds to a medium		10 times/sec			
Usable media		Polyvinyl chloride sheet (Thickness of 0.25mm or less with laminate ^{*3}) / fluorescent sheet ^{*4} / reflecting sheet ^{*4} (excluding high-intensity reflecting sheets)			
Dead space	Leaf medium	Left and right: Inside the pinch roller detection position (default value) / Front: 40.0 mm / Rear: 98.5 mm			
	Roll medium	Left and right: Inside the pinch roller detection position (default value) / Front: 40.0 mm / Rear: 0.0 mm			
Repetition accuracy ^{*5}		± 0.2 mm (excluding the expansion and contraction due to the temperature of the film)			
Reception buffer memory		SD-RAM 30 MB (20 MB when the sorting function is effective.)			



Item	CJV30-60	CJV30-100	CJV30-130	CJV30-160
Command	MGL- II c2			
Program step	25 μm / 10 μm			

- *1. The maximum speed may be limited, depending on the size of a used medium. In addition, the cutting section does not operate with both speed and acceleration being at the maximum.
- *2. Use one with a diameter of 8 to 9 ϕ whose clamped part has no protrusion or taper. In addition, because the position of the pen point changes, depending on the types of pens, no good image quality can be ensured.
- *3. This conforms with our specified sheet.
- *4. When a blade dedicated for fluorescent sheets (SPB-0007) or a blade dedicated for reflecting sheets (SPB-0006) is used
- *5. For repetition accuracy, see the lower part of this page.

Repetition Accuracy Conditions

State of the Plotter

- Clamping pressure: Strong

State of How a Medium Should Be Set

- The left and right margins of the medium must be 20 mm wide or more.
- The medium on the front side must not be warped or lifted.
- The medium and the backing sheet must not be separated (no air bubbles between them) because of the bend of the medium.
- The medium must be set properly by the medium feeding function.
- When the medium is a roll medium, it must not be wound up loosely. (The surface of both ends of the medium must have no steps.)

Cutting Speed

- 30 cm/s or less (when the attached cutter is used)

Data to Be Cut

- Test pattern for maintenance (ten continuous reciprocating motions in the longitudinal direction)
- The medium and the backing sheet must not be separated (no air bubbles between them) because of the extreme bend of the medium caused while it is cut.



Common Specifications

Item		CJV30-60	CJV30-100	CJV30-130	CJV30-160
Maximum printing/cut width		610 mm	1,020 mm	1,361 mm	1,610 mm
Size of a roll medium	Maximum width	620 mm	1,030 mm	1,371 mm	1,620 mm
	Minimum width	100 mm			
	Thickness	1.0 mm or less			
	Roll outside diameter	φ180 mm or less			
	Roll weight ^{*1}	25 kg or less			
	Roll inside diameter	2 or 3 inches			
	Print side	Roll exterior surface			
	Rolling-up processing	The end of a medium is attached to a paper tube with adhesive tape or weak adhesion.			
Size of a leaf medium	Maximum width	620 mm	1,030 mm	1,371 mm	1,620 mm
	Minimum width	100 mm			
Distance accuracy	Absolute accuracy	The larger of the two: ± 0.3 mm or ± 0.3% of a specified distance			
	Reproducibility	The larger of the two: ± 0.2 mm or ± 0.1% of a specified distance			
Rectangular accuracy		± 0.5 mm / 1,000 mm			
Medium skew		5 mm or less every 10 m			
Medium cutting		Cutting in the Y direction by the blade installed on the cutter head (Cutting accuracy (difference between steps): 0.5 mm or less)			
Paper ejection		Roll take-up device supplied as a standard accessory (Switchover is possible between winding up a roll with its printed surface facing inward and outward.)			
Interface		USB 2.0			
Noise	During standby	58 dB or less (FAST-A: 1 m from the front, rear, left, and right sides, and adsorption fan: low)			
	Continuous operation noise	70 dB or less			
Safety standards to be met		VCCI-Class A, FCC-Class A, UL 60950, CE Marking (EMC Directive, Low Voltage Directive), CB Report, and RoHS Directive			
Power specifications		AC100 to AC120 ± 10%, AC220 to AC240 ± 10%, 50/60 Hz ± 1 Hz, 15A or less			
Power consumption ^{*2}		1,380 W or less			
Installation environment	Allowable temperature	20°C to 35°C			
	Relative humidity	35 to 65% Rh (with no dew condensation)			
	Accuracy-ensuring temperature	20°C to 25°C			
	Temperature gradient	± 10°C/h or less			
	Dust	Equivalent to the normal office level			
Weight		110kg	130kg	145kg	160kg
Outside dimensions	Width	1,524 mm	1,934 mm	2,289 mm	2,538 mm
	Depth	739 mm			
	Height	1,424 mm			

*1. The roll must not sag when its both ends are held.

*2. The main body and the heaters are included.

Ink Specifications

Item		When solvent ink is used	When aqueous-color ink is used
Form		Dedicated ink cartridge	
Color		Black ink cartridge Cyan ink cartridge Magenta ink cartridge Yellow ink cartridge Light cyan ink cartridge Light magenta ink cartridge White ink cartridge *1 Silver ink cartridge *2	Black ink cartridge Cyan ink cartridge Magenta ink cartridge Yellow ink cartridge Light cyan ink cartridge Light magenta ink cartridge Light black ink cartridge *3
Amount of supplied ink		220-cc or 440-cc cartridge	
Shelf life		The period is printed on the ink cartridge. Within three months after opening the package even in the available period.	
Storage temperature	During storage	0 to 25°C (average temperature of a day) • Be sure to keep the ink container in an airtight condition.	10 to 35°C (Average daily temperature) • Be sure to keep a vessel in the airtight condition. • Be sure to keep a vessel in a dry, well-ventilated, cool and dark location.
	During transportation	-20 to 60°C • Avoid a place where the temperature becomes lower than -20°C or higher than 60°C.	0 to 40°C • Avoid the condition lower than -0 °C and higher than 40 °C.

- *1. When SS21W-2 (SPC-0504-W) ink cartridge is used.
When ES3 white ink (SPC-0433-W) ink cartridge is used.
- *2. When ES3 silver ink (SPC-0433-Si) ink cartridge is used.
- *3. When Eco-PA1 ink cartridge is used.











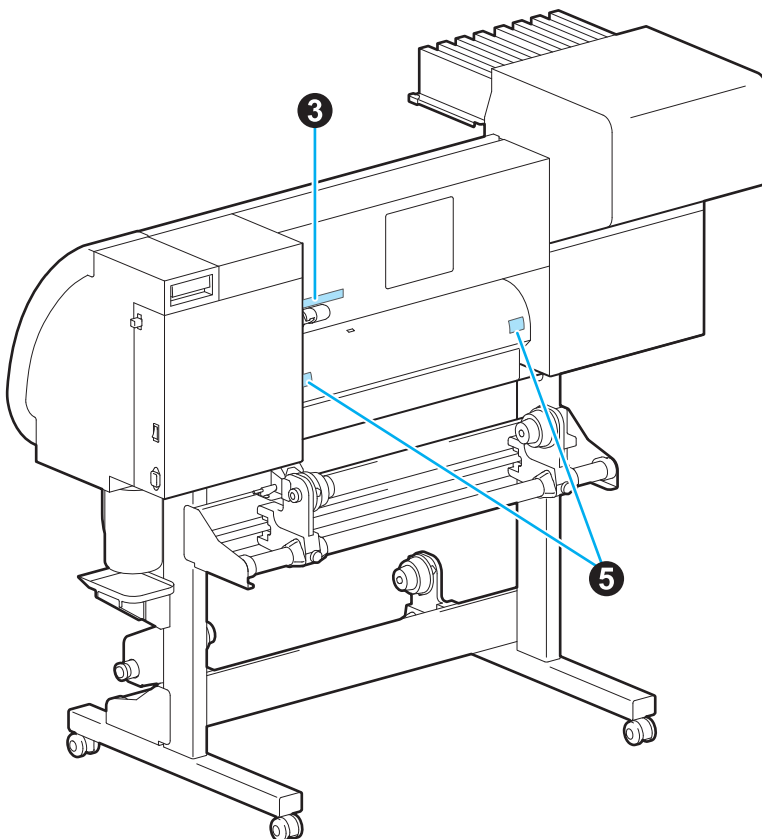
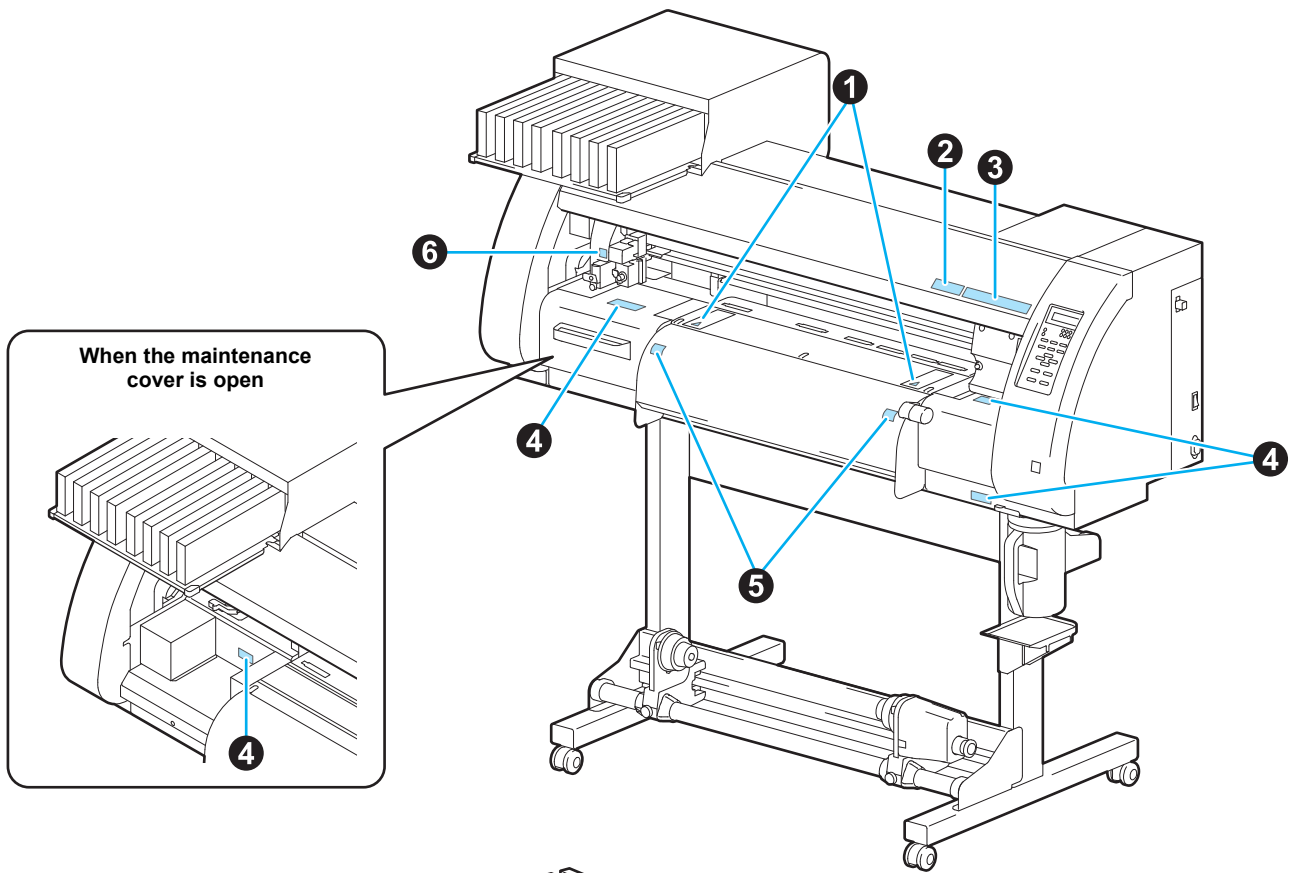

- Do not disassemble the ink cartridges or refill them with ink.
- Ink may freeze if left in a cold place for a long time.
- If ink has frozen, thaw it at room temperature (25°C) for more than three hours before use.

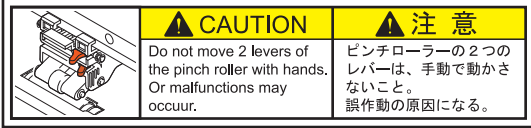
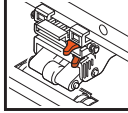
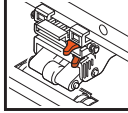
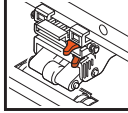

Warning Labels

Warning labels are attached to this machine. Be sure to fully understand the warnings given on the labels. If a warning label is illegible due to stains or has come off, purchase a new one from a distributor or our service office.



No.	Order No.	Label						
1	M904810							
2	M905935	 <table border="1"> <tr> <td></td> <td>CAUTION Do not move 2 levers of the pinch roller with hands. Or malfunctions may occur.</td> <td>注意 ピンチローラーの2つのレバーは、手で動かさないこと。誤作動の原因になる。</td> </tr> </table>		CAUTION Do not move 2 levers of the pinch roller with hands. Or malfunctions may occur.	注意 ピンチローラーの2つのレバーは、手で動かさないこと。誤作動の原因になる。			
	CAUTION Do not move 2 levers of the pinch roller with hands. Or malfunctions may occur.	注意 ピンチローラーの2つのレバーは、手で動かさないこと。誤作動の原因になる。						
3	M905811	 <table border="1"> <tr> <td></td> <td>警告 手指和身体请勿靠近运转部位，以免造成危险</td> <td>警告 危険な稼働部 指や体を近づけないように</td> <td>WARNING -HAZARDOUS MOVING PARTS- Keep fingers and other body parts away.</td> <td>WAARSCHUWING GEFÄHRLICHE BEWEGLICHE TEILE Finger und andere Körperteile fernhalten.</td> <td>AVERTISSEMENT PIECES MOBILES DANGEREUSES Doigts et autres parties du corps sont hors de portée.</td> </tr> </table>		警告 手指和身体请勿靠近运转部位，以免造成危险	警告 危険な稼働部 指や体を近づけないように	WARNING -HAZARDOUS MOVING PARTS- Keep fingers and other body parts away.	WAARSCHUWING GEFÄHRLICHE BEWEGLICHE TEILE Finger und andere Körperteile fernhalten.	AVERTISSEMENT PIECES MOBILES DANGEREUSES Doigts et autres parties du corps sont hors de portée.
	警告 手指和身体请勿靠近运转部位，以免造成危险	警告 危険な稼働部 指や体を近づけないように	WARNING -HAZARDOUS MOVING PARTS- Keep fingers and other body parts away.	WAARSCHUWING GEFÄHRLICHE BEWEGLICHE TEILE Finger und andere Körperteile fernhalten.	AVERTISSEMENT PIECES MOBILES DANGEREUSES Doigts et autres parties du corps sont hors de portée.			
4	M903330							
5	M903239							
6	M903405							

Inquiry Sheet

Use this sheet for troubles and abnormal functioning of the machine.
Fill in the following necessary items and fax the sheet to our service office.

Company name	
Person in charge	
Phone number	
Machine model	
Used OS	
Machine information^{*1}	
Error message	
Inquiry details	

*1. See "Confirming Machine Information" (☞ P.5-14) of "Chapter 5 Extended Functions - Common Settings -" and fill in the sheet.



Function Flowchart

Print mode

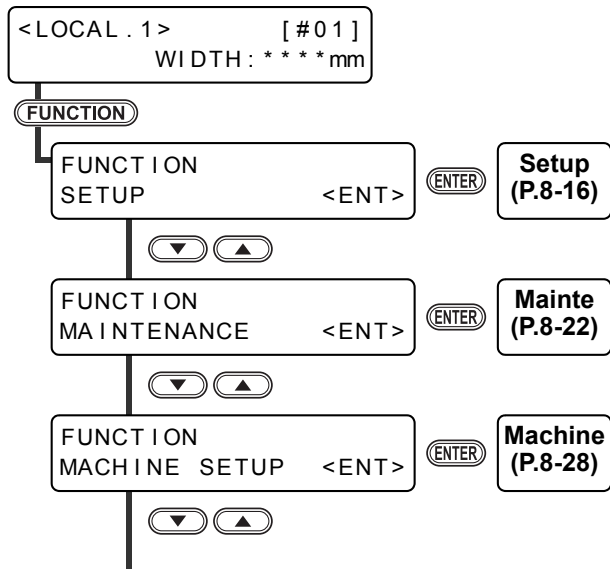

Cut mode

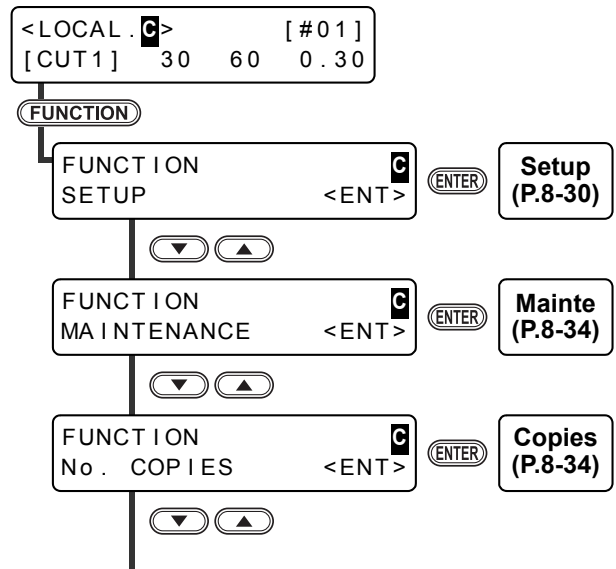

Common setup



Display

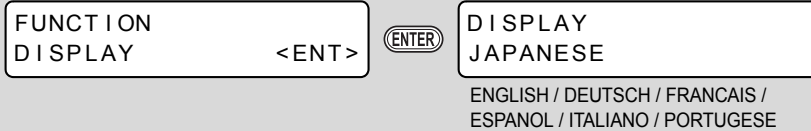

LOCAL Menu on the Printer Mode

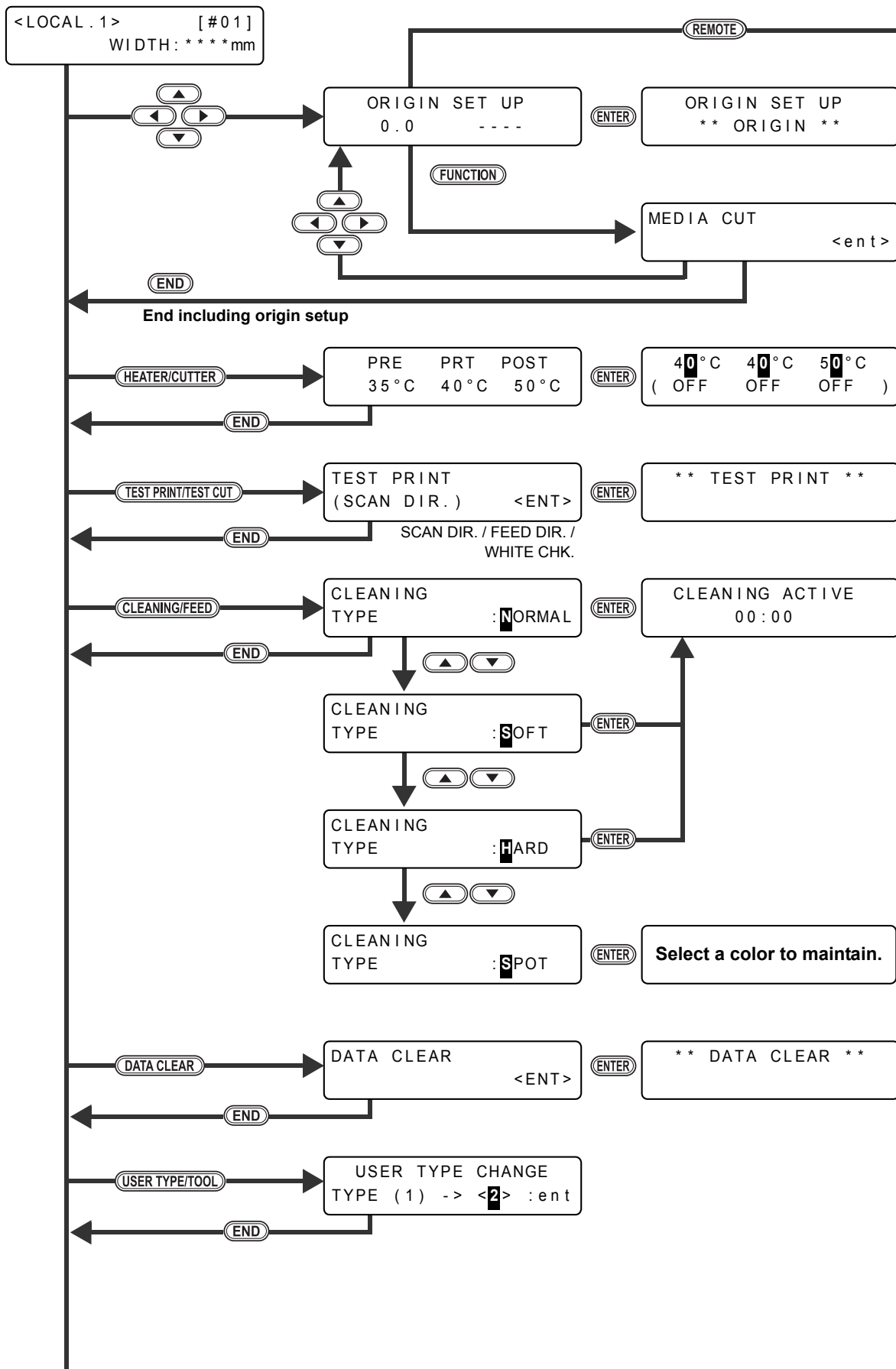

To P8-12

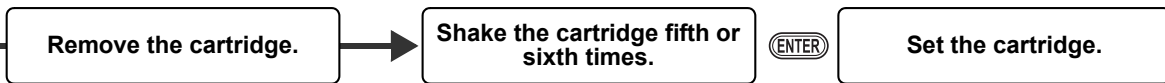
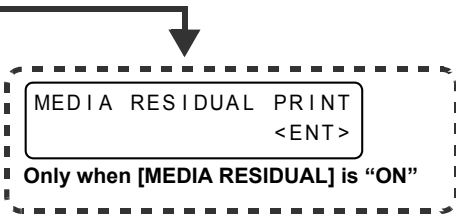

From P8-10

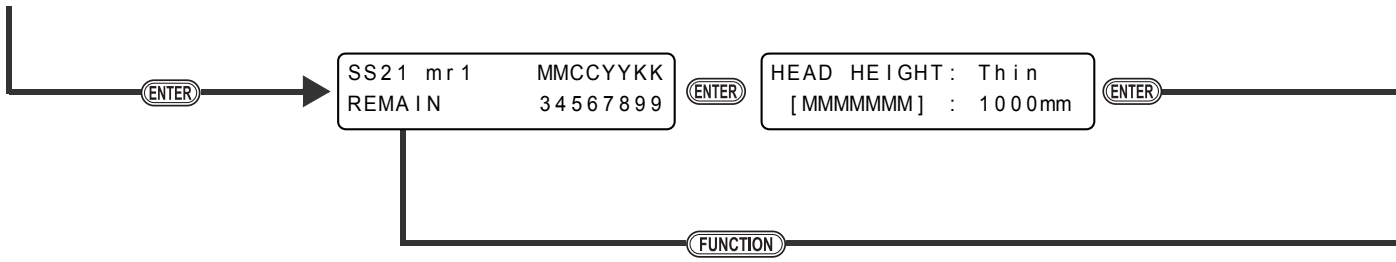

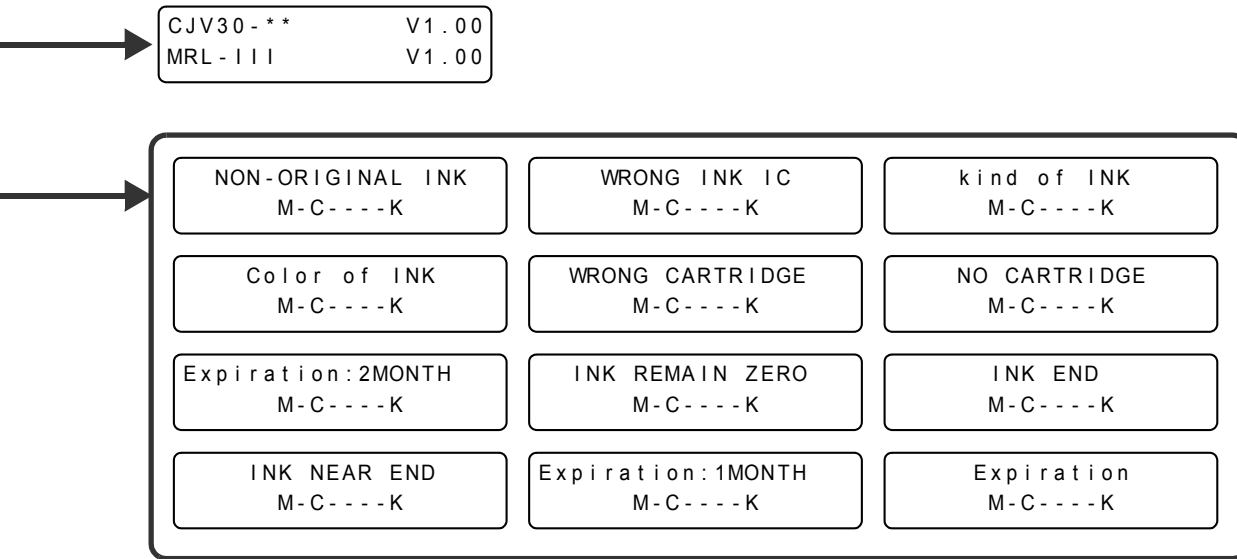

LOCAL Menu on the Cut Mode

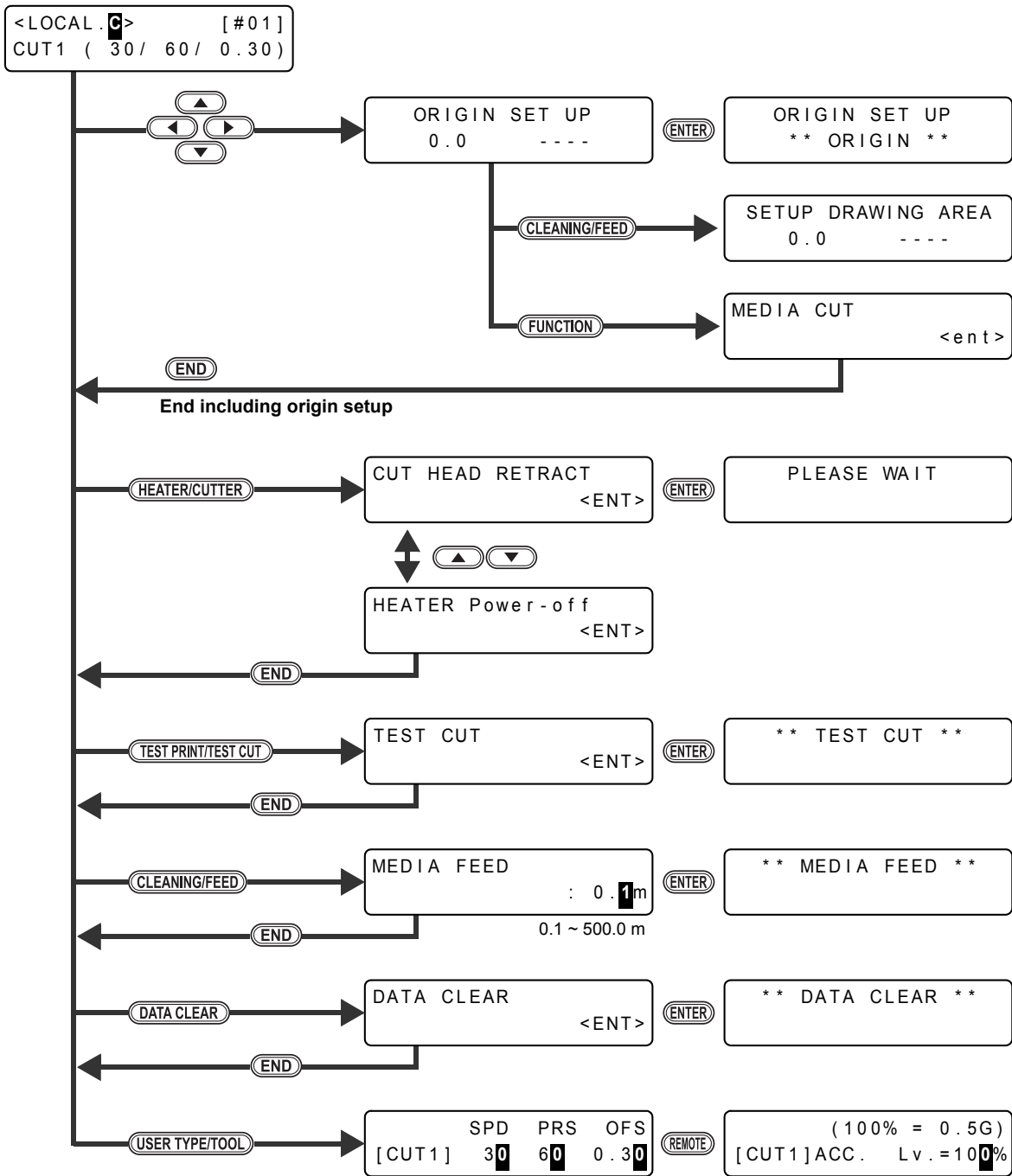



Setup (Printer Mode)

SETUP
SELECT :TYPE.1

TYPE.2
TYPE.3
TYPE.4

[1]
PINCH ROLLER <ent>

ENDS :HIGH [H____H]
INNER:OFF No.6to1

[1]
MEDIA COMP. <ent>

[1]MEDIA COMP.
PRINT START :ent

[1]
DROP.POScorrect<ent>

[1]DROP.POScorrect(L)
PRINT START :ent

[1]
HEATER <ent>

[1]HEATER
SET TEMP. <ent>

[1]HEATER
SET TIME <ent>

[1]
PRINT MODE <ent>

[1]PRINT MODE
DRAFT QUALITY <ent>

[1]PRINT MODE
FINE QUALITY <ent>

To P8-18

To P8-18



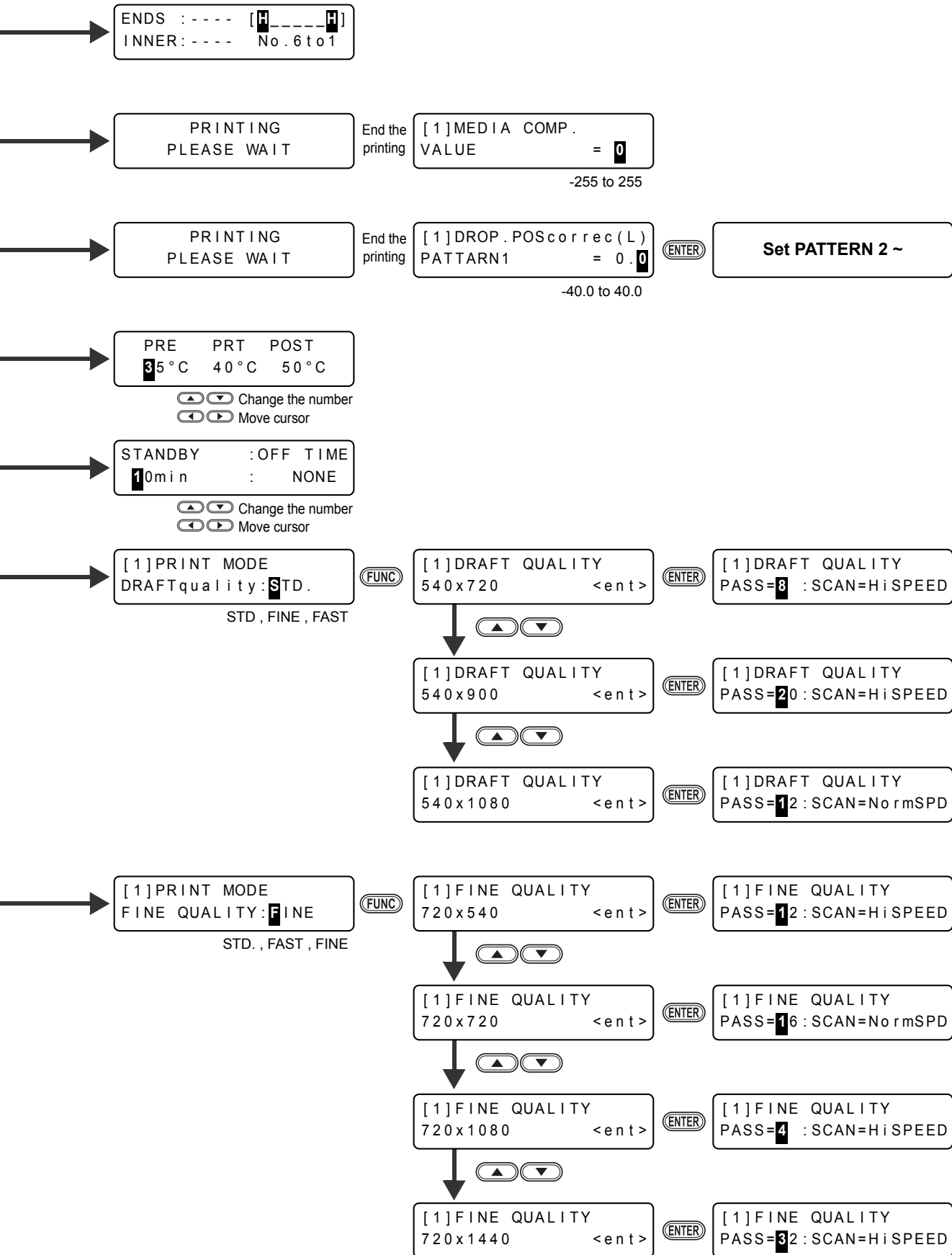

From P8-16

From P8-16

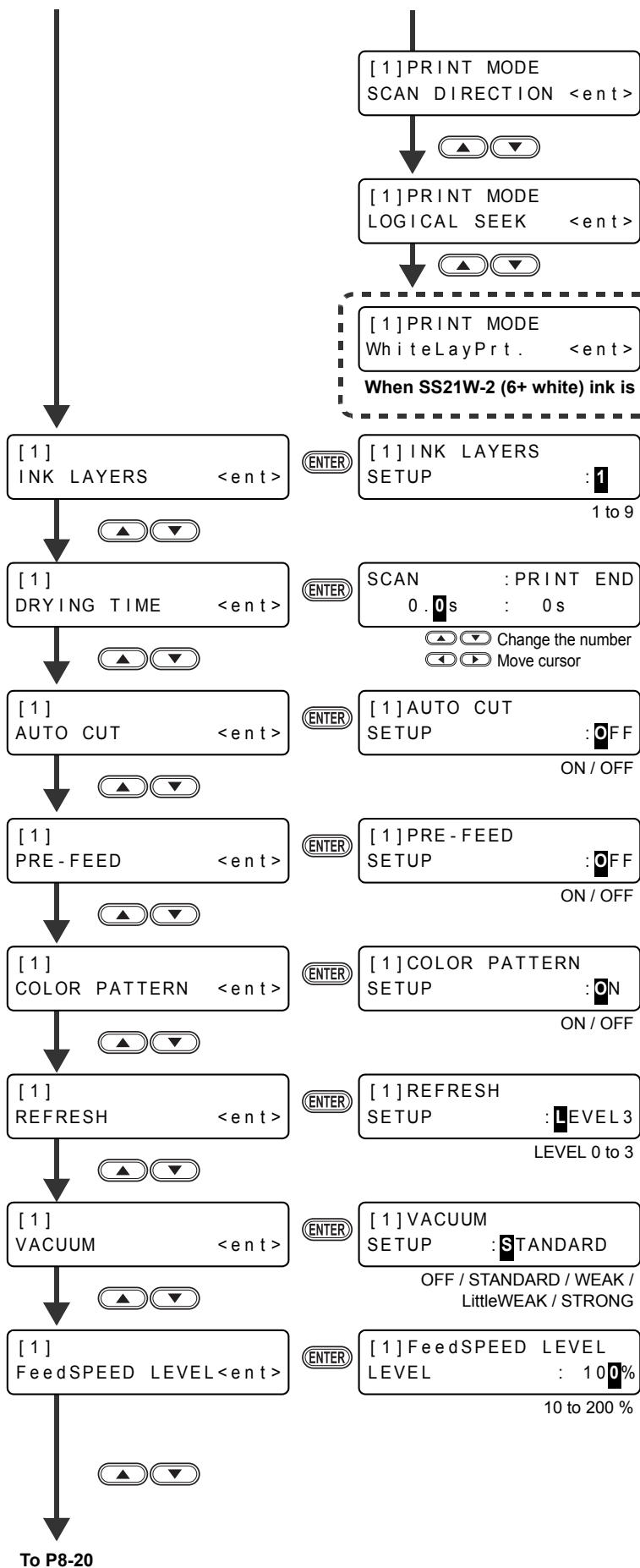

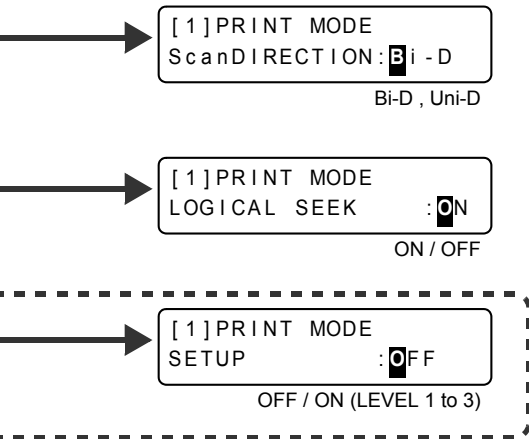

From P8-18

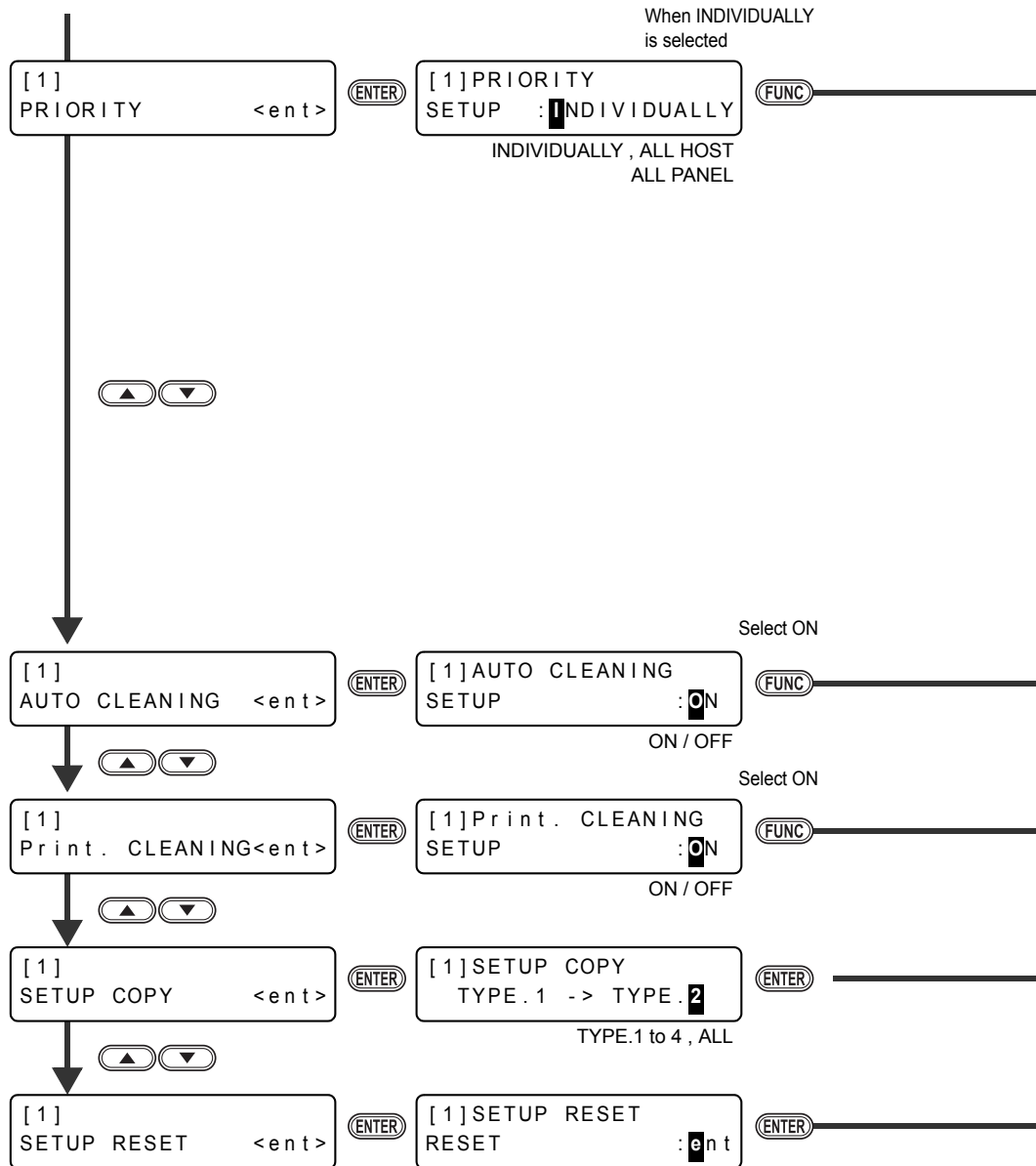

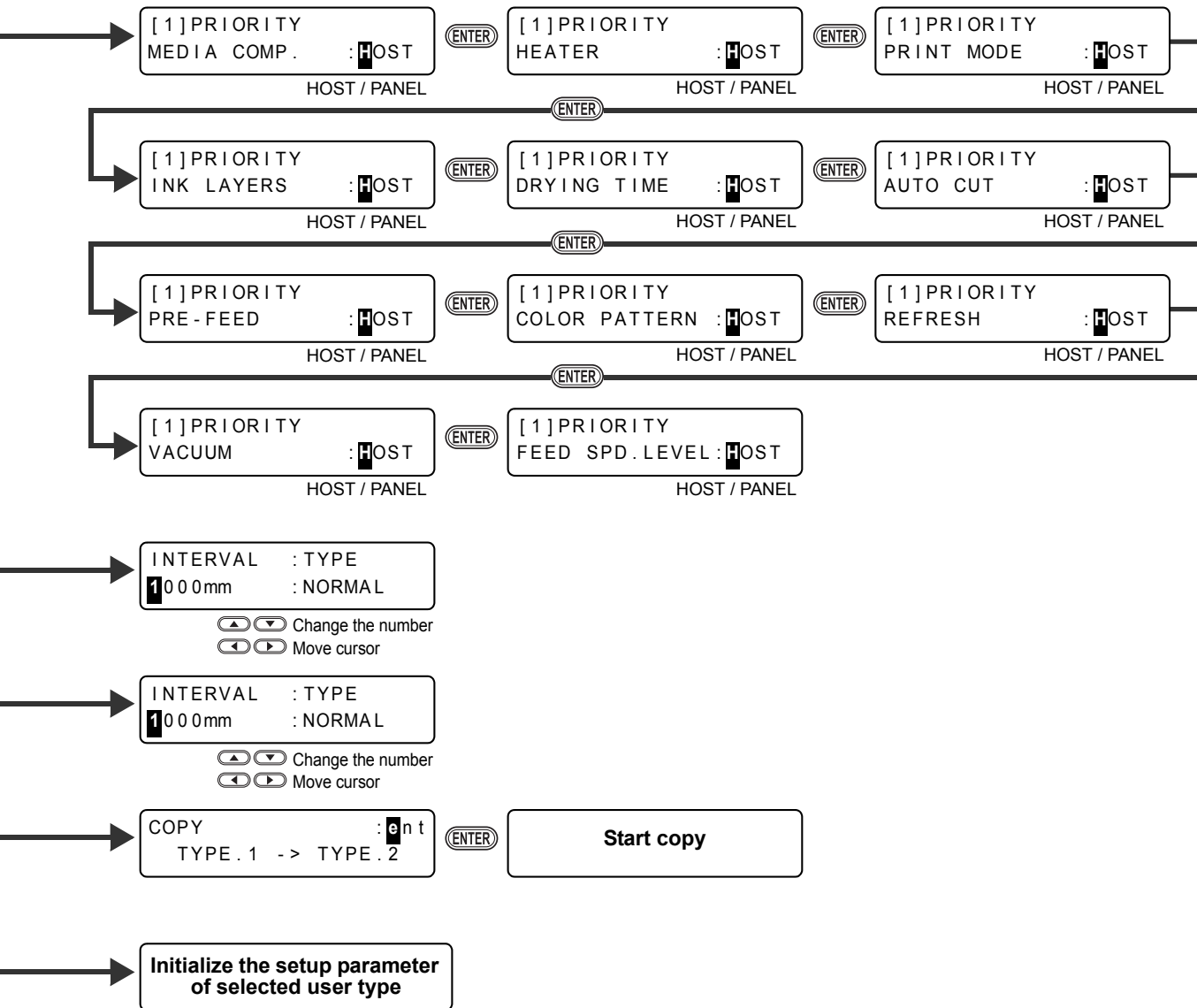

Mainte (Printer Mode)

MAINTENANCE
ST.MAINTENANCE <ent>

ENTER

ST.MAINTENANCE
CARIAGE OUT <ent>

ENTER

ST.MAINTENANCE
COMPLETED :ent

ENTER



ST.MAINTENANCE
WIPER REPLACE <ent>

ENTER

ST.MAINTENANCE
COMPLETED :ent

ENTER



ST.MAINTENANCE
NOZZLE WASH <ent>

ENTER

WIPER CLEANING
COMPLETED(NEXT) :ent

ENTER



ST.MAINTENANCE
PUMP TUBE WASH <ent>

ENTER

ST.MAINTENANCE
COMPLETED :ent

ENTER



ST.MAINTENANCE
COSTODY WASH <ent>

ENTER

WIPER CLEANING
COMPLETED(NEXT) :ent

ENTER

MAINTENANCE
CR.MAINTENANCE <ent>

ENTER

CR.MAINTENANCE
Remove the cover:ent

ENTER

**Remove
maintenance cover**

ENTER



To P8-24



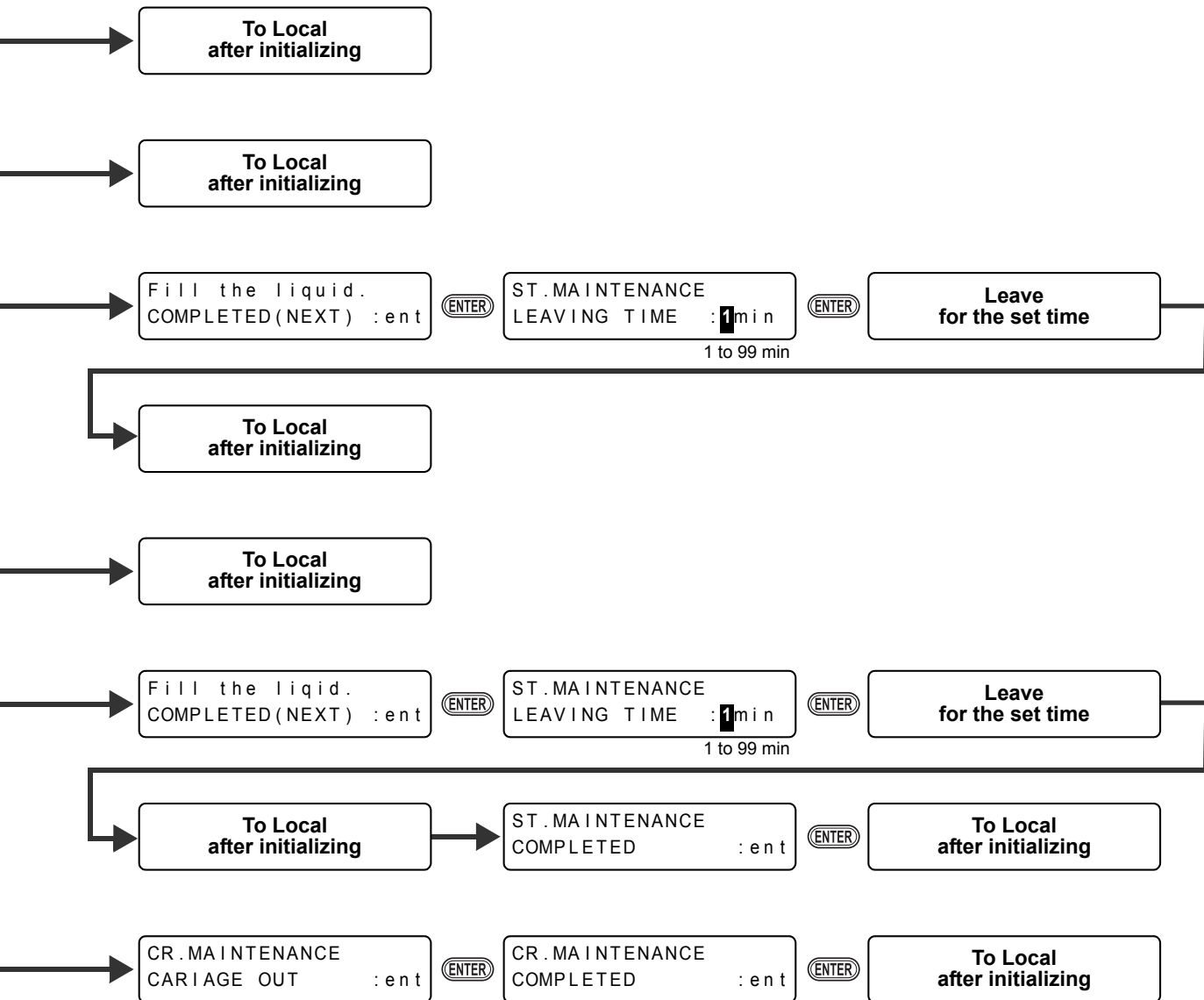

From P8-22

MAINTENANCE
HD.MAINTENANCE <ent>

ENTER

HD.MAINTENANCE
FILL UP INK <ent>

ENTER

FILLING UP
00:00



HD.MAINTENANCE
DISCHARGE&WASH <ent>

ENTER

Remove: InkCartridges
MMCCYYKK

ENTER



HD.MAINTENANCE
MaintWashLiquid<ent>

ENTER

MaintWashLiquid
FILLING UP <ent>

ENTER



MaintWashLiquid
DISCHARGE <ent>

ENTER

MAINTENANCE
SLEEP SETUP <ent>

ENTER

SLEEP SETUP
REFRESH <ent>

ENTER

SLEEP SETUP
REFRESHinterval = 4h

OFF/1 to 168h



SLEEP SETUP
PUMP TUBE WASH <ent>

ENTER

SLEEP SETUP
WASH INTERVAL = 4h

OFF/1 to 168h



SLEEP SETUP
CLEANING <ent>

ENTER

SLEEP SETUP
CLEAN.INTERVAL = 4h

OFF/1 to 168h

FUNC



To P8-26



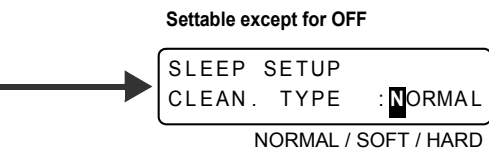
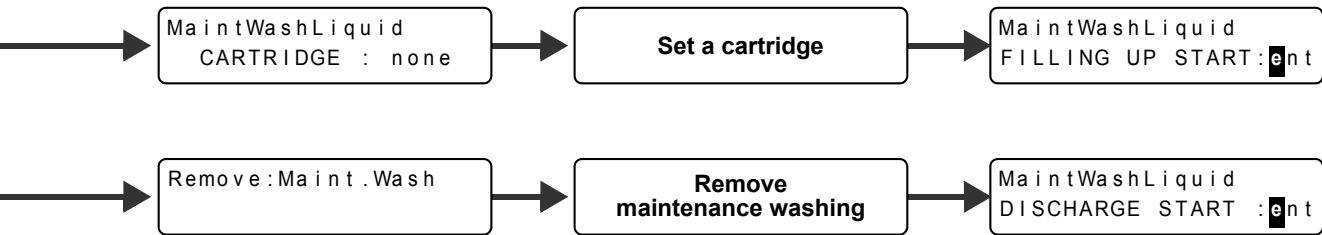
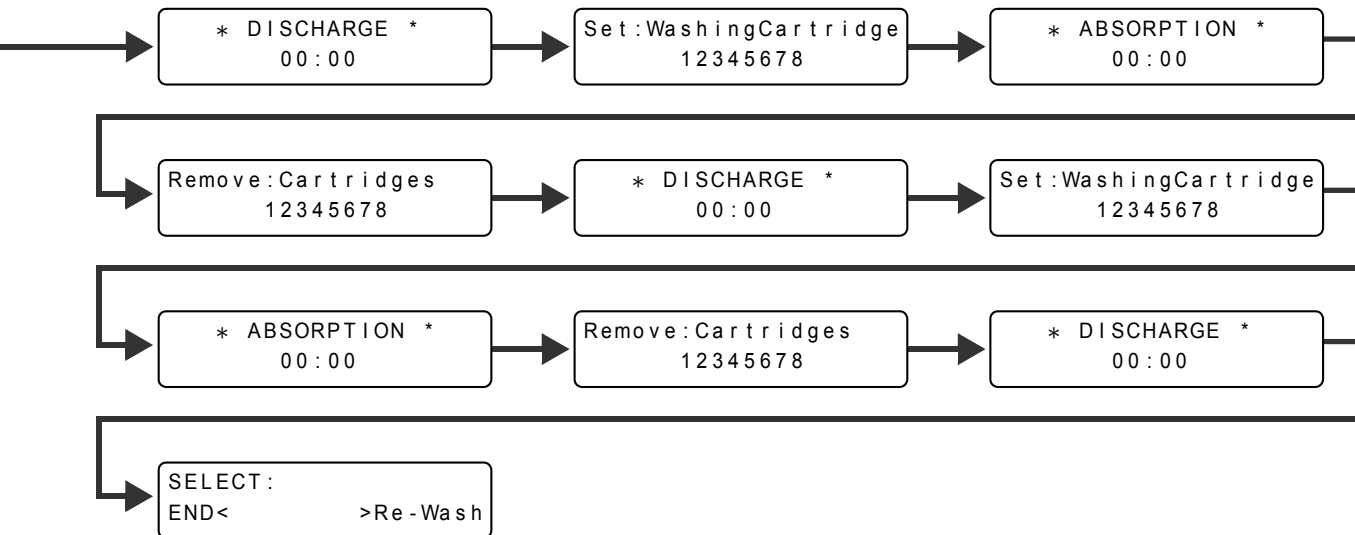

From P8-24

MAINTENANCE
ROUTINE SETUP <ent>

ENTER

ROUTINE SETUP
ROUTINE WIPING <ent>

ENTER

ROUTINE WIPING
SCAN COUNT <ent>

ENTER

▲ ▼

▲ ▼

▲ ▼

ROUTINE WIPING
TEMP.difference<ent>

ENTER

ROUTINE SETUP
REFRESH <ent>

ENTER

ROUTINE SETUP
REFRESHinterval = 4h
OFF/1 to 168h

▲ ▼

ROUTINE SETUP
PUMP TUBE WASH <ent>

ENTER

ROUTINE SETUP
WASH INTERVAL = 4h
OFF/1 to 168h

▲ ▼

ROUTINE SETUP
CLEANING <ent>

ENTER

ROUTINE SETUP
CLEAN . INTERVAL = 4h
OFF/1 to 168h

FUNC

MAINTENANCE
WIPER LEVEL <ent>

ENTER

WIPER LEVEL
LEVEL : 10 / 10
1/10 to 10/10

▲ ▼

MAINTENANCE
InkTankReplac e <ent>

ENTER

InkTankReplac e
REPLACE : ent

▲ ▼

MAINTENANCE
WHITE MAINT E . <ent>

ENTER

WHITE MAINT E .
SELECT : LEVEL 1

ENTER

SHAKE WHITE INK
CARTRIDGES : ent

ENTER

▲ ▼

WHITE MAINT E .
SELECT : LEVEL 2

ENTER

SHAKE WHITE INK
CARTRIDGES : ent

ENTER

▲ ▼

WHITE MAINT E .
SELECT : LEVEL 3

ENTER

SHAKE WHITE INK
CARTRIDGES : ent

ENTER

MAINTENANCE
MEDIA RESIDUAL <ent>

ENTER

MEDIA RESIDUAL
SETUP : OFF
ON / OFF



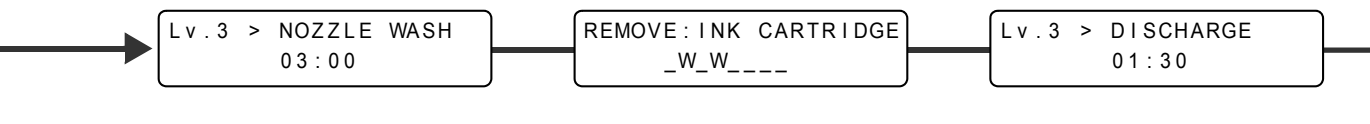
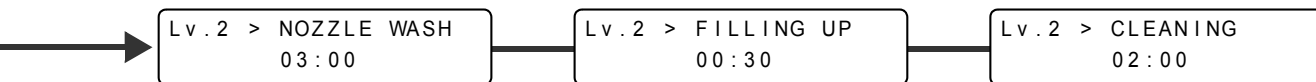
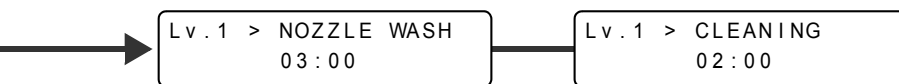
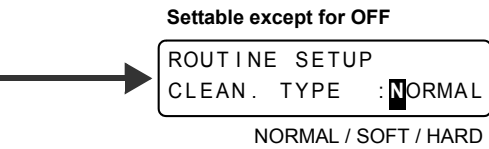
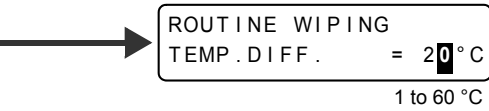
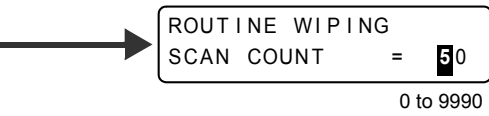

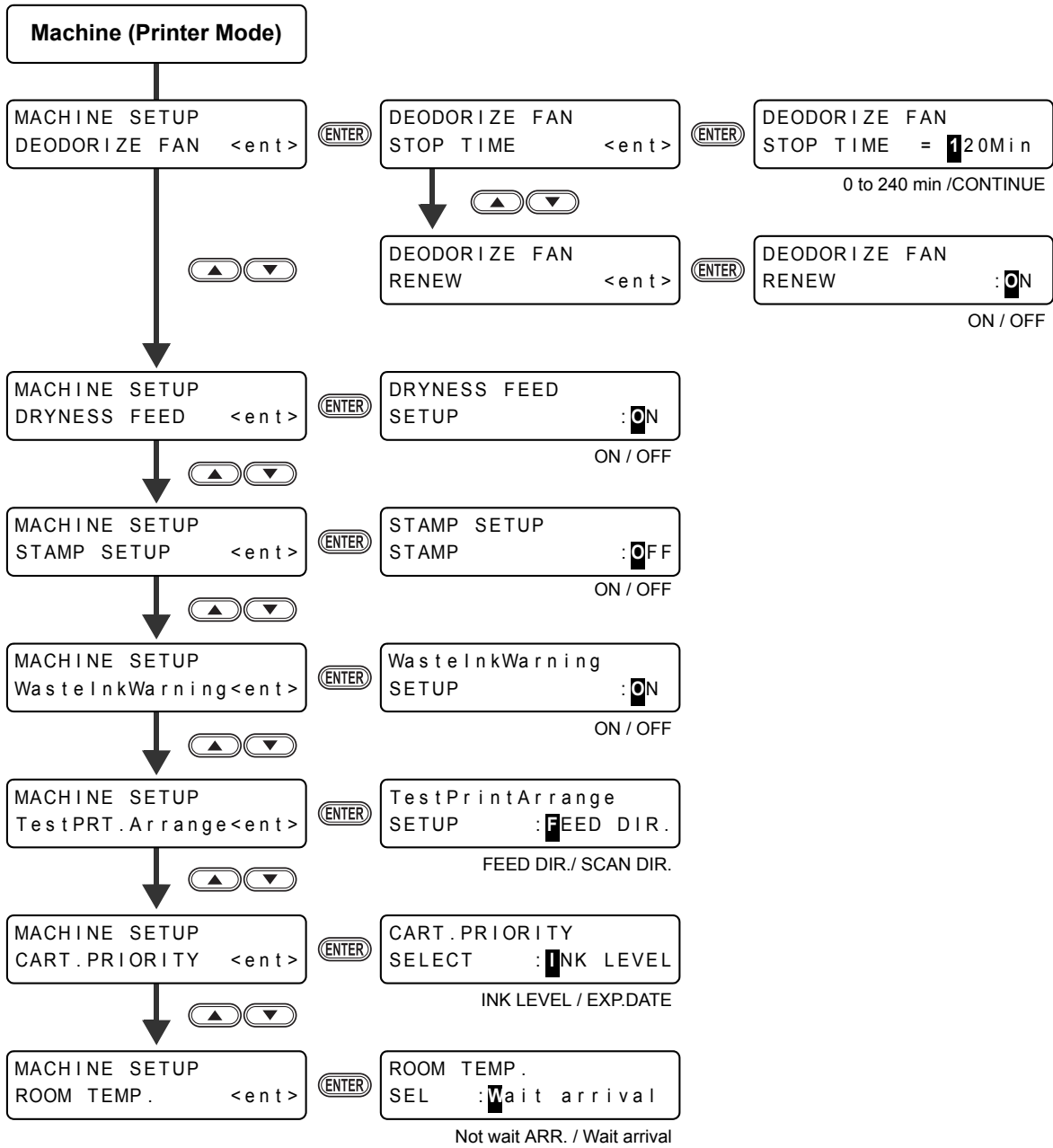



Setup (Cut Mode)

SETUP
SELECT : CUT1

CUT2
CUT3
PEN
HALF

[CUT1]
PINCH ROLLER <ent>

ENDS : HIGH [H____H]
INNER : OFF No. 6 to 1

[CUT1]
MARK DETECT <ent>

[CUT1] MARK DETECT
DETECT : OFF

OFF, 1pt, 2pt X,
2pt Y, 3pt, 4pt

[CUT1]
P/C ADJUST <ent>

[CUT1] P/C ADJUST
P/C ORIGIN OFS. <ent>

[CUT1] P/C ADJUST
P/C SCALE ADJ. <ent>

[CUT1]
CUT MODE <ent>

[CUT1] CUT MODE
SETUP : STD.

STD. / FINE / FAST

[CUT1]
AUTO CUT <ent>

[CUT1] AUTO CUT
SETUP : OFF

OFF / ON

To P8-32



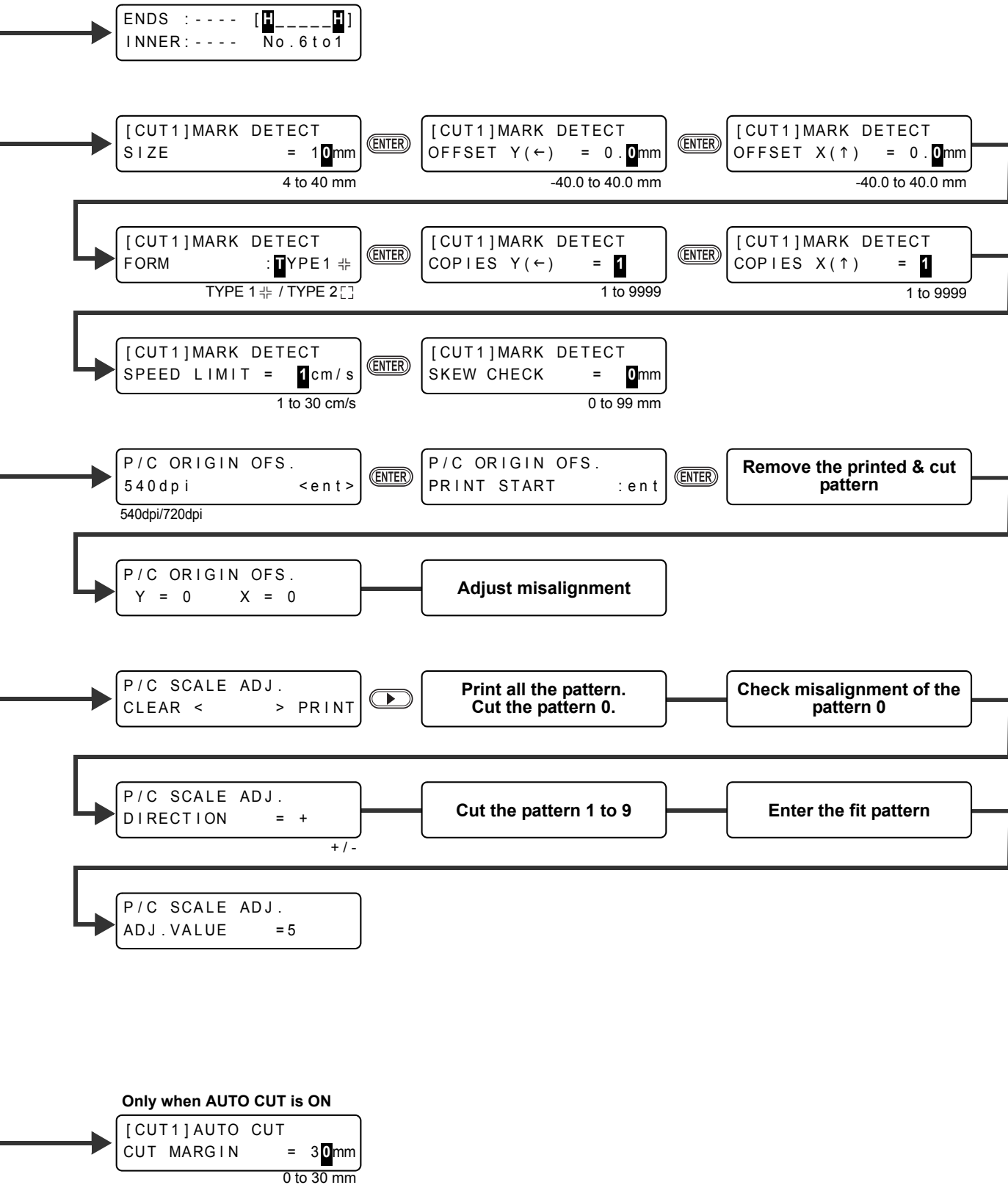

From P8-30

Only when tool condition [HALF] is selected

Not displayed when tool condition [PEN] is selected

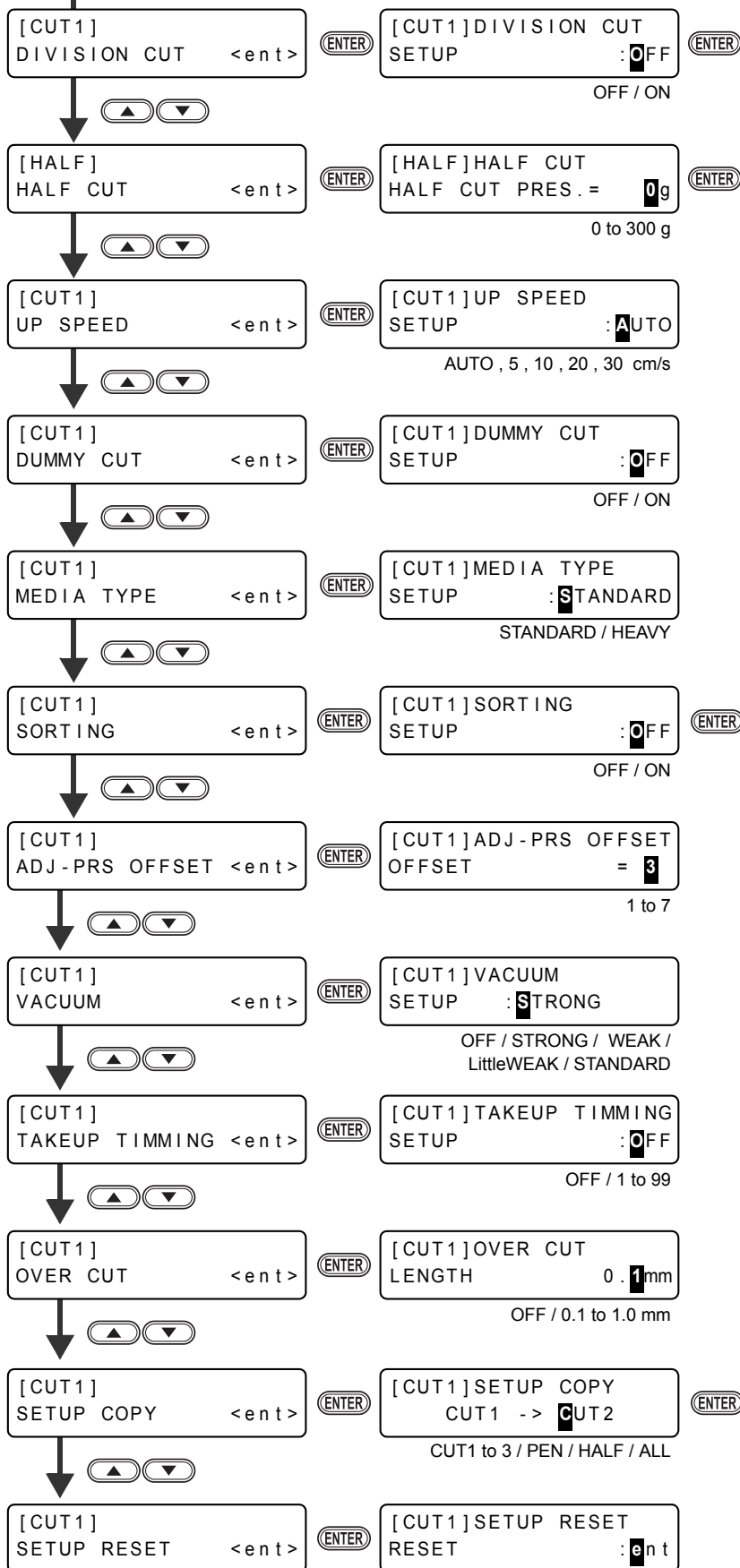

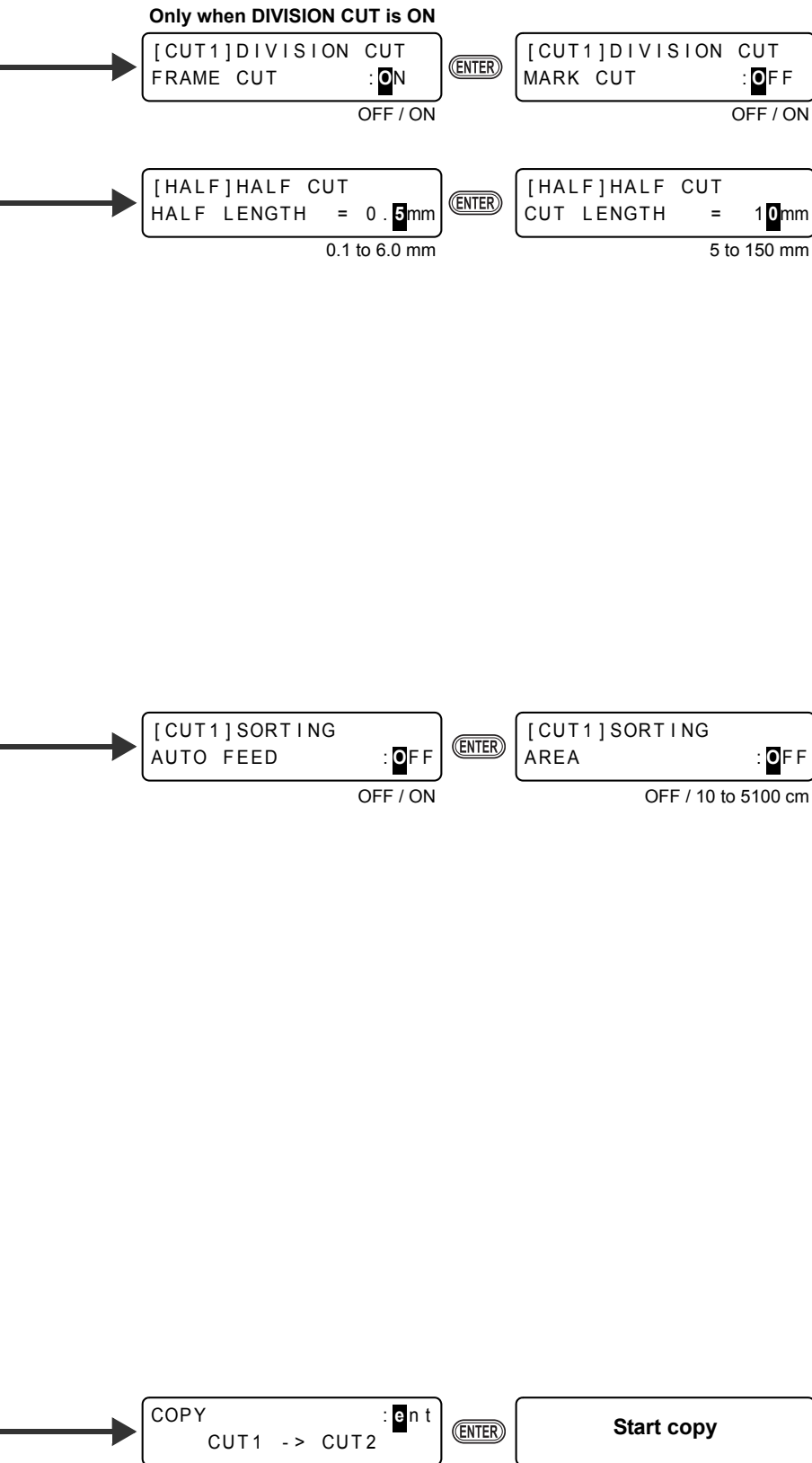

Mainte (Cut Mode)

MAINTENANCE
MARK SENSOR <ent>

ENTER

MARK SENSOR
SENSOR CHECK <ent>

ENTER

SENSOR CHECK
ORIGIN SET :ent

ENTER

▲ ▼

MARK SENSOR
POINTER OFFSET <ent>

ENTER

Draw pattern

MARK SENSOR
LEVEL ADJUST <ent>

ENTER

LEVEL ADJUST
OUT: 0000 IN: 0000

Only when LOGO is selected

MAINTENANCE
SAMPLE CUT <ent>

ENTER

SAMPLE CUT
SELECT :LOGO

ENTER

SAMPLE CUT
LOGO :100%

ENTER

LOGO / CUT

1 to 999 %

▲ ▼

MAINTENANCE
MEDIA CUT <ent>

ENTER

MEDIA CUT
INTERVAL = 500mm

ENTER

MEDIA CUT
FRONT CUT OFF = 30mm

ENTER

10 to 10000 mm

0 to 500 mm

▲ ▼

MAINTENANCE
STEP SIZE <ent>

ENTER

STEP SIZE
SIZE = 0.025

ENTER

0.025 / 0.01

▲ ▼

MAINTENANCE
TOOL REPLACE <ent>

ENTER

TOOL REPLACE
ACTION :ent

ENTER

TOOL REPLACE
COMPLETED :ent

ENTER

Copies (Cut Mode)

No. COPIES
COPIES = 1

ENTER

1 to 999

No. COPIES
INTERVAL = 2mm

ENTER

0 to 30 mm

**Operation starts after
changing to REMOTE**



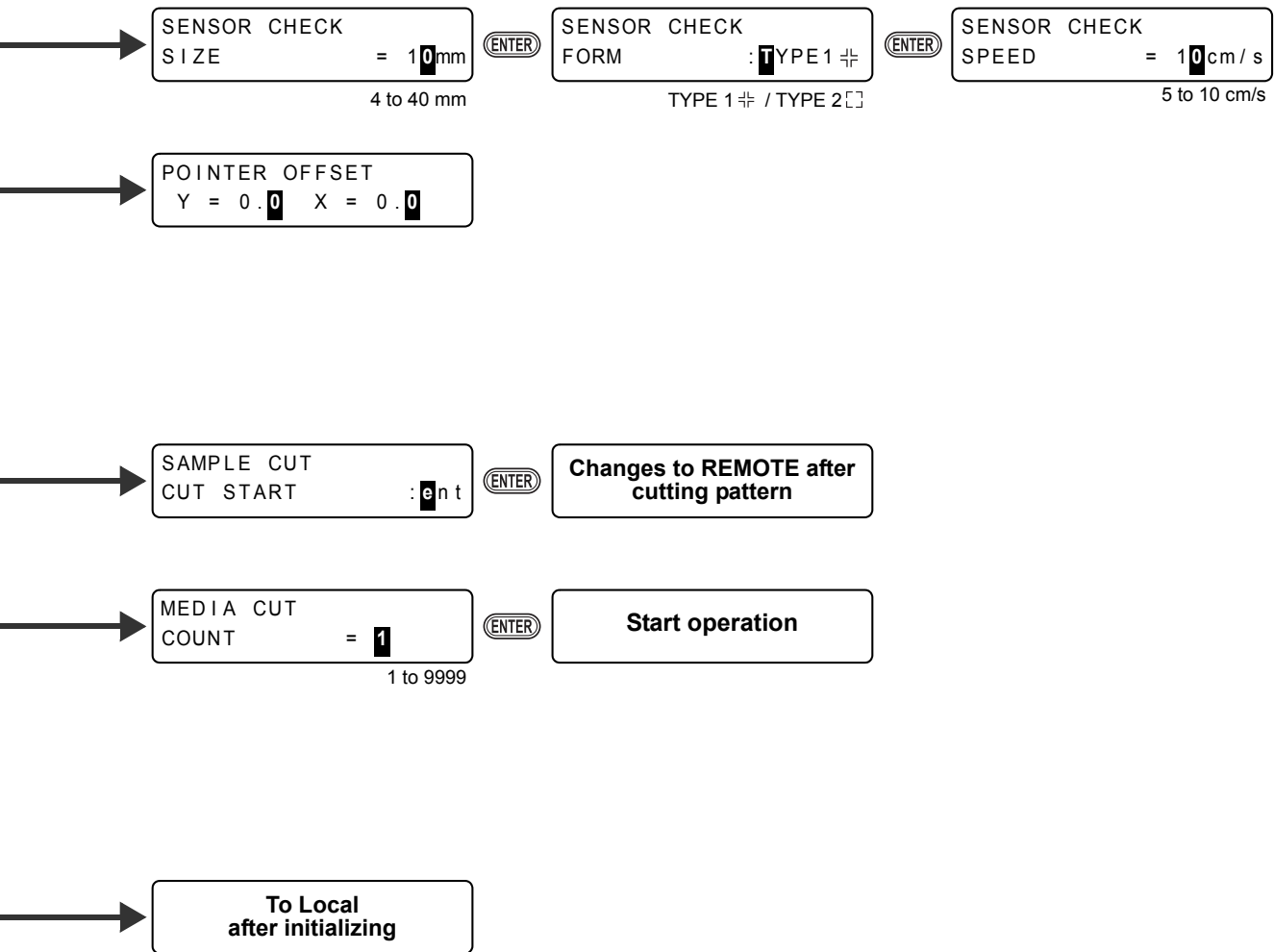

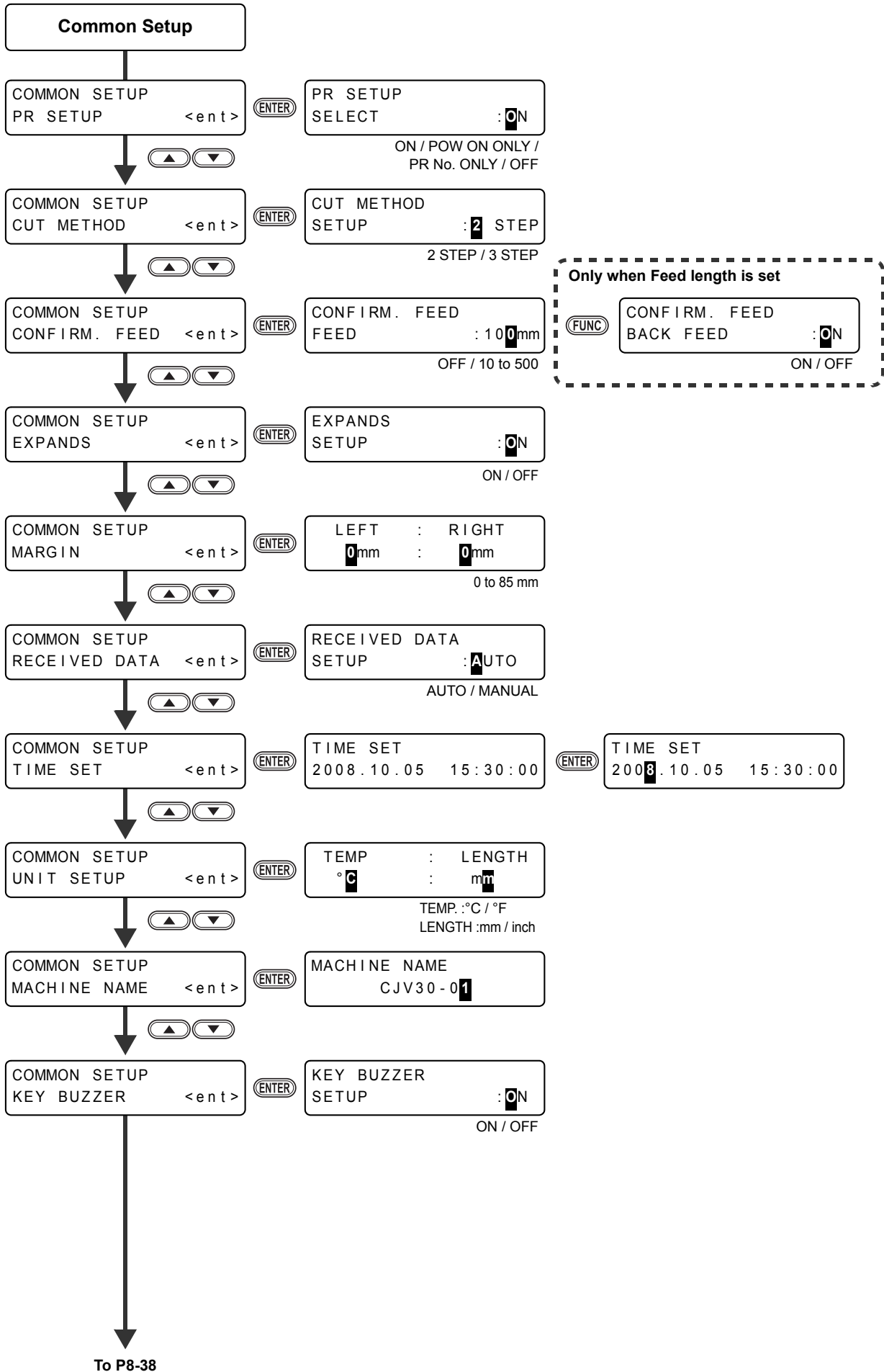



From P8-36

