

Operation Guide for Print&Cut

Thank you for purchasing our printer cutter CJV30 series.

Combining Printer cutter CJV30 series with cutting software [FineCut] or [SimpleStudio] or Software RIP [RasterLinkPro4 SG], you can create a seal or a sticker easily.

First, confirm the following items:

Before creating a seal or a sticker, the preparation for CJV30 series and the application to be used is required. First, prepare the followings:

About system configuration (P. 2)

The explanation of the system configuration to Print&Cut is described.

Prepare CJV30 series (P. 3)

The explanation of the preparation for CJV30 series such as the way of turning on the power supply, setting method of a medium, etc. is provided.

Prepare the application (P. 7)

The explanation of the application to be used is provided.
For the installation of the application software, refer to each Operation Manual.

Let's create a seal/a sticker.

If CJV30 series and the application to be used are prepared, create a seal by using sample images included in the attached CD.

When using Illustrator (FineCut) (P. 11)

The procedure to create a seal or a sticker using [FineCut], the plug-in software of Illustrator is provided.

When using CorelDRAW (FineCut) (P. 13)

The procedure to create a seal or a sticker using [FineCut], the plug-in software of CorelDRAW is provided.

When using SimpleStudio (P. 15)

The procedure to create a seal or a sticker using SimpleStudio is provided.

Print&Cut in RasterLinkPro4 SG (P. 19)

First, confirm the following items:

About system configuration

Print data and cut data created in Illustrator (FineCut) and CorelDRAW (FineCut) or SimpleStudio will be sent to RasterLinkPro4 SG and output from it.

● The example of the system configuration when one PC is used



Data created in Illustrator (FineCut) and CorelDRAW (FineCut) or SimpleStudio will be output from RasterLinkPro4 SG.

● The example of the system configuration when multiple PCs are connected in the network

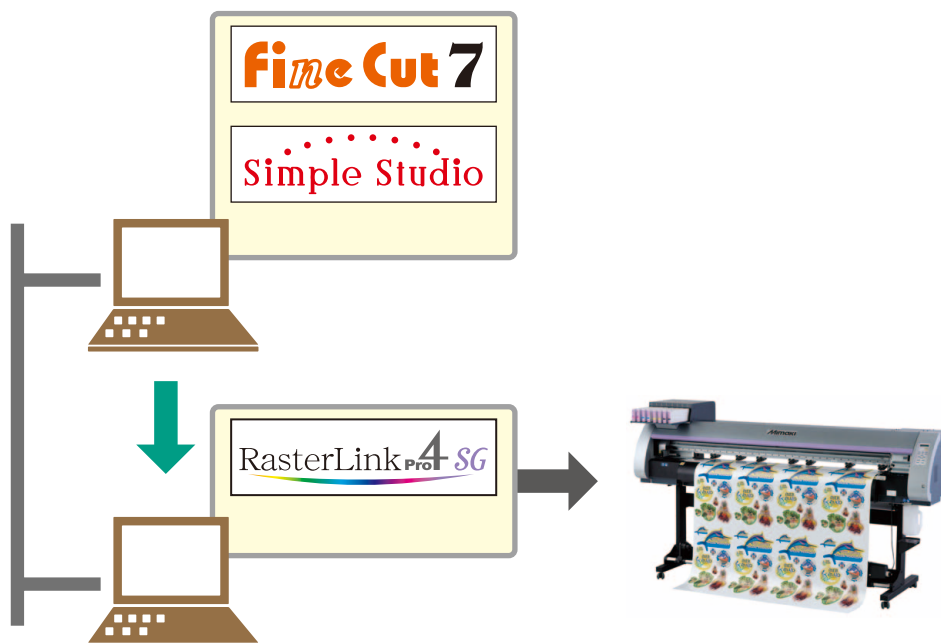

Data created in Illustrator (FineCut) and CorelDRAW (FineCut) or SimpleStudio will be sent to a PC in which RasterLinkPro4 SG in the network is installed and output will be performed from RasterLinkPro4 SG.

Prepare CJV30 series

Following the procedures below, prepare CJV30 series.

● Connect a PC in which RasterLinkPro4 is installed with CJV30 series.

1. Connect a PC in which RasterLinkPro4 SG is installed with CJV30.

- For details, refer to [P.1-12 to 13 of CJV30 Operation Manual](#).

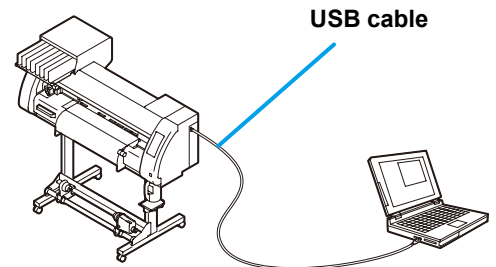

2. Turn on the power supply of CJV30.

- For details, refer to [P.2-8 to 9 of CJV30 Operation Manual](#).

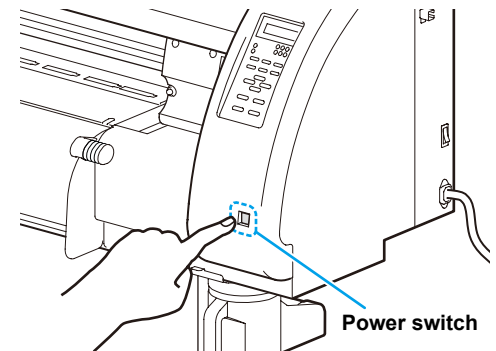

3. Attach the cutter blade.

- For details, refer to [P.2-10 to 12 of CJV30 Operation Manual](#).

- (1) Attach the cutter blade to the cutter holder.
- (2) Adjust the length of the blade edge drawn out depending on the kind of the cutter blade to be used or the medium type.

$$\text{Depth of the blade edge that cuts in} = \frac{(\text{Film thickness} + \text{Backing paper thickness})}{2}$$

- However, when film thickness is less than backing paper thickness:

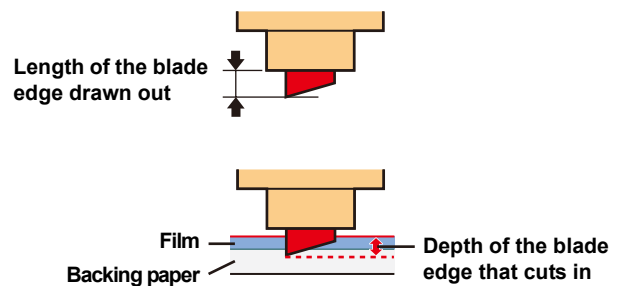

- (3) Attach the cutter holder to the tool holder.
- (4) Perform setting of cutting condition and test cutting to check if it cut well.

4. Before setting a medium, check the following items:

- (1) Checking the height of print head :
For details, refer to [P.2-15 of CJV30 Operation Manual](#).

Adjust the Height-adjusting lever depending on the medium to be used.

For details, refer to [P.2-16 “ For the Adjusting Leve and the Range ” of CJV30 Operation Manual](#).

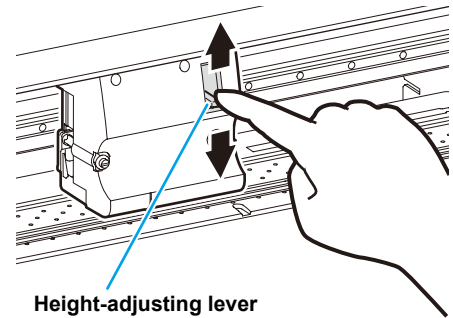

Height-adjusting lever

- (2) Adjusting position of Pinch roller :For details, refer to [P.2-17 of CJV30 Operation Manual](#).
Move the Pinch roller unit to adjust the position of Pinch roller.
Use the Pinch roller guide marks as guide.

To adjust the pinch roller from the front side:

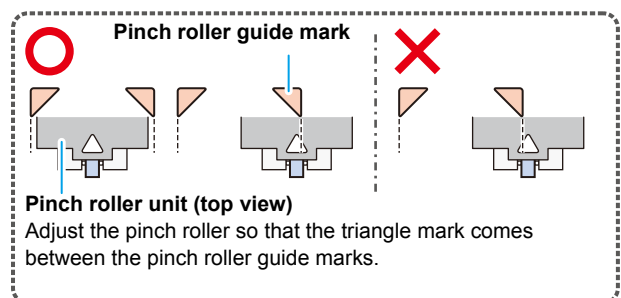

To adjust the pinch roller from the rear side:

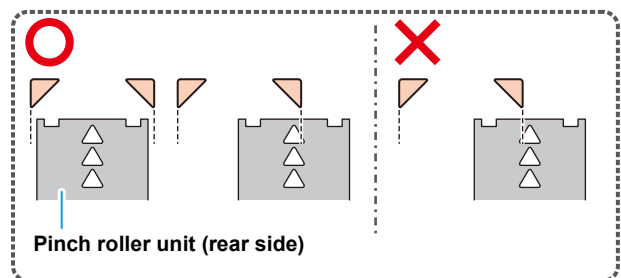

- (3) Checking the position of Roll stopper : For details, refer to [P.2-22 of CJV30 Operation Manual](#).

When seeing from the rear side

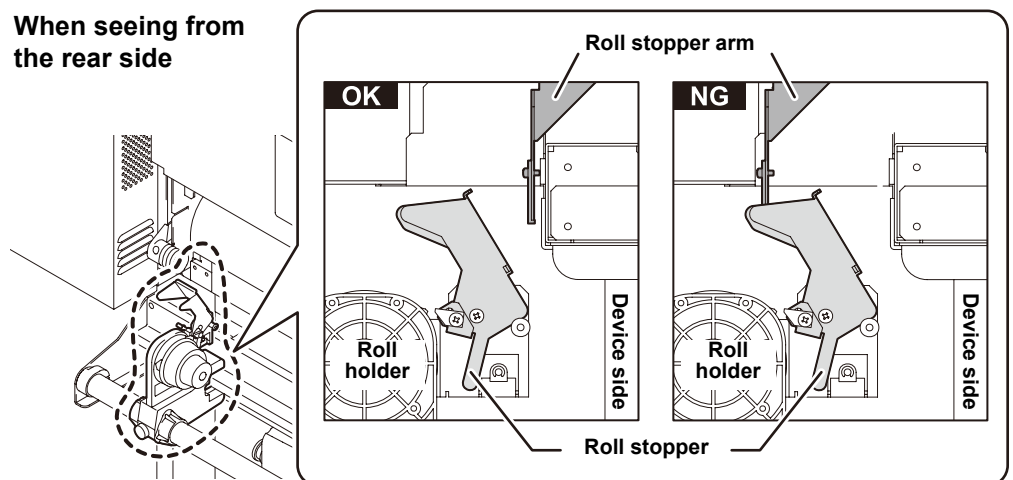

- The roll stopper works with the clamp lever. Do not push the clamp lever down while the roll stopper is caught between the roll stopper arm and the this machine. The roll stopper arm might be broken and the roll stopper function might be disabled.

- (4) Notes related to the setting position of the medium :
 For details, refer to [P.2-24 of CJV30 Operation Manual](#).
 Do not set the medium at the position beyond the Slit line on the platen.



- If the medium is set with its end exceeding the slit line on the platen, the medium may be lifted when it is fed obliquely. This may cause damage to the head.

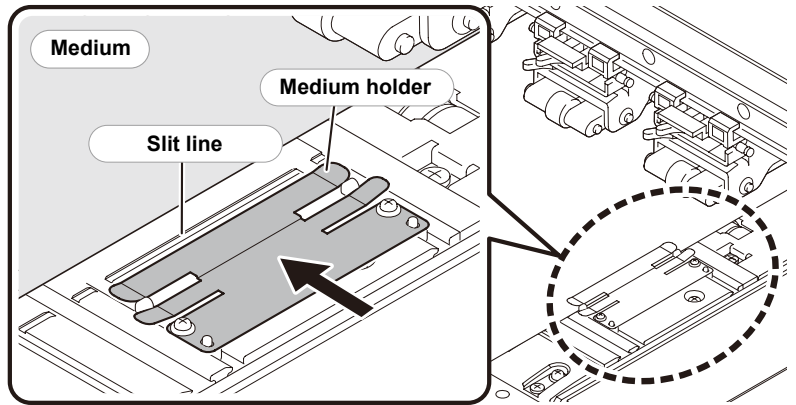

5. Set the medium.

- When setting the roll medium : [P.2-25 to 28 of CJV30 Operation Manual](#)
- When setting the leaf medium : [P.2-31 to 32 of CJV30 Operation Manual](#)
- Moving the clamp lever downward moves the screen to the pinch roller setting screen. For the setting of the pinch roller, refer to the following table.



The recommended value for the setting of the pinch roller pressure

• The figure above shows CJV30-160.

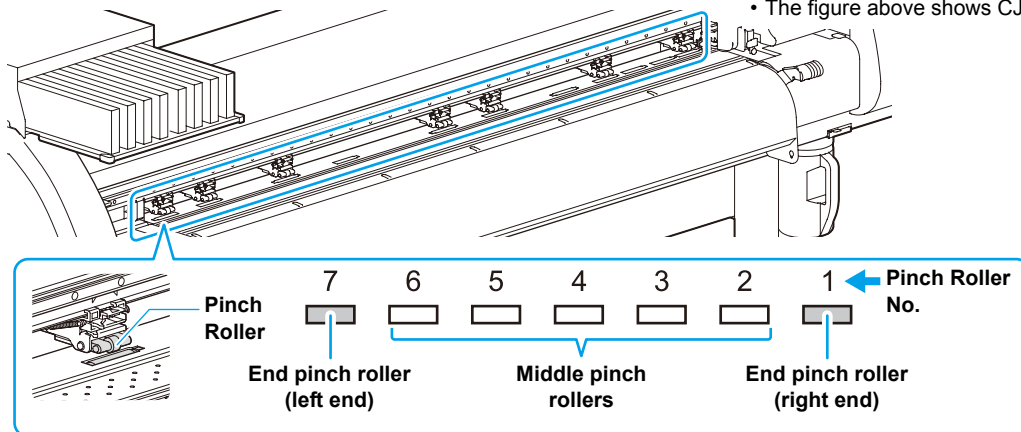

Mode to be used	Set pressure	Usage
When printing	ENDS:Middle INNER:Middle	For standard operation
	ENDS:High INNER:Low	Use this combination of settings when you want to minimize the traces of pinch rollers on the medium. • This setting may cause misalignment of the medium depending on the medium type, feeding rate, or medium width.
When cutting	ENDS:High INNER:High	For standard operation
	ENDS:High INNER:Low	Use this combination of settings when you want the streaks made by the pinch rollers on the medium to be unnoticeable. • This setting may cause misalignment of the medium depending on the medium type, feeding rate, or medium width.

Medium width	Pinch roller used when cutting
Less than 600mm	Both ends only
600 to 1300mm	Both ends + 1 middle pinch roller
1300mm or more	Both ends + 2 middle pinch rollers

6. Perform a test printing.

- Check if discharging defect such as nozzle clogging exists or not.
- For details, refer to [P.2-35 to 36 of CJV30 Operation Manual](#).

7. Perform a test cutting.

- Check if the length of the blade edge drawn out and the cutting pressure are proper.
 - For details, refer to [P.2-37 of CJV30 Operation Manual](#).
-



Pay attention to the following items when Print&Cut is performed:

- 1. When creating data with register marks, as there are some restrictions, perform it with much care.**
For details, refer to P.4-6 to 10 of CJV30 Operation Manual.
- 2. When using the taking-up device, weaken the torque.**
If the torque is too strong, the medium may not return to the register mark position when it drawn back to the cutting start position after printing in Print&Cut.
For details, refer to P.2-29 to 30 of CJV30 Operation Manual.
- 3. When using the taking-up device, so that the part on which print or cut has been completed would not touch the floor, the length of the feeding direction of the medium to be printed and cut repeatedly shall be within about 300mm.**
- 4. When cutting (automatic cutting) the medium automatically after Print&Cut, be careful that the printed surface does not adhere to each other.**
It is recommended that you have time to dry after printing.
Time to dry differs depending on the medium to be used, circumstances or print density.
- 5. When using RasterLinkPro4 SG, set "1 pt" to setting of "MARK DETECT" of CJV30.**
For details, refer to P.4-11 to 12 of CJV30 Operation Manual.
- 6. If "Setting timing of taking up" is not set to OFF, the automatic cutting is not performed.**
For details, refer to P.4-32 to 33 of CJV30 Operation Manual.
- 7. For the setting of the heater, set the value suited to each medium when printing. It is recommended that the heater is OFF when cutting.**
Perform setting of the heater when cutting in RasterLinkPro4 SG.
(Refer to Step 1-(3) on P. 19 Print&Cut in RasterLinkPro4 SG)
- 8. The heater that became OFF when cutting will return to the heater setting of printing at the following timing:**
 - When receiving print data
 - When pressing the [HEATER] key after making the status the print mode using the [MODE CHANGE] key of CJV30
 - When setting the heater temperature from RasterLinkPro4 SG

Prepare the application

Check if the required application for Print&Cut is ready.

● Prepare RasterLinkPro4 SG.

1. Check if RasterLinkPro4 SG is installed.

- If it is installed, the icon on the right is displayed on the PC desktop.
- For the installation, refer to [RasterLinkPro4 SG Installation Guide](#).



2. Check the connection with CJV30.

- (1) Is the power supply of CJV30 turned ON?
- (2) Is the PC in which RasterLinkPro4 SG is installed connected with CJV30?

3. Register the printer in RasterLinkPro4 SG.

- For Print&Cut in CJV30, the registration of the printer into RasterLinkPro4 SG is required.
- If the printer has already been registered, this operation can be skipped.

- (1) Select [All Programs] from [START] menu.
- (2) Click [Mimaki RasterLinkPro4 SG] and select [Printer Management].

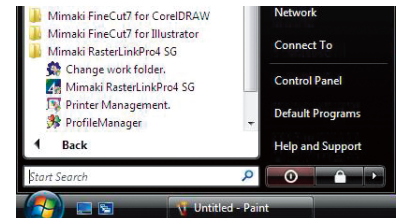

- (3) When the printer management dialog is displayed, click [Add].

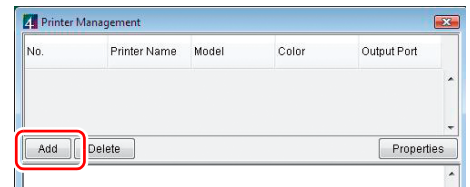

- (4) Set the printer information.
 - Model : CJV30
 - Color : Select depending on the device.
 - Output Port : USB2.0
 - Available Printers : Available printers: Select CJV30-01.
 - Printer Name : Enter the printer name. (The Hot folder of the name entered here is automatically created.)

- (5) Click [OK].
 - The confirmation screen is displayed. Clicking [OK] starts the registration of the printer.

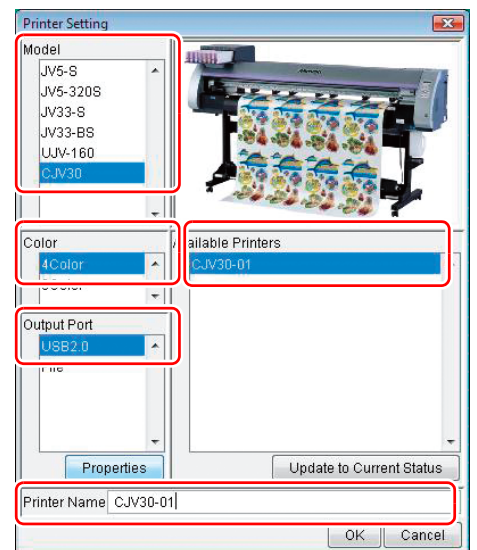

● Prepare FineCut (illustrator version)

1. Start Illustrator.

2. Check if the FineCut menu is displayed.

- If FineCut is installed properly, FineCut menu is displayed.
- For installation, refer to [P.6 of FineCut Operation Manual](#).

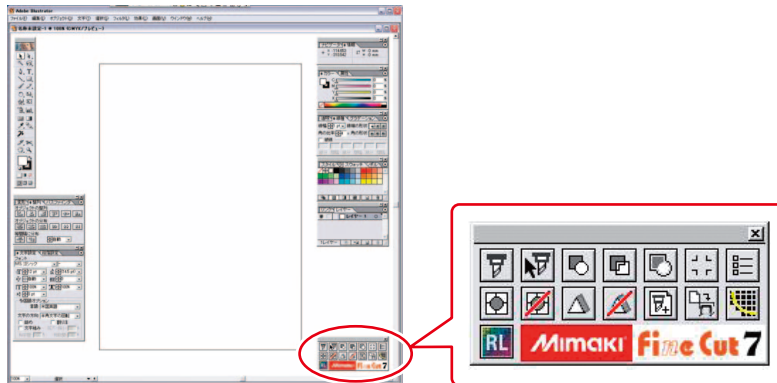

- “FineCut menu” is displayed automatically. If “FineCut menu” is not displayed, select [Show FineCut Menu] (select [Mimaki FineCut] for Illustrator 10 or later) from the [Window] menu in the Illustrator.

3. Click the [Plotter/User Setup] button in FineCut menu.

- The Plotter/User Setup screen is displayed.

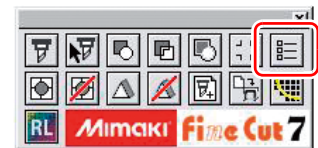

4. Select [CJV30] as the plotter type.

- For details, refer to [P.108 of FineCut Operation Manual](#).
- When creating a seal/a sticker continuously, proceed to [P. 11 “When using Illustrator \(FineCut\)”](#).

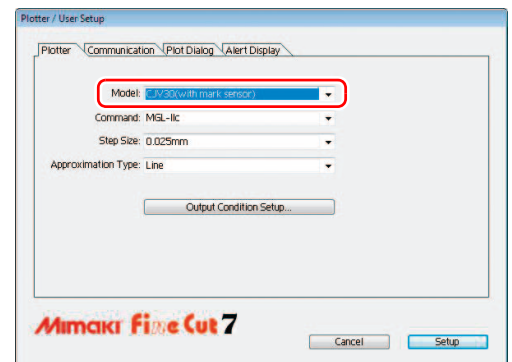

● Prepare FineCut (CoreIDRAW version)

1. Start CoreIDRAW.

2. Check if the FineCut menu is displayed.

- If FineCut is installed properly, FineCut menu is displayed.
- For installation, refer to [P.6 of FineCut Operation Manual](#).

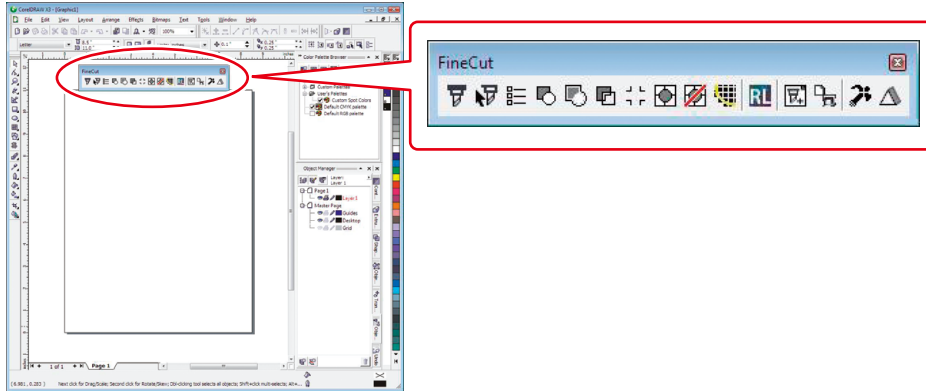

- “FineCut Command Bars” is displayed automatically. If “FineCut Command Bars” is not displayed, select [FineCut] Command Bars from the [Tools]-[Customization] menu in the CoreIDRAW.

3. Click the [Plotter/User Setup] button in FineCut menu.

- The Plotter/User Setup screen is displayed.



4. Select [CJV30] as the plotter type.

- For details, refer to [P.99 of FineCut Operation Manual](#).
- When creating a seal/a sticker continuously, proceed to [P. 11 “When using Illustrator \(FineCut\)”](#).

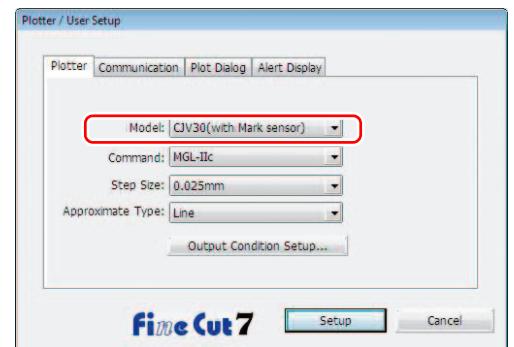

● Prepare SimpleStudio.

1. Check if SimpleStudio is installed.

- If it is installed, the icon on the right is displayed on the PC desktop.
- For installation, refer to [Chapter1 of SimpleStudio Operation Manual](#).



2. Double-click to start SimpleStudio.

- When starting SimpleStudio for the first time after installation, operate the followings:
 - (1) The dialog to enter the product key is displayed. Enter the product key on the CD case of SimpleStudio.
 - (2) The dialog of [Plotter setting] is displayed. Click [OK].



- When cutting is performed from SimpleStudio directly, to select plotter is required. Refer to [P.56 of SimpleStudio Operation Manual](#).
 - If you create a seal/ a sticker continuously, proceed to [P.15 「When using SimpleStudio」](#) .
-

Let's create a seal/a sticker

Let's create a seal/a sticker using a sample image including in the CD of CJV30 Operation Manual.

When using Illustrator (FineCut)

Important!

- Check [P. 2 to P. 7](#) “**First, confirm the following items:**” without fail before creating a seal/a sticker.

1. Double-click to start RasterLinkPro4 SG.

- The main window of RasterLinkPro4 SG is displayed.

2. Set the CD of CJV30 Operation Manual into the disk drive.



3. Click [Print & Cut Manual / Sample data].

4. Double-click “sample1.eps”.

- Illustrator will start automatically, and “sample1.eps” is opened.

5. Click the image.

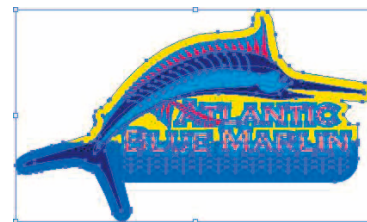

6. Click the [Frame Extraction] button of FineCut.

- Create the cutting line with the [Frame Extraction] button.

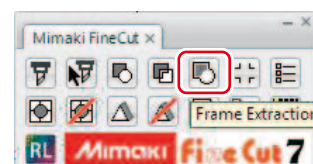

7. Set the flame size.

- Set the size of the flame (cutting line) applied around the illustration.
- For details of setting flame, refer to [P.58 of FineCut Operation Manual](#).

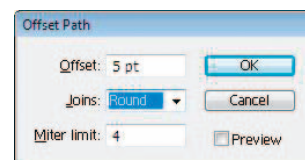

8. Click [OK].

- The flame (cutting line) is created in “FC frame layer”.
- **After creating the flame (cutting line), then create a register mark as a guide for cutting seal/sticker.**



9. Create the frame of the register mark using “Rectangle Tool” of Illustrator.

- When creating data with register marks, there are some restrictions. Create it referring to [P4-6 to 10 of CJV30 Operation Manual](#).

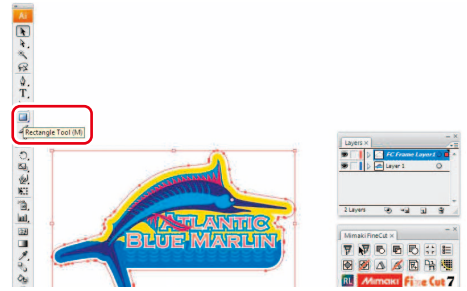

10. Click the [Register Mark Creation] button of FineCut.

- The Register Mark Creation dialog is displayed.



11. Click [OK].

- The register mark is created in “FC Register Mark Layer”.

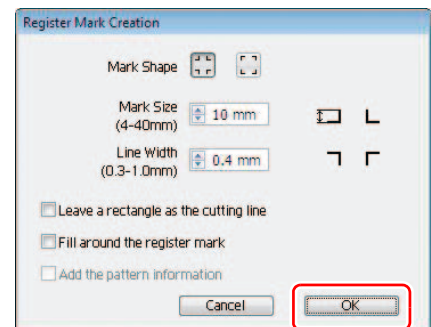

12. Click the [Output to Raster Link] button of FineCut.

- [Output to Raster Link] dialog box is displayed.



13. Click [Select Hot Folder...].

14. Select the hot folder of CJV30.

- Select the folder created in [P. 7 “Prepare RasterLinkPro4 SG.”](#) from [RasterLinkPro4] - [Hot].

15. Check the print layer/the cut layer and contents of each setting.

16. Click [Output], and then click [OK].

- For each setting, refer to FineCut Operation Manual.
- The print data and the cut data will be sent to RasterLinkPro4 SG.
- Terminate Illustrator.
- Subsequently, the work in RasterLinkPro4 SG is required. Proceed to [P. 19 “Print&Cut in RasterLinkPro4 SG”](#).

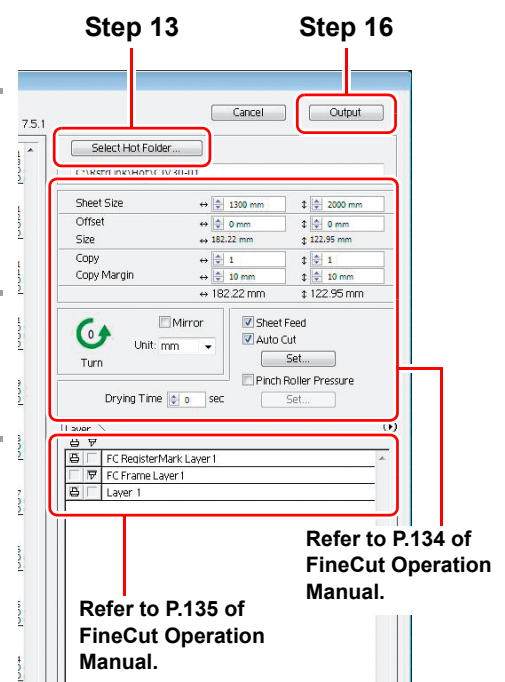

When using CorelDRAW (FineCut)

Important!

- Check [P. 2 to P. 7](#) “**First, confirm the following items:**” without fail before creating a seal/a sticker.

1. Double-click to start RasterLinkPro4 SG.

- The main window of RasterLinkPro4 SG is displayed.

2. Set the CD of CJV30 Operation Manual into the disk drive.

3. Click [Print & Cut Manual / Sample data].

4. Double-click “sample2.cdr”.

- CorelDRAW will start automatically, and “sample1.eps” is opened.



5. Click the image.



6. Click the [Frame Extraction] button of FineCut.

- Create the cutting line with the [Frame Extraction] button.

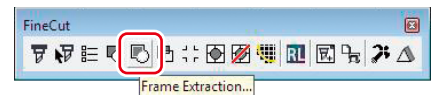

7. Set the flame size.

- Set the size of the flame (cutting line) applied around the illustration.
- For details of setting flame, refer to [P.49 of FineCut Operation Manual](#).

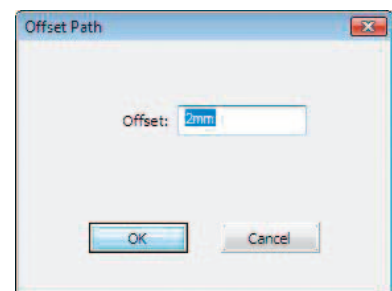

8. Click [OK].

- The flame (cutting line) is created in “FC frame layer”.
- After creating the flame (cutting line), then create a register mark as a guide for cutting seal/sticker.

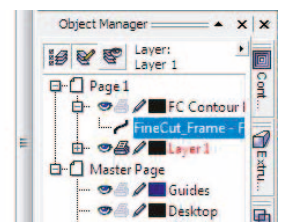

9. Create the flame of the register mark using “Rectangle Tool” of CoreIDRAW.

- When creating data with register marks, there are some restrictions. Create it referring to [P4-6 to 10 of CJV30 Operation Manual](#).

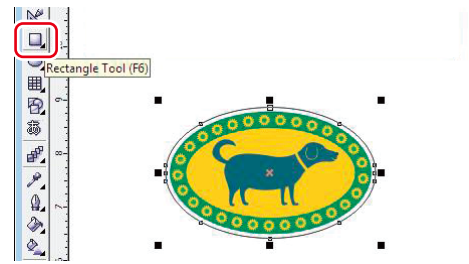

10. Click the [Register Mark Creation] button of FineCut.

- The Register Mark Creation dialog is displayed.



11. Click [OK].

- The register mark is created in “FC Register Mark Layer”.

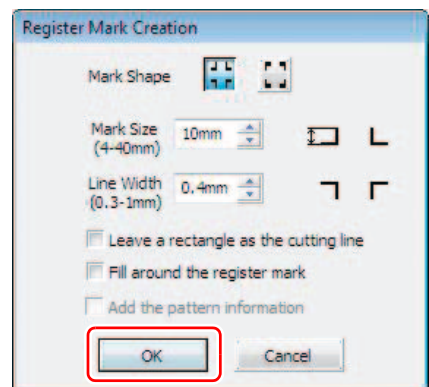

12. Click the [Output to Raster Link] button of FineCut.

- “Output to RasterLink” dialog box is displayed.



13. Click [Select Hot Folder...].

14. Select the hot folder of CJV30.

- Select the folder created in [P. 7 “Prepare RasterLinkPro4 SG.”](#) from [RasterLinkPro4] - [Hot].

15. Check the print layer/the cut layer and contents of each setting.

16. Click [Output], and then click [OK].

- For each setting, refer to FineCut Operation Manual.
- The print data and the cut data will be sent to RasterLinkPro4 SG.
- Terminate Illustrator.
- Subsequently, the work in RasterLinkPro4 SG is required. Proceed to [P. 19 “Print&Cut in RasterLinkPro4 SG”](#).

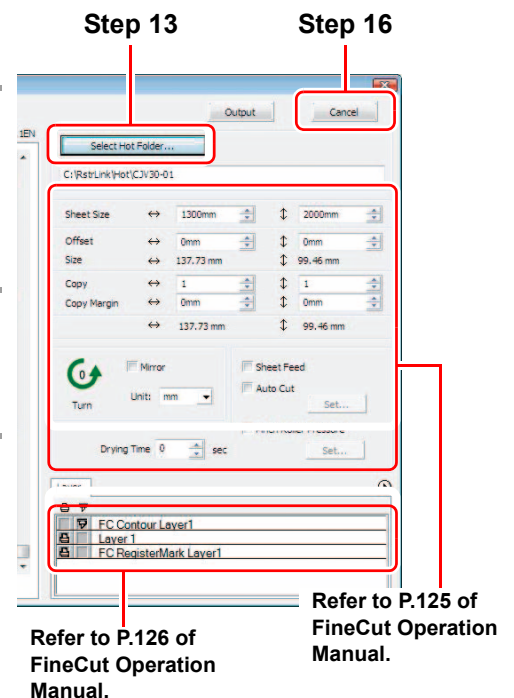

When using SimpleStudio

Important!

- Check **P. 2 to P. 7** “**First, confirm the following items:**” without fail before creating a seal/a sticker.

1. Double-click to start RasterLinkPro4 SG.

- The main window of RasterLinkPro4 SG is displayed.

2. Set the CD of CJV30 Operation Manual into the disk drive.

3. Click [Print & Cut Manual / Sample data].

4. Copy and paste “sample3.jpg” onto the desktop.



5. Double-click to start SimpleStudio.

6. Open [Print] tab and click Import.

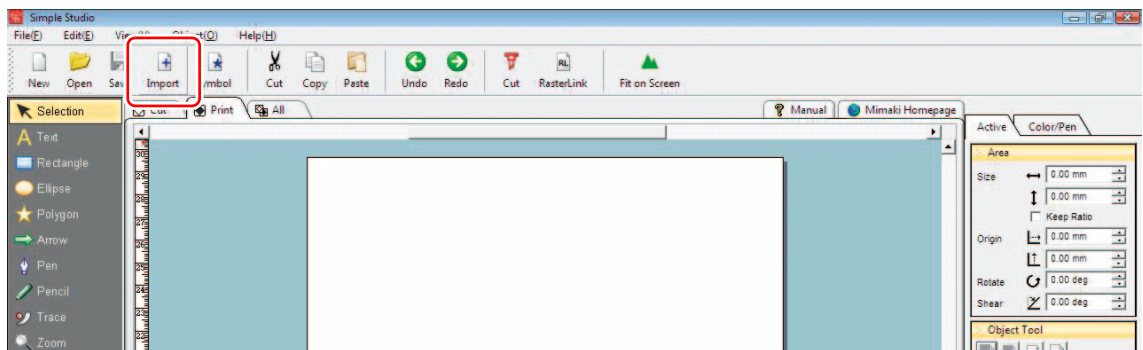

7. Select “sample3” pasted onto the desktop and click [Open].

- Make [Files of type] to “JPEG”.

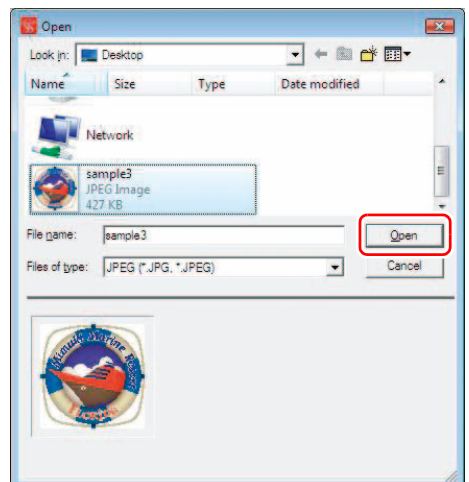

8. Select [All] tab to create a quadrangle using quadrangle drawing tool.

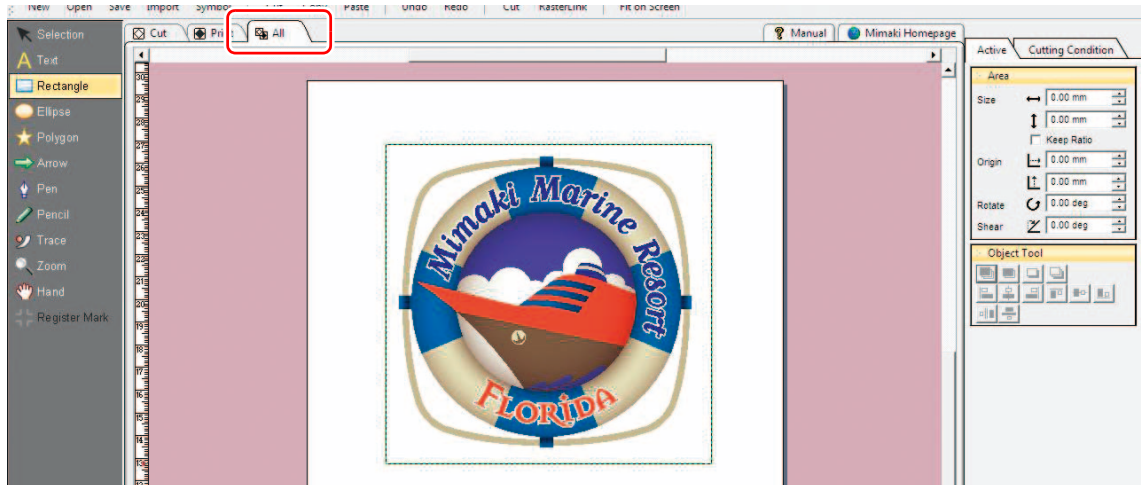

- The quadrangle created here will be the flame (cutting line). The quadrangle will be reflected on [Cut] tab automatically.
- After creating the flame (cutting line), create a register mark used as a guide when cutting a seal/a sticker.

9. Copy the quadrangle created in Step 8 to the print data.

- It is required to copy the flame (cutting line) created in Step 8 onto the print data in order to use it as a guide when creating a register mark.

- (1) Select the quadrangle from [All] tab and right-click it.
- (2) Select [Copy] from [Change to Print Data].

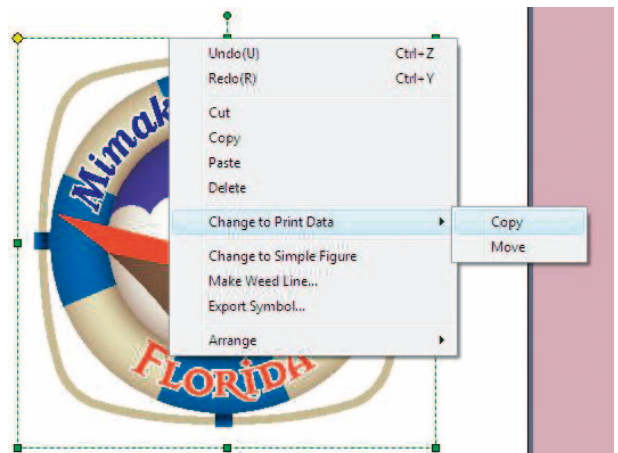

10. Open [Print] tab and click Register Mark.

- When creating data with register marks, there are some restrictions. Create it referring to [P4-6 to 10 of CJV30 Operation Manual](#).

11. Determine the range of the register mark surrounding the quadrangle created in Step 8.



12. Delete the quadrangle copied and pasted onto [Print] tab.

- If you want to print the quadrangle, this Step is not required. Proceed to Step 13 directly.
- (1) Select the register mark created in Step 11.
- (2) Right-click it and select [Arrange] - [Send to Back].
- (3) Select the quadrangle created in Step 8 and press the [Delete] key to delete.

13. Check the contents of [Cut] tab/[Print] tab.

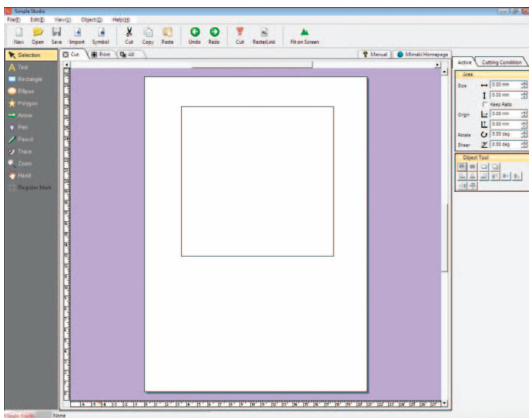

<Cut>

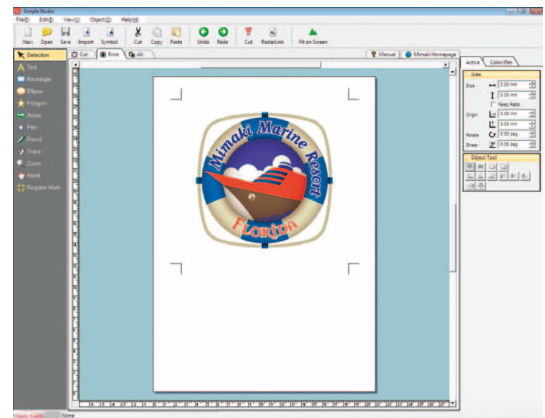

<Print>

14. Click [Raster Link].

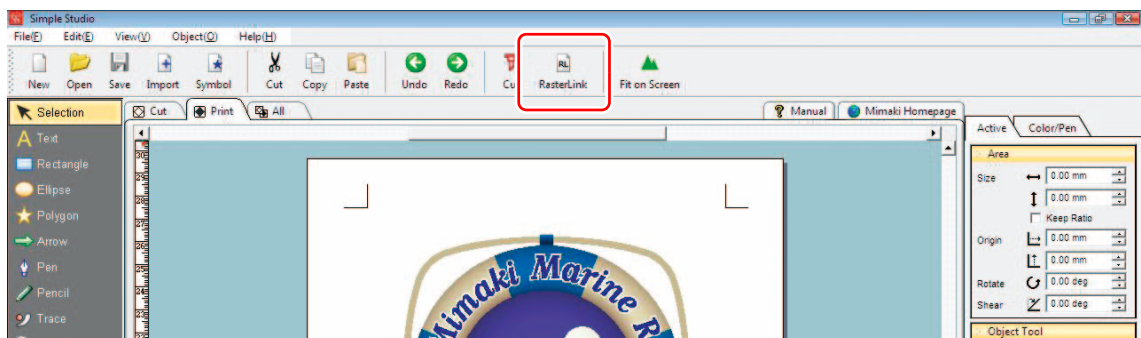
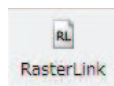

15. Click [Output].

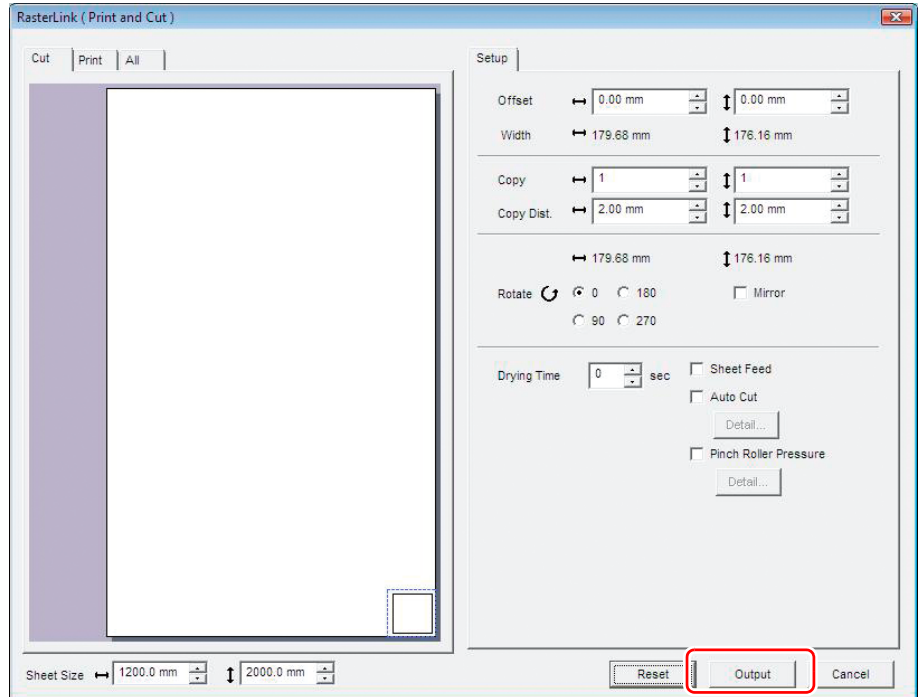

16. Select the hot folder of CJV30.

- From [RasterLinkPro4] - [Hot], select the folder created in [P. 7 "Prepare RasterLinkPro4 SG."](#)

17. Click [OK].

- Print data and cut data will be sent to RasterLinkPro4 SG.
- When outputting is completed, terminate SimpleStudio.
- Subsequently, the work in RasterLinkPro4 SG is required.
Proceed to [P. 19 "Print&Cut in RasterLinkPro4 SG"](#).

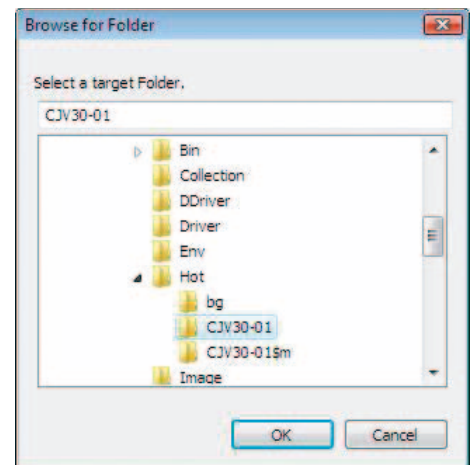

Important!

- When using an imported image other than sample images, import an image whose color mode is RGB. If CMYK image is imported, it is not displayed normally in SimpleStudio.

Print&Cut in RasterLinkPro4 SG

1. Double-click the data to Print&Cut on the main window of RasterLinkPro4 SG.

- Job editor is displayed. Check the following each item:
When performing setting in each item, refer to [Reference Guide of RasterLinkPro4 SG](#) for details.

(1) Click [Image Edit] tab and operate copy etc.

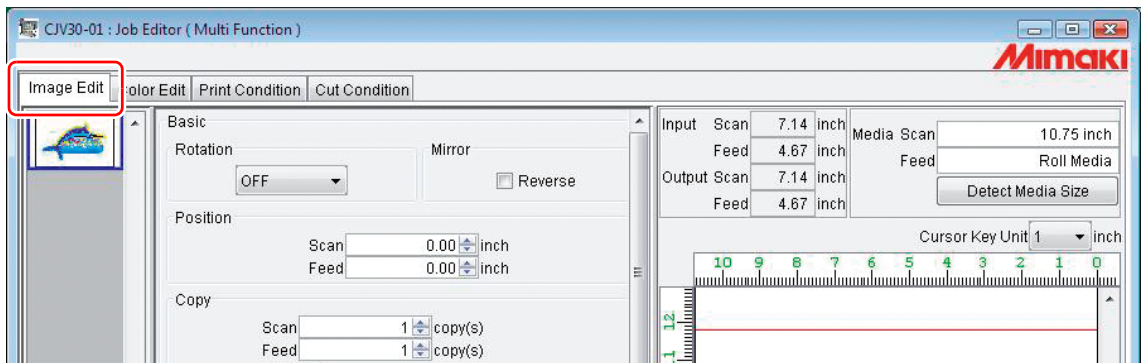

(2) Click [Print Condition] tab and select the profile suited to ink set in CJV30.

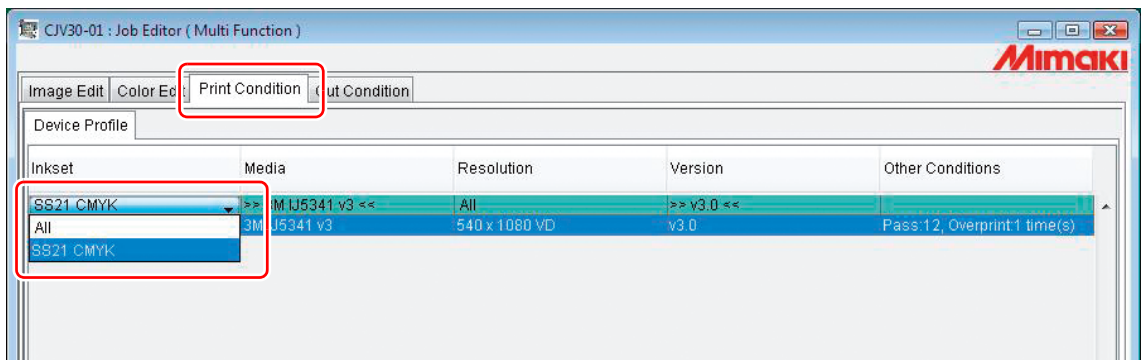

(3) Click [Cut Condition] tab and perform the required setting when cutting a seal.

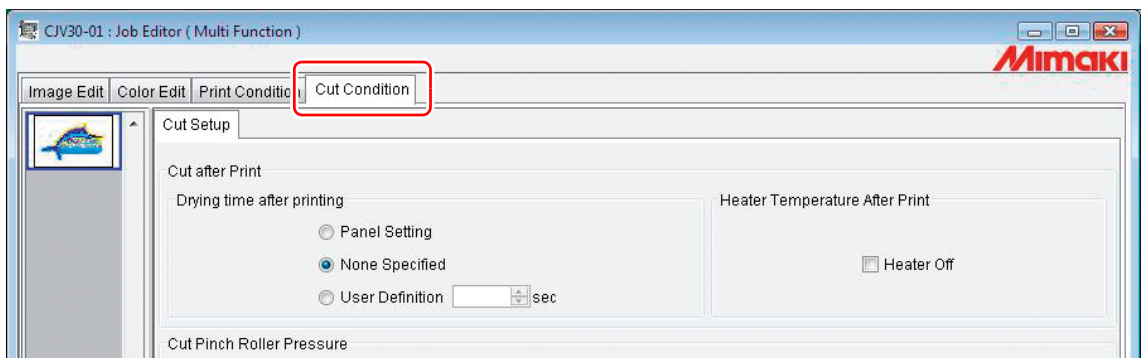

(4) When the required setting is completed, click [OK].

2. Perform Print&Cut.

- (1) Right-click the data to Print&Cut.
- (2) Select [Cut] - [Cut after Immediate Print].

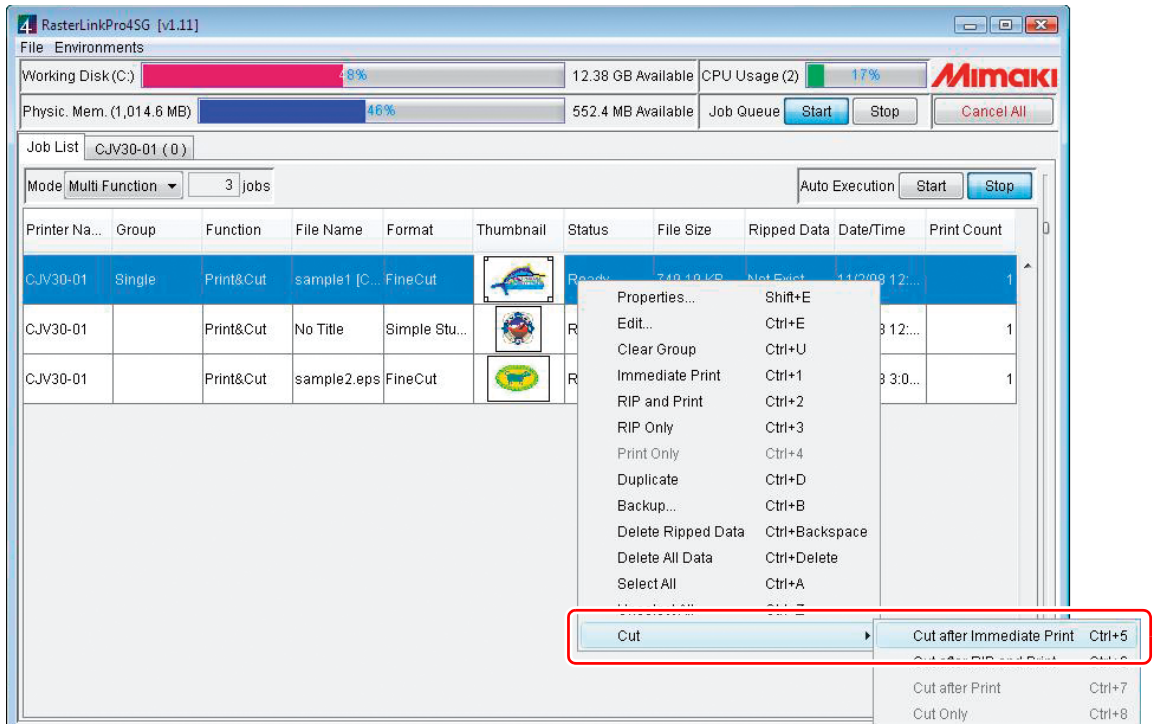

- When changing the medium in CJV30, perform the followings:
 1. Select “CJV30-01” tab on the main window.
 2. Select [Media] tab and click [Update to Current Status].

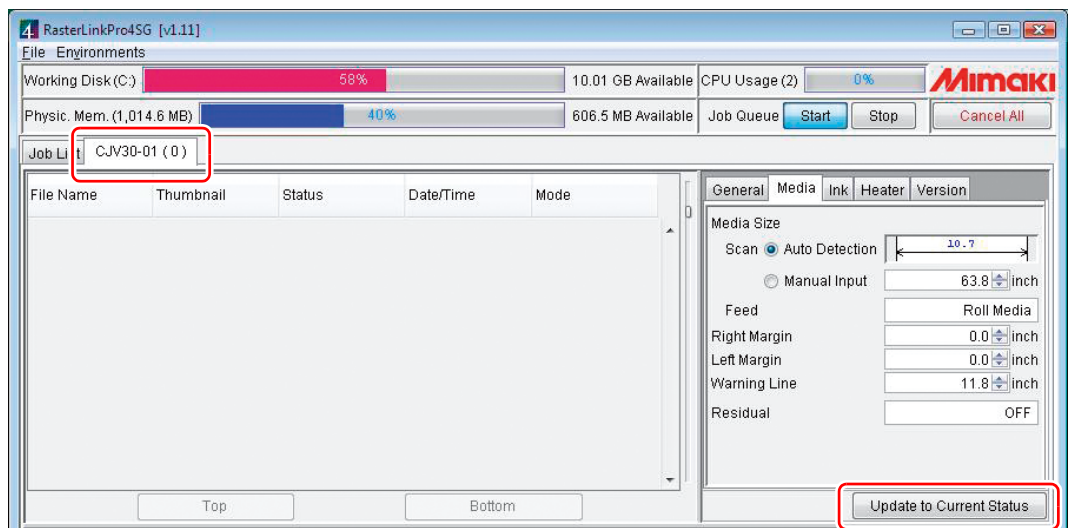

- Only specifying the output in FineCut or SimpleStudio enables Print&Cut. Select [Start] from “Auto Execution” in the main window.

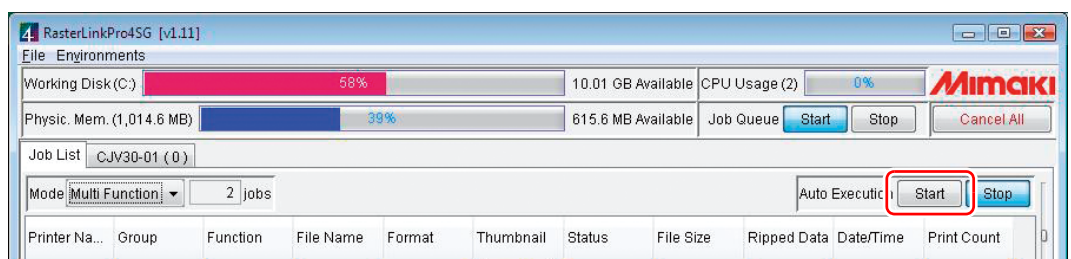

Mimaki