

OPERATION MANUAL

COLOR INKJET PRINTER

SWJ-320 S2
SWJ-320 S4

OPERATION MANUAL



MIMAKI ENGINEERING CO., LTD.

URL: <http://eng.mimaki.co.jp/>

TABLE OF CONTENTS

CAUTION	v
DISCLAIMER OF WARRANTY	v
Requests	v
FCC Statement (USA)	v
Foreword	vi
About usable ink	vi
On This Operation manual	vi
Safety Precautions	vii
Symbols	vii
Pay attention to the electric shock	x
Pay attention to the pinching or catching	xi
Stop switch	xi

Chapter 1 Before Use

Moving This Machine	1-2
Where to Install This Machine	1-2
Working Environmental Temperature	1-2
Moving This Machine	1-3
Names of Parts and Functions	1-4
Front Side of the Machine	1-4
Rear Side and Right Side of the Machine	1-5
Operation Panel	1-6
Heater	1-7
Carriage	1-7
Capping station	1-8
Pinch rollers and Feed rollers	1-8
Lighting inside the unit	1-8
Connecting Cables	1-9
Connecting USB2.0 Interface Cable	1-9
Connecting the power cable	1-10
Ink bottle replacement and charging	1-11
Caution in handling of ink bottles	1-12
Media	1-13
Usable sizes of media	1-13
Caution in handling of medias	1-13
Print Head	1-14
About print head	1-14
Note for handling print head	1-14
To keep print head status	1-14

Chapter 2 Basic Operations

Workflow	2-2
Turning the Power ON/OFF	2-3
Turning the Power ON	2-3
Turning the Power OFF	2-4
Setting a Media	2-5
Note for media setting	2-5
Setting a roll media	2-5
Setting a narrow roll media	2-10

Adjusting the Head Height	2-14
Setting the printing area	2-17
Setting leaf media	2-18
Changing the printing origin	2-19
Preparing for the Heaters	2-20
Setting the heater	2-20
Setting the adsorption fan	2-21
Setting the drying fan	2-22
If ruck is generated on the printing surface of the media	2-22
Test Printing	2-23
Test Printing	2-24
Head Cleaning	2-25
About head cleaning	2-25
Perform head cleaning depending on the test printing result	2-25
Set the media feeding	2-26
Setting Feed Correction	2-26
Checking the media feeding amount deviation during printing	2-28
Setting Feed Check Pattern	2-28
Aligning the Print Result Lengths	2-30
Setting Feed Check Pattern	2-30
Correct the ink drop position for bidirectional printing	2-32
Printing Data	2-34
Starting a Printing Operation	2-34
Stopping a printing operation halfway	2-35
Deleting Received Data (Data Clear)	2-35
Using method of weight for assistant roller	2-36

Chapter 3 Extended Functions

List of Functions	3-2
Setting Logical Seek	3-3
Setting Drying Time	3-4
Perform setting to reduce stripes between passes	3-5
Setting Auto Cleaning	3-7
Setting nozzle face cleaning time	3-8
Set the scanning speed and the feeding speed during printing	3-9
Other Settings	3-11
Machine Settings	3-12
Setting a AUTO Power-off	3-13
Setting the Display of Media Residual	3-14
Setting the Feed Compensation Mode	3-16
Setting Time	3-17
Setting Units	3-18
Setting a KEY BUZZER	3-19
Setting a LANGUAGE	3-20
Initializing the Settings	3-21
Confirming Machine Information	3-22

Displaying the Information	3-22
Displaying the Information of this machine	3-23

Chapter 4 Maintenance

Maintenance	4-2
Precautions for Maintenance	4-2
About Cleaning Solution	4-2
Cleaning the Exterior Surfaces	4-3
Cleaning the Platen	4-3
Cleaning of after heater cover and pre heater cover	4-3
Cleaning the Media Holder	4-4
Maintaining the Capping Station	4-5
Cleaning the Wiper and Cap	4-5
Washing the Ink Discharge Passage (DISWAY WASH) ..	4-8
When the Machine Is Not Used for a Long Time (CUSTODY WASH)	4-9
Cleaning the Ink Head and the Area around It	4-12
When Nozzle Clogging Cannot Be Solved	4-14
Ink purge	4-14
Washing of Head nozzle	4-16
Alternative nozzles for printing, when nozzles missing can not be improved	4-18
Automatic Maintenance Function	4-25
Setting the Refreshing Intervals	4-25
Setting the Cleaning Intervals	4-26
Replacing consumables	4-27
Replacing the wiper	4-27
Replace the waste ink tank with another	4-28
Replacing the fan filter	4-29

Chapter 5 Troubleshooting

Troubleshooting	5-2
Power does not turn on	5-2
The machine does not start printing	5-2
Media get jammed / media is soiled	5-3
Image quality is poor	5-3
Nozzle is clogged	5-4
When media heaves up at feeding	5-4
Warning / Error Messages	5-5
Warning messages	5-5
Error messages	5-8

Chapter 6 Appendix

Specifications	6-2
Machine specifications	6-2
Ink specifications	6-3
Warning labels	6-4
Sheet for inquiry	6-6
Function Flowchart	6-8

DISCLAIMER OF WARRANTY

THIS LIMITED WARRANTY OF MIMAKI SHALL BE THE SOLE AND EXCLUSIVE WARRANTY AND IS IN LIEU OF ALL OTHER WARRANTIES, EXPRESS OR IMPLIED, INCLUDING, BUT NOT LIMITED TO, ANY IMPLIED WARRANTY OF MERCHANTABILITY OR FITNESS, AND MIMAKI NEITHER ASSUMES NOR AUTHORIZES DEALER TO ASSUME FOR IT ANY OTHER OBLIGATION OR LIABILITY OR MAKE ANY OTHER WARRANTY OR MAKE ANY OTHER WARRANTY IN CONNECTION WITH ANY PRODUCT WITHOUT MIMAKI'S PRIOR WRITTEN CONSENT.

IN NO EVENT SHALL MIMAKI BE LIABLE FOR SPECIAL, INCIDENTAL OR CONSEQUENTIAL DAMAGES OR FOR LOSS OF PROFITS OF DEALER OR CUSTOMERS OF ANY PRODUCT.

Requests

- This Operation manual has been carefully prepared for your easy understanding. However, please do not hesitate to contact a distributor in your district or our office if you have any inquiry.
- Description contained in this Operation manual are subject to change without notice for improvement.

FCC Statement (USA)

Not supported.

Foreword

Congratulations on your purchase of MIMAKI color ink jet printer "SWJ-320S" .
"SWJ-320S" is a color inkjet printer that can print on 3.2m-width media (tarpaulin/FF/polyvinyl chloride film) with solvent ink realizing high image quality.

About usable ink

Usable ink for this machine is CS ink (four-color model).

4-colors version:Each one ink bottle of Cyan, Magenta, Yellow and Black is useable.

On This Operation manual

- This Operation manual is describing the operations and maintenance of "Color inkjet printer SWJ-320S" (called as this machine hereafter)
- Read this Operation manual carefully and understand them thoroughly to use.
- It is also necessary to keep this Operation manual on hand.
- This Operation manual has been carefully prepared for your easy understanding, however, please do not hesitate to contact a distributor in your district or our office if you have any inquiry.
- Descriptions contained in this Operation manual are subject to change without any notice for improvement.
- In the case when this Operation manual should be illegible due to destruction or lost by fire or breakage, purchase another copy of the Operation manual from our office.
- You can also download the latest manual from our website.











Reproduction of this manual is strictly prohibited.
All Rights Reserved.Copyright
© 2015 MIMAKI ENGINEERING Co., Ltd.

Safety Precautions





Symbols

Symbols are used in this Operation Manual for safe operation and for prevention of damage to the machine. The indicated sign is different depending on the content of caution. Symbols and their meanings are given below. Please follow these instructions as you read this manual.









Examples of symbols

Meaning	
	Failure to observe the instructions given with this symbol can result in death or serious injuries to personnel. Be sure to read it carefully and use it properly.
	Failure to observe the instructions given with this symbol can result in injuries to personnel or damage to property.
	Important notes in use of this machine are given with this symbol. Understand the notes thoroughly to operate the machine properly.
	Useful information is given with this symbol. Refer to the information to operate the machine properly.
	Indicates the reference page for related contents.
	The symbol "  " indicates that the instructions must be observed as strictly as the CAUTION instructions (including DANGER and WARNING instructions). A sign representing a precaution (the sign shown at left warns of hazardous voltage) is shown in the triangle.
	The symbol "  " indicates that the action shown is prohibited. A sign representing a prohibited action (the sign shown at left prohibits disassembly) is shown in or around the circle.
	The symbol "  " indicates that the action shown must be taken without fail or the instructions must be observed without fail. A sign representing a particular instruction (the sign shown at left instructs to unplug the cable from the wall outlet) is shown in the circle.

Warning for Use

 WARNING	
	<ul style="list-style-type: none"> • Do not use the machine in a poorly ventilated room or a closed room. • Be sure to use the optional Rear fan when the machine is used in a poorly ventilated room or a closed room. • Use the attached power cable. • Take care not to damage, break or work upon the power cable. If a heavy material is placed on the power cable, or if it is heated or pulled, the power cable can break, thus resulting in fire or electric shocks. • Avoid locating the machine in a damp environment. Do not splash water onto the machine. Use in such an environment can give rise to fire, electric shocks or breakdown of the machine. • Use of the machine under an abnormal condition where it produces smoke or strange smell can result in fire or electric shocks. If such an abnormality is found, be sure to turn off the power switch immediately and unplug the cable from the wall outlet. Check first that the machine no longer produces smoke, and then contact your distributor or a sales office of MIMAKI for repair. • Never repair your machine by yourself since it is very dangerous for you to do so. • Never disassemble or remodel the main unit of the machine or the ink bottle. Disassembly or remodeling can result in an electric shock or breakdown of the machine. • Take care that no dust or dirt sticks to platen heaters. Dust and dirt sticking heaters can cause fire.
	<ul style="list-style-type: none"> • The ink used for this machine contains organic solvent. Since the ink is flammable, never use flame in or around the place where this machine is used.
	<p>Hazardous Moving Parts Keep Fingers and Other Body Parts Away</p>

Precautions in Use



 CAUTION	
Power supply	Handling of ink
	
<ul style="list-style-type: none"> • Do not turn off the main power switch on the right side of this machine. 	<ul style="list-style-type: none"> • If you get ink in your eyes, immediately wash your eyes with a lot of clean water for at least 15 minutes. In doing so, also wash eyes to rinse ink away completely. Then, consult a doctor as soon as possible. • If anyone drinks ink by mistake, keep him or her quiet and see a doctor immediately. Do not allow him or her to swallow the vomit. After that, contact the Poison Control Center. • If you inhale a lot of vapor and feel bad, immediately move to a location of fresh air and then keep yourself warm and quiet. Then, consult a doctor as soon as possible. • The ink contains organic solvent. If ink settles on the skin or clothes, immediately wash it off with detergent and water.
Heater	
	
<ul style="list-style-type: none"> • Do not spill liquid on the platen as this may cause failure of the heater or firing. • Do not touch platen heaters with bare hand while it is hot; otherwise, you can get burned. 	
	
<ul style="list-style-type: none"> • When the machine is to be moved, wait until the heater temperature drops adequately. As a criterion, wait at least 30 minutes after you turn off the power to the heater. Moving the machine must be limited to on the same floor where there is no steps. When the machine is to be moved to any place other than on the same step-free floor, contact your distributor or a sales office of MIMAKI. 	
Note on maintenance	
	<ul style="list-style-type: none"> • Be sure to wear the accessory gloves when cleaning the ink station or head. The accessory goggles are also required to wear.
	

CAUTIONS and NOTES

 Warning	
Handling of ink bottles	Front cover and lever
<ul style="list-style-type: none"> • Use the SWJ-320S genuine ink. Remember that the user shall be filled for a repair to correct any damage resulting from the use of ink other than the exclusive type. • The machine does not operate with any ink other than the SWJ-320S genuine ink. • Do not use the SWJ-320S genuine ink with other printers, as doing so may cause damage to such machines. • Never refill the ink bottle with ink. Refilled ink bottle can cause a trouble. Remember that MIMAKI assumes no responsibility for any damage caused by the use of the ink bottle replenished with ink. • If the ink bottle is moved from a cold place to a warm place, leave it in the room temperature for 24 hours or more before using it. • Open the ink bottle just before installing it in the machine. If it is opened and left for an extended period of time, normal printing performance of the machine may not be ensured. • Make sure to store ink bottles in a cool and dark place. • Store ink bottles and waste ink tank in a place that is out of the reach of children. • Be sure to thoroughly consume the ink in the ink bottle, once it is opened, within three months. If an extended period of time has passed away after opening the ink bottle, printing quality would be poor. • Neither pound the ink bottle nor shake it violently. • Do not touch or stain the contacts of the ink IC chip, as doing so may cause damage to the print circuit board. • Waste ink is equivalent to waste oil of industrial waste. Request an industrial waste disposal company for disposal of waste ink. 	<ul style="list-style-type: none"> • Never open the front cover or raise the lever during printing. Opening the cover or raising the lever will abort printing.
	Handling of media
	<ul style="list-style-type: none"> • Use media recommended by MIMAKI to ensure reliable, high-quality printing. • Set the heater temperature to meet the characteristics of the media. Set the temperature of the Pre-heater, Print heater and Post-heater according to the type and characteristics of the media used. • Pay attention to the expansion and contraction of the media. Do not use media immediately after unpacking. The media can be affected by the room temperature and humidity, and thus it may expand and contract. The media have to be left in the atmosphere in which they are to be used for 30 minutes or more after unpacked. • Do not use curled media. The use of curled media can not only cause a media jam but also affect print quality. Straighten the sheet of media, if significantly curled, before using it for printing. If a regular-sized coated sheet of media is rolled and stored, the coated side has to face outside.
	Protection of media from dust
	<ul style="list-style-type: none"> • Store media in a bag. Wiping off dust accumulated on media will adversely affect the media due to static electricity. • When leaving the workshop after the working hours, do not leave any media on the roll hanger. If any media is left on the roll hanger, it can get dusty.

 Warning	
Notes on maintenance	
<ul style="list-style-type: none"> • It is strongly recommended to use the machine in a room that is not dusty. Set the Refresh level 2 or 3 when the machine is to be used in an unfavorable environment. • Keep the front cover closed even when the machine is not printing. If not, dust can accumulate on the nozzles in the heads. • Dust in the heads can also cause drops of ink to fall suddenly down on the media during printing. In such a case, be sure to clean up the heads. • Be sure to wear gloves and goggles when cleaning the ink station or head. • Perform wiping (removal of dust and paper powder) of the capping station and wiper frequently. 	
Periodic replacement parts	
<ul style="list-style-type: none"> • Some parts of this machine must be replaced with a new one periodically by service personnel. Be sure to make a contract with your distributor or dealer for After sale service to ensure a long life of your machine. 	
Disposition of this machine	
<ul style="list-style-type: none"> • When discarding this machine, request the treatment of it for an industrial waste disposal contractor. • Treat it properly in compliance with regulation in the local area. 	

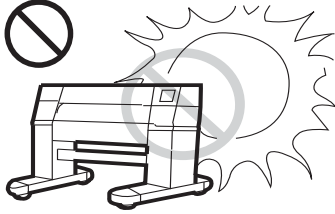
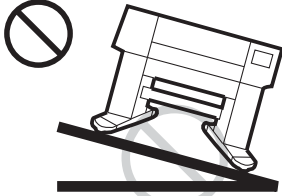
Cautions on Installation

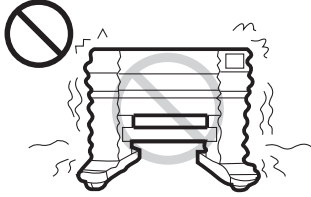
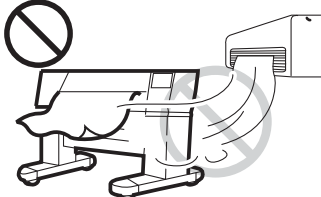
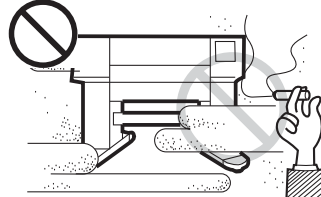
 CAUTION		
A place exposed to direct sunlight	On an inclined surface	A place where temperature or humidity varies significantly
		 <ul style="list-style-type: none"> • Use the machine under the following environmental conditions: • Operating environment: 20 to 35 °C (68 to 95 °F) 35 to 65 % (Rh)
A place that vibrates	A place exposed to direct air flow from an air conditioner or the like.	Around a place where fire is used
		

Pay attention to the electric shock

Be careful not to touch the hot-line parts since the electric shock may happen.

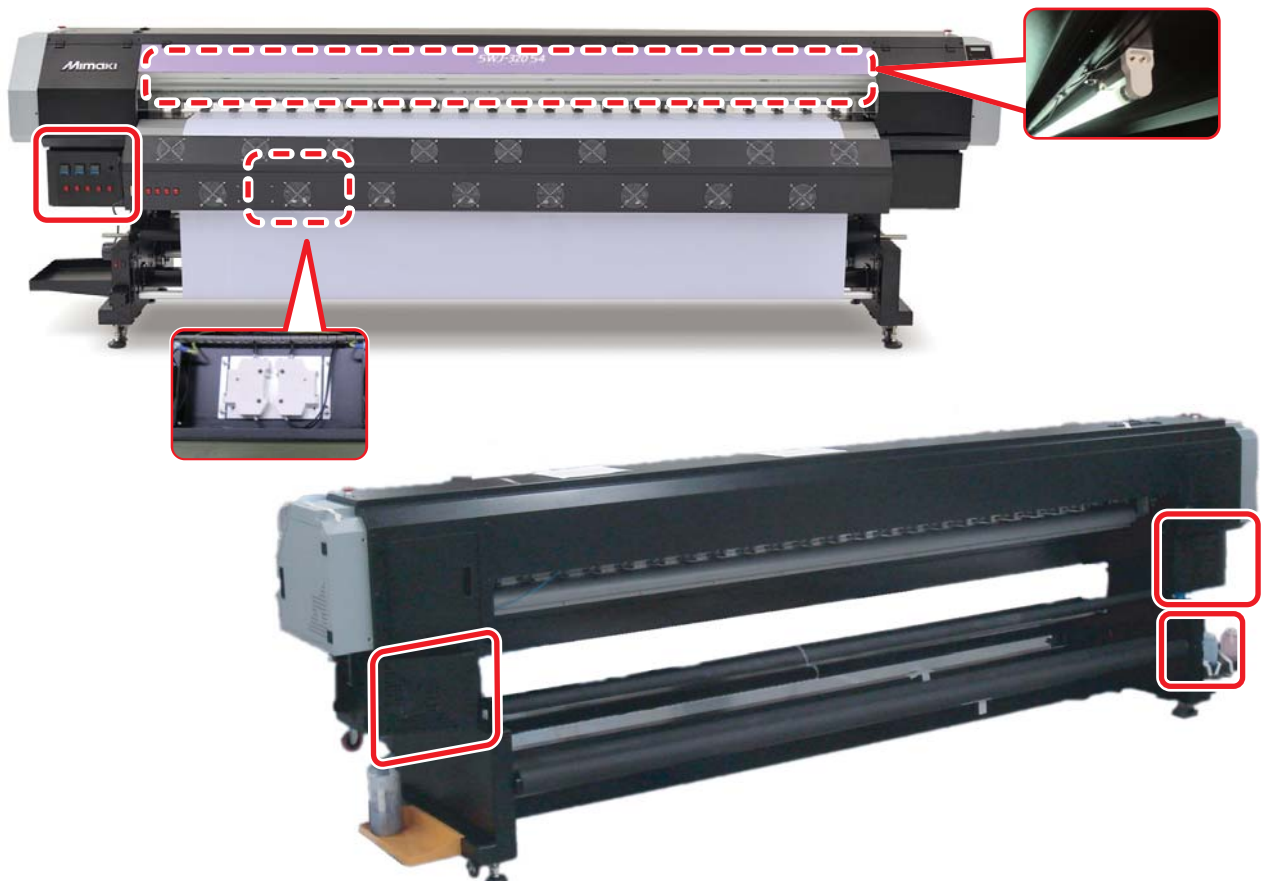

Pay attention to the pinching or catching

① Note the pinching

It may cause to pinch fingers or hands by suddenly closing of cover.

② Note the catching

Keep hands or hair a distance from the driving parts during the operation of this product. It may suffer an injury by pinching hands or twining hair.

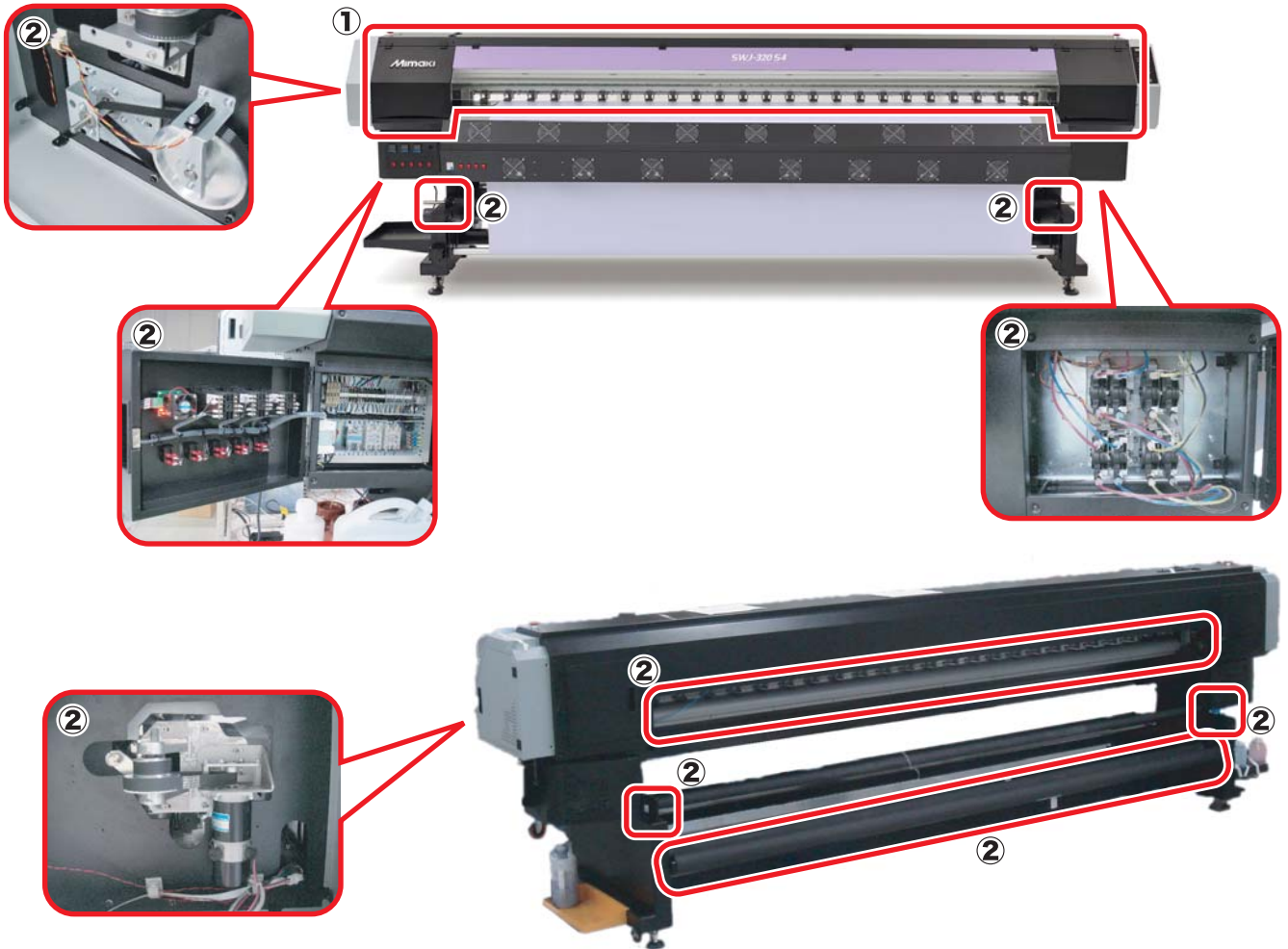

Stop switch

This machine unit equips the stop switch to stop the function emergency, for safety. (red circle parts in the figure below).



Chapter 1

Before Use



This chapter

describes the items required to understand before use, such as the name of each part of the machine or the installation procedures.

Moving This Machine	1-2	Connecting Cables	1-9
Where to Install This Machine	1-2	Connecting USB2.0 Interface Cable	1-9
Working Environmental Temperature	1-2	Connecting the power cable	1-10
Moving This Machine	1-3	Ink bottle replacement and charging	1-11
Names of Parts and Functions	1-4	Caution in handling of ink bottles	1-12
Front Side of the Machine	1-4	Media	1-13
Rear Side and Right Side of the Machine ...	1-5	Usable sizes of media	1-13
Operation Panel	1-6	Caution in handling of medias	1-13
Heater	1-7	Print Head	1-14
Carriage	1-7	About print head	1-14
Capping station	1-8	Note for handling print head	1-14
Pinch rollers and Feed rollers	1-8	To keep print head status	1-14
Lighting inside the unit	1-8		

Moving This Machine

Where to Install This Machine

Secure a suitable installation space before assembling this machine.

The place of installation must have enough space for not only this machine itself, but also for the printing operation.

Width	Depth	Height	Gross weight
4560 mm	1200 mm	1405 mm	650 kg

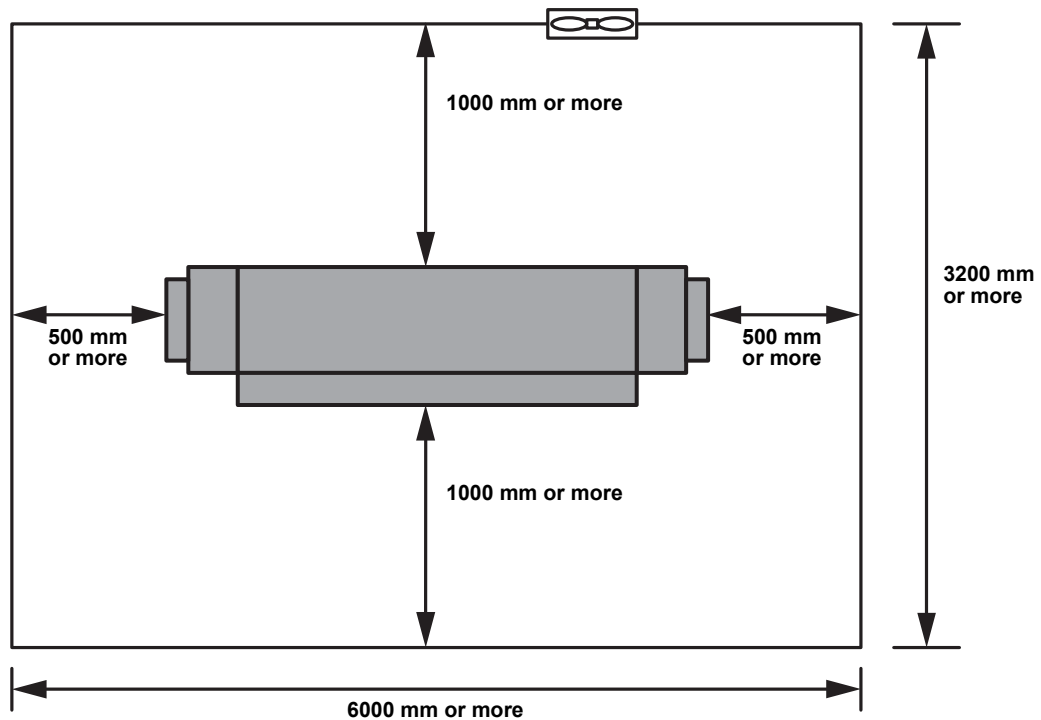

Working Environmental Temperature

Use this machine in an environment of 20 to 30°C to ensure reliable printing.

The heater temperature may not reach the set value, depending on the ambient temperature.

Moving This Machine

Move this machine according to the following steps when this machine needs to be moved on the same step-free floor.

Important!

- When the machine is moved to any place other than on the same step-free floor, contact your distributor or our service office.
If you move it by yourself, failure or damage may occur.
Be sure to request your distributor or our service office to move this machine.



- When moving this machine, take care that it does not receive a significant impact.
- Be sure to lock the caster after moving of this machine.

1

Release the lock of caster.

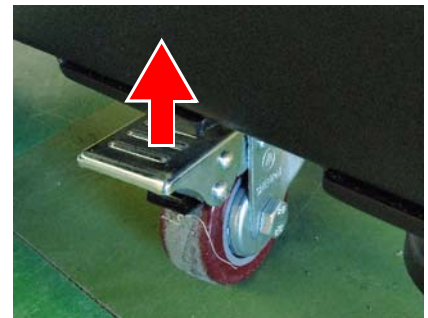

2

Move this machine as shown in the figure.

- For safety, be sure to operate it with 4 people or more.
- Do not push the cover to move this machine since the cover may be broken.



3

Lock the caster.

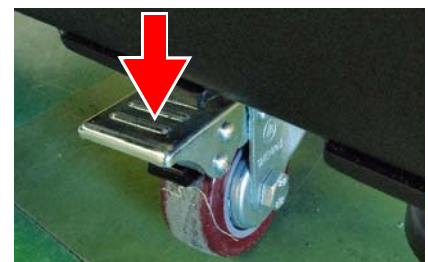

1

Before Use

Names of Parts and Functions

Front Side of the Machine

Left maintenance cover

Open the cover in maintenance.
Even when the power switch is off, keep all covers closed.

Platen

The printed media is sent out, sliding on the platen. Three heaters are installed inside the platen.

Print heater/ Post-heater

Fixes and dries the ink on the currently produced print. (Located inside the platen)

Front cover

Open the cover in setting of medias, taking of measures against jamming of medias or in maintenance inside the station.
Even when the power switch is off, keep this cover and the other covers closed.

Operation panel

This panel has the operation keys required for operating the machine and the LCDs for displaying

Stop switch (L/R)

Stops the operation of carriage immediately.

Right maintenance cover



Drying fan switch

Controls ON/OFF of Drying fan unit.

Take-up device

Take up the output drawn with a roll medium automatically.

Heater panel

Sets the heater temperature of platen and ON/OFF of adsorption fan.

Ink bottle table

Use it to place each color inkbottle.

Drying fan

Blowing fan

Clamp lever

Moves the pinch rollers up and down to hold or release

Stand

Supports the main body of the machine.
Caster for moving and adjuster-foot for fixing are equipped.

Rear Side and Right Side of the Machine

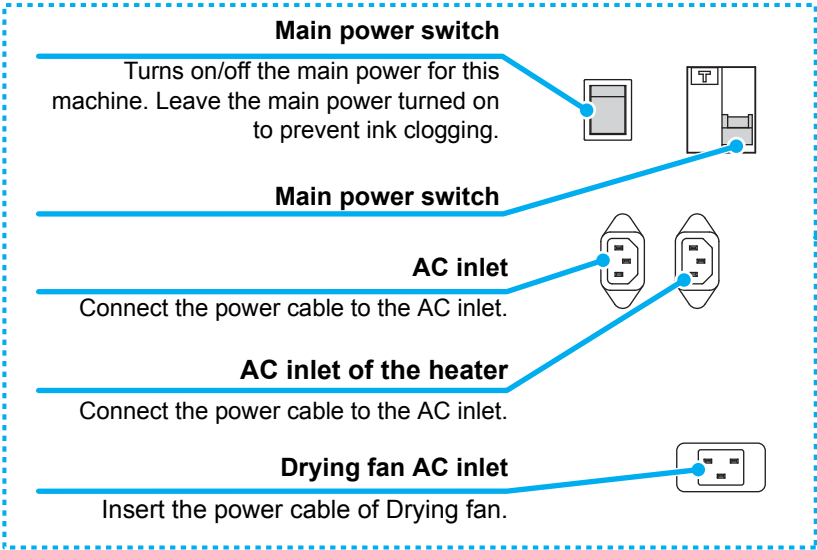

1 Before Use

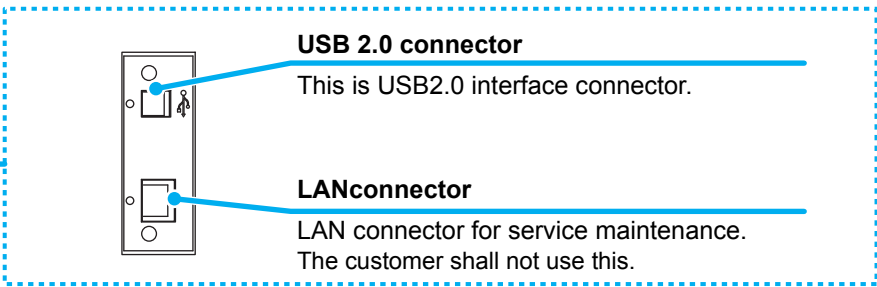
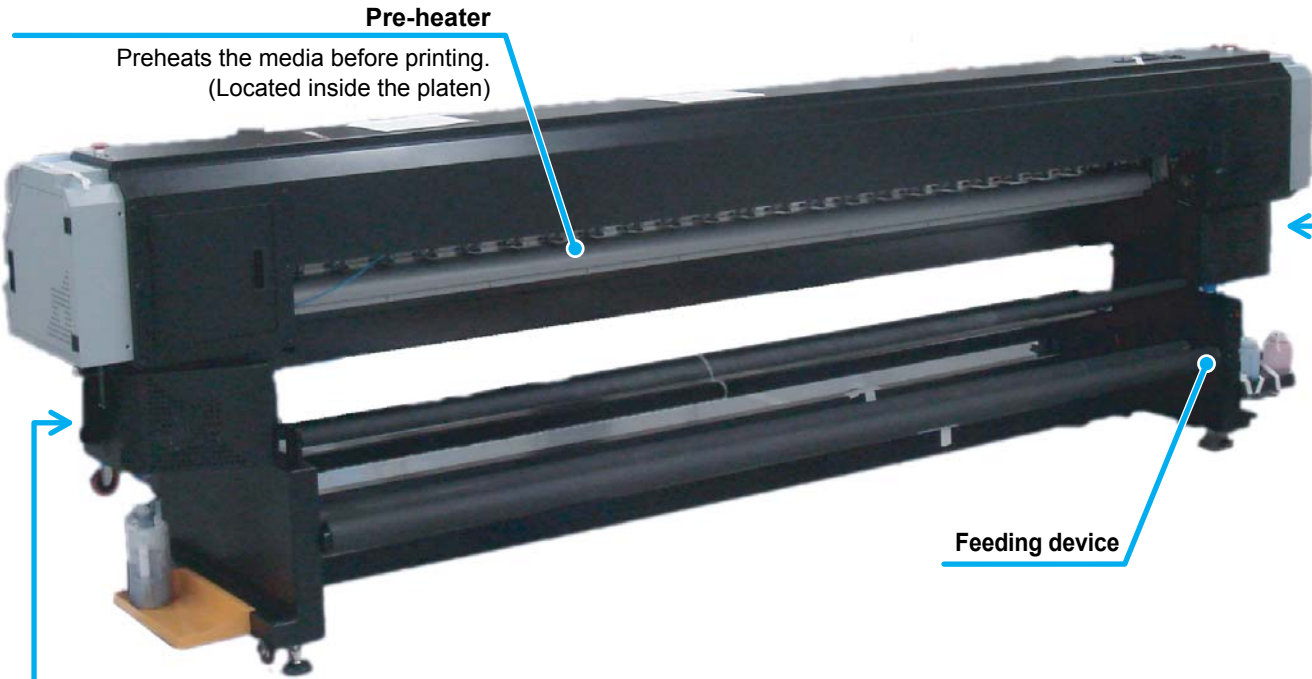

Operation Panel

Use the operation panel to make settings for printing or operate this machine.

Display

Displays the status of the machine, set items and errors.

ACTIVE lamp

Blinks in receiving or drawing data.

ADJUST key

Performs the adjusting function such as "Drop.POScorrect" and "Feed COMP."

MAINT. key

Performs the maintenance function such as station maintenance.

DATA CLEAR key

Deletes the data that have been received.

Ink IC slot

Inserts ink IC chip.

MEDIA SET key

Carry out the print area reset and the head height adjustment function.

TEST PRINT key

Prints test patterns to check whether there are print failures such as ink clogging.

CLEANING key

Executes the cleaning of head in case of ink clogging.

JOG key

Use these keys to shift the carriage or the media in [LOCAL]. Also use them to select an item of printing conditions.

Power switch *1

Turns on/off the power to the machine.

FUNCTION key

Use this key to display function setting menu.

END key

Cancels the last input value or returns the setting menu to the immediate higher level of the hierarchy.

REMOTE key

Use this key to switch between [REMOTE] and [LOCAL].

ENTER key

Registers the last input value as the setting value or goes to the immediate lower level of the hierarchy.

*1 : The power switch under the operation panel lights when the power is turned on, and blinks when the power switch is turned off. The ink clogging prevention function is periodically operated even when the power switch is OFF if the main power switch keeps being ON. (Auto maintenance function)  P.1-5

Heater

Pre-heater/Print heater/Post-heater are equipped on the platen.

The Pre-heater is used for pre-heating of the media prior to printing to prevent rapid changes in temperature. The Print-heater improves the image quality in printing. The Post-heater and drying-heater dries ink after printing.



- While the heater is on, the platen is very hot. When the front cover is to be opened or media is to be replaced, lower the heater temperatures and wait until the platen temperature drops; otherwise, you can get burned.
- When the media is to be replaced with a thin one, lower the heater temperatures and wait until the platen temperature drops adequately. Setting a thin sheet of media while the platen is hot may cause the media to stick to the platen or cause wrinkling or curling of the media.

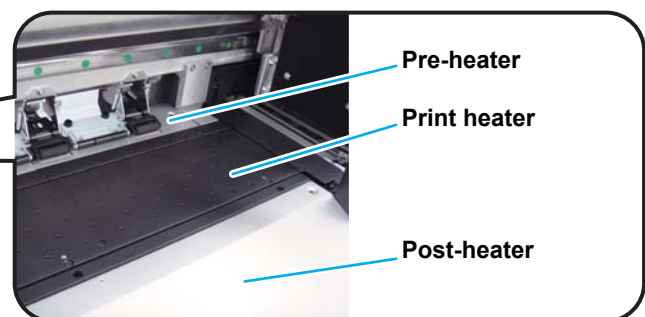
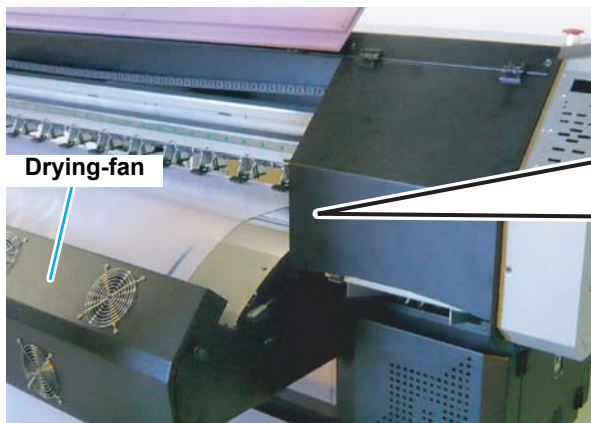

1

Before Use

Carriage

The carriage is provided with the ink heads for printing.

Also, the height adjusting screw adjusting the height of head according to the thickness of media is arranged.

(☞ P.2-14)

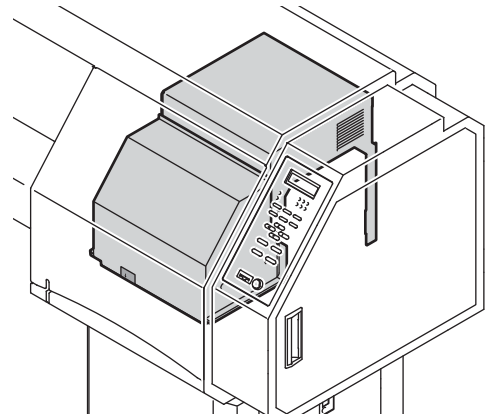

Capping station



- Be sure to wear the attached goggles in cleaning within the capping station to protect your eyes against ink. Otherwise, you may get ink in your eyes.

The capping station consists of the ink caps, the wiper for cleaning the heads, etc.

The ink caps prevent the nozzles in the ink heads from drying up. The wiper cleans the nozzles in the heads.

The wiper is consumable. If the wiper is deformed or the media is stained, replace the wiper with a new one. (☞ P.4-27)

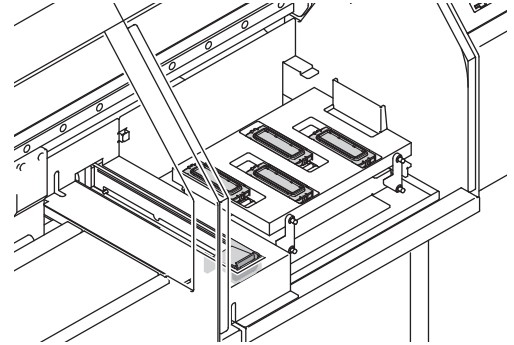

Pinch rollers and Feed rollers

Important!

- Keep the pinch rollers lifted up when this machine is not in use. If the pinch rollers are left lowered for an extended period of time, they can be deformed and fail to securely retain the media.

This machine retains the media with the pinch rollers and feed rollers. During printing operation, the feed rollers feed the media forward.

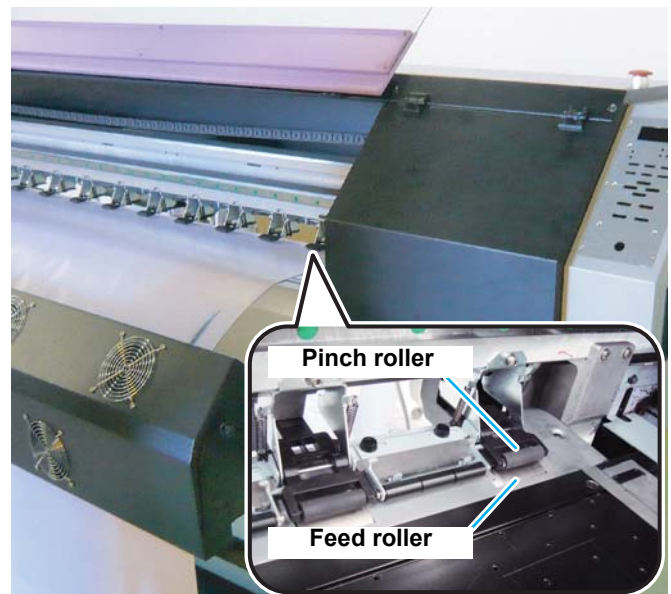

Lighting inside the unit

In this unit, a fluorescent lamp for checking the printing result within the platen and LED for checking the condition of the bottom surface of head at the maintenance of print head are equipped.

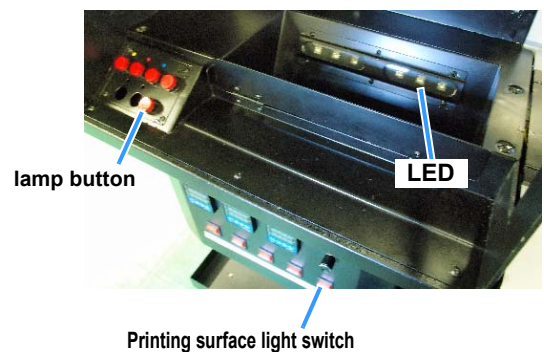

Connecting Cables

Connecting USB2.0 Interface Cable

Connect the PC and this machine with the USB2.0 interface cable.



- Your RIP must be compatible with USB 2.0.
- Contact a RIP maker near your location or our office when the USB2.0 interface is not attached to the PC.

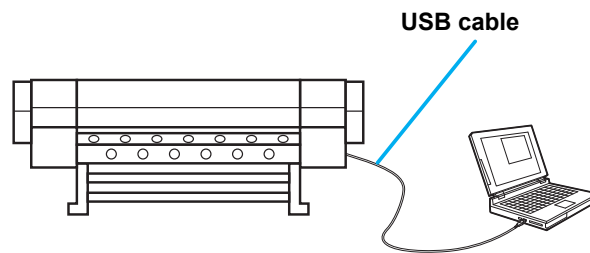

Notes on USB 2.0 Interface



- Your RIP must be compatible with USB 2.0.

● When two or more machines are connected to one personal computer

When two or more SWJ-320S machines are connected to one personal computer, the personal computer may not recognize all the SWJ-320S machines normally.

Reconnect the unrecognized SWJ-320S machine to another USB port, if available, and check to see if it is recognized. If the SWJ-320S machine is not recognized by the newly connected USB port, use USB 2.0 repeater cables available on the market.

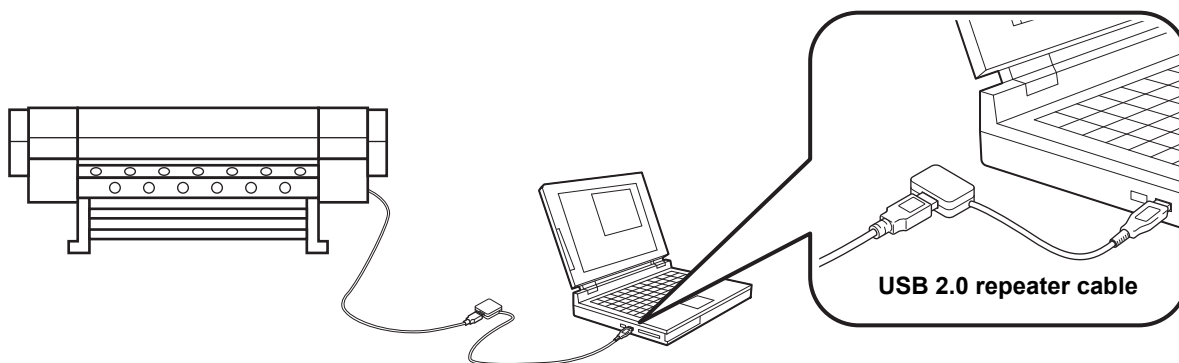

● Notes on peripheral devices in USB high speed mode

When a peripheral device (USB memory or USB HDD) to be operated in USB high speed mode is connected to the same personal computer that a SWJ-320S machine is connected to, the USB device may not be recognized.

When SWJ-320S is connected to the personal computer to which an external HDD is connected via USB, the speed of data output to SWJ-320S may drop. That can cause the head unit to stop temporarily at the right or left end during printing.

● **Removing USB memory**

If a USB memory module is inserted in the personal computer to which a SWJ-320S machine is connected, click "Stop" in the "Safely Remove Hardware" window by following the instructions given there first and then remove the module.

Leaving a USB memory module inserted can cause [ERROR 201 COMMAND ERROR]. Copy the data onto the hard disk before outputting it for printing.

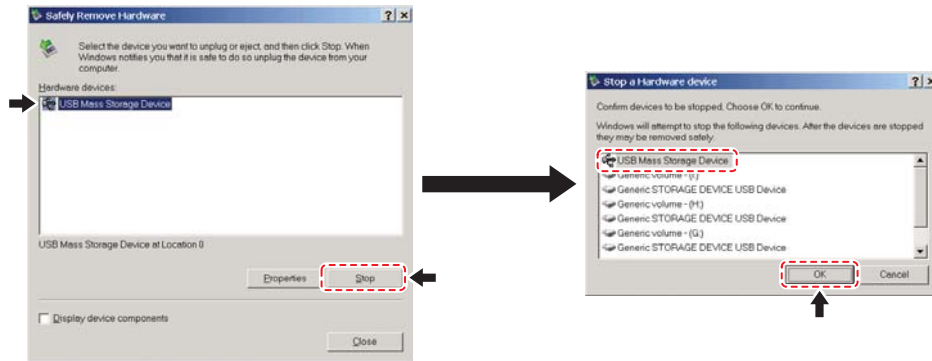

Connecting the power cable

1 Insert the power cable into an inlet of the machine.

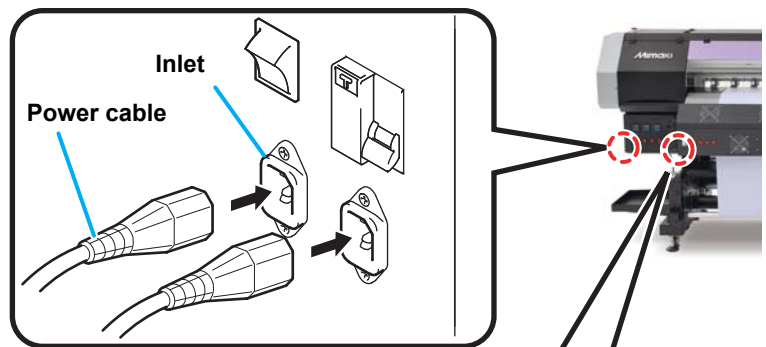

2 Insert the power cable of the Drying fan into the inlet of the Drying fan.

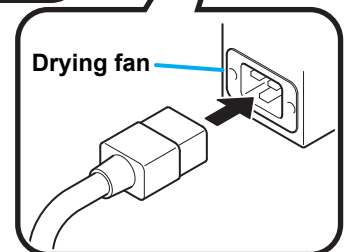

3 Insert the power plug into a plug socket.

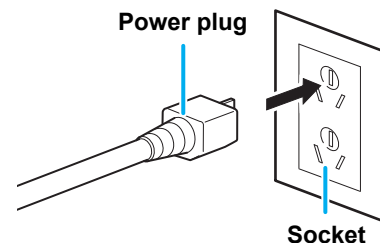

• Do not use any power cables other than the attached power cable.



• Be sure to connect the power cable to the outlet near this machine, and make sure that the power cable can be easily removed.
 • Connect the power cable to the grounded outlet. Otherwise, it may result in fire or an electric shock.

Ink bottle replacement and charging

This unit manages the use-by date and the amount of ink remaining by reading the information of ink IC chip attached on the ink bottle.

Replace the ink bottle, according to the following procedures.

1

Replace the inkbottle.

- (1) Remove the bottle cap.
- (2) Insert the ink pipe near the center of the inside pig.

Important!

- Be sure to check the type and color of ink to be set before replacement.
- If its insertion is not enough, it becomes impossible for ink to use up to the last.
- In such a case, widen the insertion of inner cap until the pipe can move downward with its own weight. If the pipe moves upward, you cannot use ink up to the last.

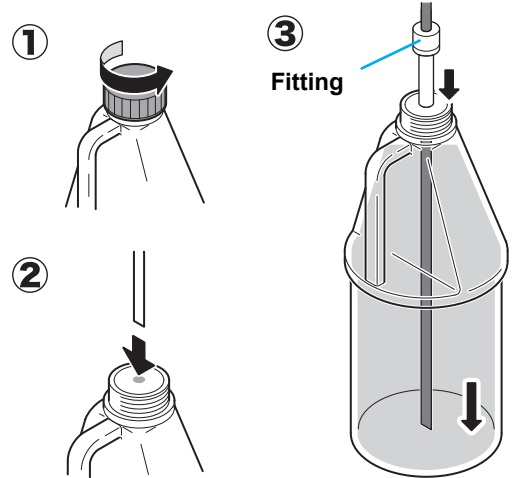

2

Insert the ink IC chip into the ink IC slot.

- Use the IC chip attached on the ink bottle.
- Insert the ink IC chip facing the contacts of IC chip up.

Important!

- Do not dirty or damage the contact of ink IC chip. It may cause not to read the stored information correctly.

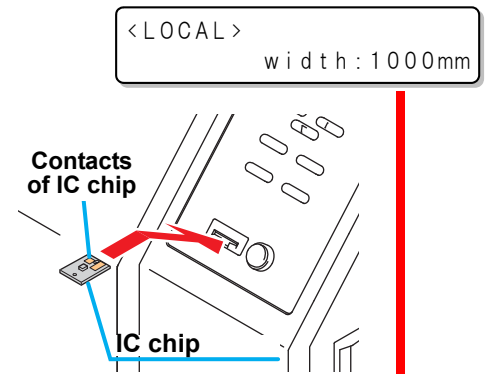

3

Confirm the information of ink IC chip, and press **ENTER** key.

- Confirm the color, ink type, capacity displayed on the display. If incorrect, press **END** key and reenter.
- When an error message such " WRONG INK IC " is displayed, remove the IC chip once and reinsert it.

Important!

- The ink IC chip charged once cannot be undone. Be sure to press **ENTER** key after the displayed information is confirmed.

IC chip information

```
COL:K  CS100:2000cc  
CHARGE START [ENT]
```

(In charging)

```
** CHARGING **  
DON'T REMOVE INK IC
```

Charging completion

```
COMPLETE INK CHARGE  
COL:K  CS100:2000cc
```

4

Confirm the charge completion display.

- When the ink charging is normally completed, the new ink remaining amount is displayed.
- Reinsert the IC chip when an error occurs.

Important!

- Do not remove the ink IC chip during charging. It may cause a trouble of unit or ink IC chip.

1

Before Use

As for the ink IC chip

One ink IC chip is enclosed by one ink bottle.
Marking is applied to the contact side so that each ink color can be recognized.

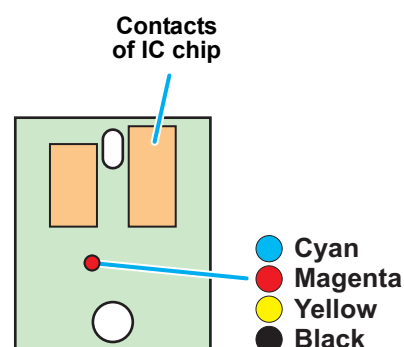

About ink expiration date

The ink bottle has its expiration date.
You can use the bottle in two months after the expiration date indicated on it, however, you cannot use it when three months have passed from the expiration date.

Ex.) When the expiration date is April 2012

May: Usable

June: Usable

July: Unusable

About ink end and ink near end

When the ink remaining amount becomes less, "Ink near end" occurs. Ink replacement is recommended early.
When no more ink is available, the printing is interrupted. Replace the ink bottle with a new one.

Caution in handling of ink bottles



- If you get ink in your eyes, immediately wash your eyes with a lot of clean running water for at least 15 minutes. In doing so, also wash the eyes to rinse ink away completely. Then, consult a doctor as soon as possible.
 - Use genuine ink bottles for this machine. In case of troubles caused by modified ink bottles or the like, it shall be out of the warranty even within the warranty period.
 - If the ink bottle is moved from a cold place to a warm place, leave it in the room temperature for three hours or more before using it.
 - Make sure to store ink bottles in a cool and dark place.
 - Store ink bottles and waste ink tank in a place that is out of the reach of children.
 - Request an industrial waste processor for processing of empty ink bottles.
- Do not shake ink bottles violently. This may result in ink leakage from the ink bottles.
 - Never refill the ink bottles with ink. This may result in troubles.
MIMAKI will not bear any responsibility for any damage caused by the use of the ink bottles refilled with ink.
 - Do not touch or stain the contacts of the Ink IC chip. This may cause damages on printed circuit boards.

Usable media sizes and notes for handling are described.

Usable sizes of media

Model		SWJ-320S
Type of Recommended media		Tarpaulin/ FF (Flexible Face)/ PVC
Maximum width		3250 mm
Minimum width		210 mm
Maximum printing width		3200 mm
Roll media	Thickness	1.0 mm or less
	Roll outside diameter	Feeding device Maximum: Φ 220 mm
		Take-up device Maximum: Φ 120 mm
	Roll weight	Feeding device Maximum: 100 kg
		Take-up device Maximum: 40 kg
	Roll inside diameter	3 inch
	Side printed	Roll inside/out side Both possible
Roll end treatment	The roll end is gently fixed to the core with weak-adhesive tape or weak glue for easy removal.	

1

Before Use

Caution in handling of medias

Pay attention to the followings for handling of medias.

Important!

- **Wear gloves when handling the media.**
Take care not to touch the media with bare hands since the media may be dirtied by the fingerprints or fat of hands.
- **Do not leave the heater ON a long time in the condition that the media is set.**
The media becomes wavy, and this causes the media jamming.
- **Use media recommended by MIMAKI to ensure reliable, high-quality printing.**
Set the heater temperature to meet the characteristics of the media.
- **Set the temperature of the Pre-heater, Print heater and Post-heater according to the type and characteristics of the media used.**
Set the temperature of pre-heater and print heater according to the type and characteristics of media.
- **Pay attention to the expansion and contraction of the media.**
Do not use media immediately after unpacking. The media can be affected by the room temperature and humidity, and thus it may expand and contract.
The media have to be left in the atmosphere in which they are to be used for 30 minutes or more after unpacked.
- **Do not use curled media.**
This may result in paper jamming.
If a regular-sized coated sheet of media is rolled and stored, the coated side has to face outside.
- **Be careful to dusts on the edge face of the medium.**
Some rolls have dusts contained in the package gathered on the edge surface of the roll. If you use as it is, the drawing quality may be degraded due to nozzle missing or ink drops. Be sure to set the roll after removing dusts adhering on the edge face of the roll.

Print Head

This machine is equipped with the print head to discharge ink.
This chapter explains about the print head and its handling.

Number of mounted print heads

SWJ-320S2	SWJ-320S4
2 head	4 head

About print head

The print head is a part to complete your picture by discharging ink on the specified position.
As this is a very delicate part, fully be careful about its handling when using.

Important!

- In the print head used in this machine, up to 16 nozzles with discharge defect (nozzle missing or deflection) per nozzle line may be included by default.
In the print mode where the nozzle recovery function is valid, as the nozzle with discharge defect can be recovered by other nozzle for printing, it does not receive influence of defect nozzle.
In the print mode where the nozzle recovery function is invalid, as the nozzle with discharge defect cannot be recovered, printed result may have nozzle missing.
If printed quality receives influence, perform printing in the mode where the nozzle recovery function is valid. "Valid/ invalid of nozzle recovery function in each print mode" (☞ P.4-18)

Note for handling print head

About handling of the print head, be careful about the items below:

Important!

- Do not touch the nozzle surface of the print head other than for wipe at performing ink purge (☞ P.4-14).
- Carefully read the explanation of ink purge (☞ P.4-14) before wipe at performing ink purge.

To keep print head status

To perform stable printing, be careful about the items below in order to keep the print head status:

Important!

- Be sure to perform maintenance for the ink cap and the wiper of capping station every day.
If you leave it dirty, dirt may adhere to the nozzle surface, or, dust and dry ink may be rubbed against the nozzle. It may cause discharge defect.
- Dust and very thin fibers of the media adhere to the platen and the media holder.
If they adhere to the carriage bottom surface or the nozzle surface, it may stain the media and discharge defect may occur.
Clean the platen and the media holder every day.
- When the carriage bottom surface became stained due to ink and thin fibers of the media, immediately clean it.
If you leave it dirty, dust and dry ink may be rubbed against the nozzle at wiping operation when performing head cleaning.
- When you clean the carriage bottom surface, fully be careful not to rub the nozzle surface.

Chapter 2

Basic Operations



This chapter

describes procedures and setting methods for ink and media preparation, and printing.

Workflow	2-2	Test Printing	2-23
Turning the Power ON/OFF	2-3	Test Printing	2-24
Turning the Power ON	2-3	Head Cleaning	2-25
Turning the Power OFF	2-4	About head cleaning	2-25
Setting a Media	2-5	Perform head cleaning depending	
Note for media setting	2-5	on the test printing result	2-25
Setting a roll media	2-5	Set the media feeding	2-26
Setting a narrow roll media	2-10	Setting Feed Correction	2-26
Adjusting the Head Height	2-14	Checking the media feeding amount	
Setting the printing area	2-17	deviation during printing	2-28
Setting leaf media	2-18	Setting Feed Check Pattern	2-28
Changing the printing origin	2-19	Aligning the Print Result Lengths	2-30
Preparing for the Heaters	2-20	Setting Feed Check Pattern	2-30
Setting the heater	2-20	Correct the ink drop position for	
Setting the adsorption fan	2-21	bidirectional printing	2-32
Setting the drying fan	2-22	Printing Data	2-34
If ruck is generated on the printing surface		Starting a Printing Operation	2-34
of the media	2-22	Stopping a printing operation halfway	2-35
		Deleting Received Data (Data Clear)	2-35
		Using method of weight for assistant roller	2-36

Workflow

1 Turning the Power ON/OFF

Referring to “Turning the Power ON/OFF” (☞ P.2-3).

2 Setting a Media

Referring to “Setting a Media” (☞ P.2-5).

3 Preparing for the Heaters

Referring to “Preparing for the Heaters” (☞ P.2-20).

4 Test Printing

Referring to “Test Printing” (☞ P.2-23).

5 Set the media feeding

Referring to “Set the media feeding” (☞ P.2-26).

6 Correct the ink drop position for bidirectional printing

Referring to “Correct the ink drop position for bidirectional printing” (☞ P.2-32).

7 Printing Data

Referring to “Printing Data” (☞ P.2-34).

Turning the Power ON/OFF

Turning the Power ON

This machine is provided with the following two power switches:

Main power switch: Two switches are located on the side of this machine. Keep this switch ON all the time.

Power switch : Normally, use this switch to turn the power ON/OFF.

The power switch lights when the power is ON.

1 Turn the main power switch ON.

- Set the two main power switches located on the side of this machine to the "I" side.

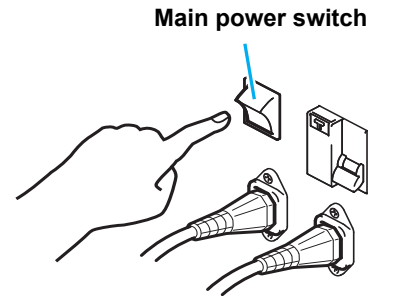

2 Turn the power switch ON.

- Push the power switch located on the operation panel.

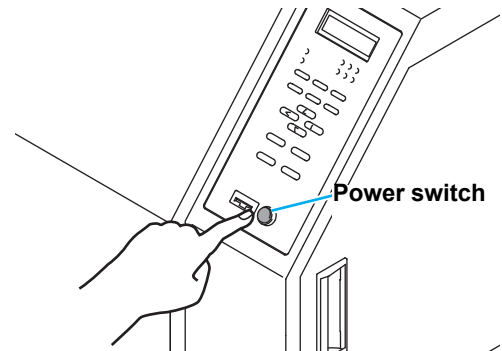

- The firmware version is displayed when the power is turned ON.
- The machine performs its initial operation.

JV400-160 Start-up
Ver 1.00R0

3 The machine enters LOCAL.

<LOCAL>

4 Turn ON the power of the connected PC.

Important!

- Turn the power ON after the front cover and maintenance cover are closed.
- The head nozzle may result in nozzle clogging if the main power switch is left OFF for a long time.

Turning the Power OFF

When having ended the operation of the machine, turn the power OFF by pressing the power switch located on the front side.

Check the following items when turning the power OFF.

- If the machine is receiving data from the PC or if there is any data that has not been output yet
- If the head has returned to the capping station
- If any error has occurred (☞ P.5-8 “Error messages”)

1 Turn OFF the power of the connected PC.

2 Press the power switch to turn the power OFF.

- The power switch blinks.
- Do not turn OFF the main power switch located on the side of the machine.
- To use this machine again, light the lamp by pressing the power switch.

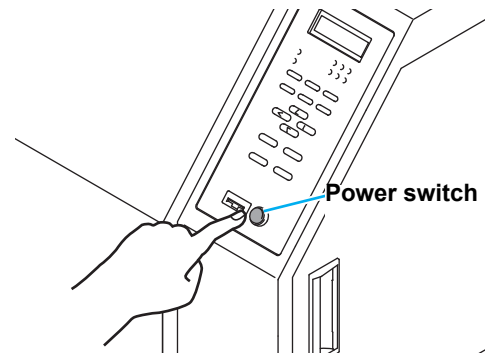

Cautions about Turning the Power OFF

● Do not turn the main power switch OFF.

When the main power switch is ON, the power periodically turns ON and the nozzle clogging prevention function (flushing function) and the pressure adjusting function operate.

When the main power switch has been turned OFF, the auto maintenance functions, such as flushing, do not operate, and this may cause nozzle clogging.

If the cover is opened, the auto maintenance function such as the flushing function does not work.

● Turn the power OFF after having checked the position of the head.

If the power is turned OFF in a state where the head has not returned to the capping station, the ink head dries, which may cause nozzle clogging.

In this case, turn the power ON again and check that the head has returned to the capping station, and then turn the power OFF.

● Do not turn the power OFF during printing.

The head may not return to the capping station.

● After having turned the power switch OFF, turn the main power switch OFF.

When turning the main power switch off for moving the machine or for solving the error or the like, press the power switch on the front of the machine, check the display is turned off on the operation panel, and then turn the main power switch off.

● Be sure to turn off the main power of heater unit and drying fan.

Setting a Media

This machine can be used with a roll media and leaf media.
For usable medias, refer to P.1-13 "Usable sizes of media".

Note for media setting

When setting media, read the following notes carefully.



- Take care not to drop the media on a foot or so when the media is set. It may cause an injury due to the media.
- Set a media after turning OFF the Drying fan and the Blowing fan.
- Be sure to set the media with two or more persons.
- When setting the media, fully be careful so that you may not clip your finger etc. between the media and the machine.

Setting a roll media

Here, the setting procedures when the print surface faces outside are explained.



- Narrow roll media may slip on the shaft and feeding cannot be performed properly. For setting a narrow roll media, refer to "Setting a narrow roll media" (🗨️ P.2-10)

1

Put the roll media onto two shafts on the backside of unit.

- Put roll media at the center of the shaft.

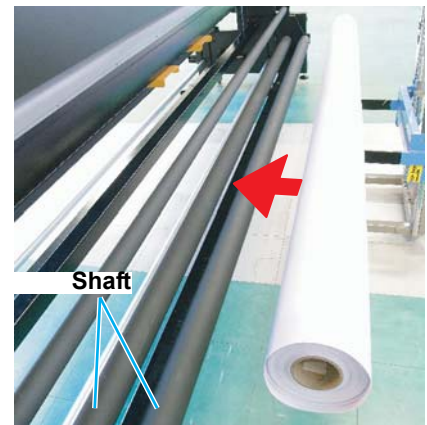

2

Set the roll guide for right and left.

- (1) Move the roll guide to the position of 1mm away from the media (paper core).

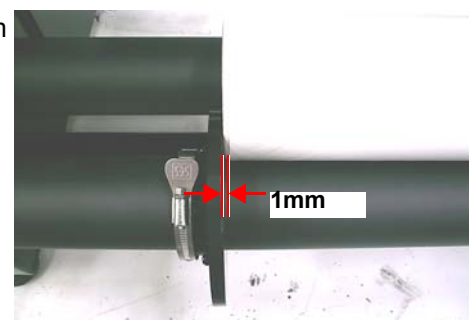
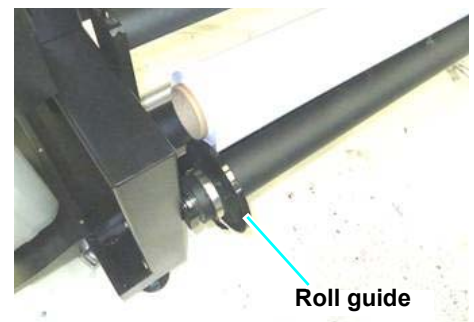

2

Basic Operations

(2) Rotate the knob and fix the roll guide.

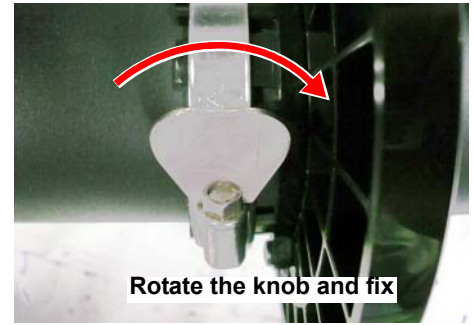

(3) Check that the roll guide is attached vertically against the feeding roll shaft.

(4) Feed the media and check that the roll guide does not apply any stress on the media/ the paper core.

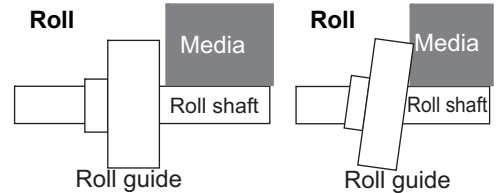

Important!

- If you perform printing with the status that the roll guide applies stress on the media/ the paper core, it is possible to detect media end by mistake.

3

Pass the media through under the tension bar and feed the media a little longer.

- Pull the media out of the roll so that the media can be grasped from the front of the machine.



Route for the paper of its print-side inside.

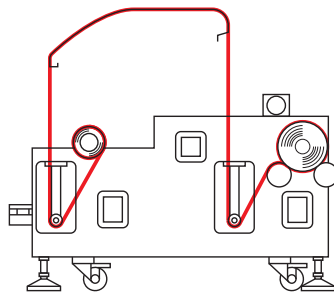

Route for the paper of its print-side outside.

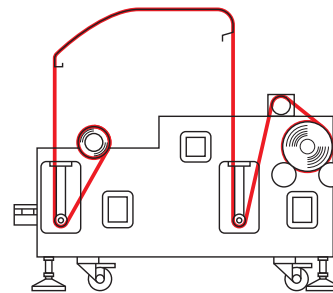

4

Open the front cover and move the media press to outside.

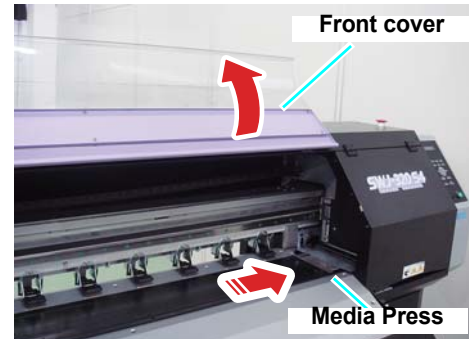
**5**

Slide the media from the back to the front.

- (1) Make the Feeding direction switch "OFF".
- (2) Pull the media until the tension bar moves upward completely (to the highest position).
- (3) Return the media with the tension bar's weight. (If it cannot return with its weight, move the tension bar downward with your hand.)



- Insert the roll media between the platen and the pinch roller, and slide it to the front.
- Pull the media out to the front of this machine with enough length.

**6**

Lower the clamp lever to hold the media.

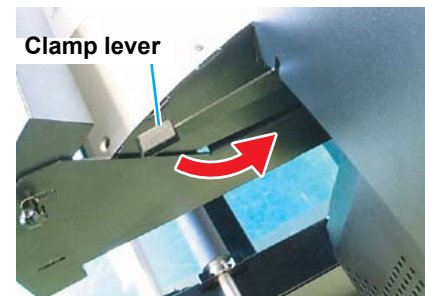

7

On the backside of unit, set the feeding device.

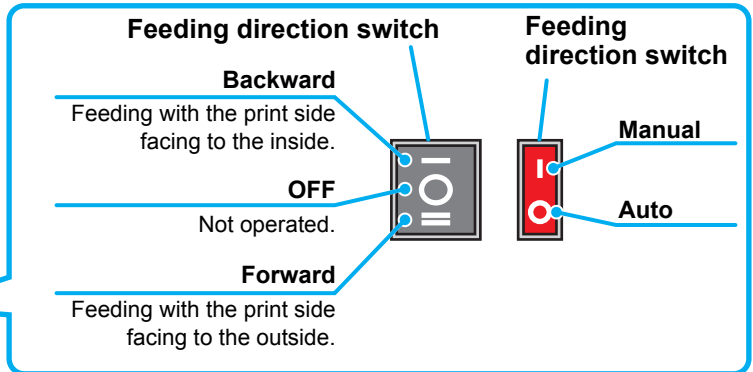
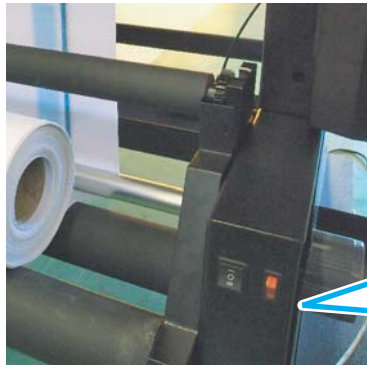

If the print-side is inside of roll,

- (1) Set the Feeding direction switch at the “Backward” position (upward).
- (2) Set the Feeding manual switch at the “Auto” position (downward).



- If the print-side is outside of roll,
Set the Feeding direction switch at the “Forward” position (downward).
- Set the Feeding manual switch at the “Manual” position (upward).

Print-side is inside:

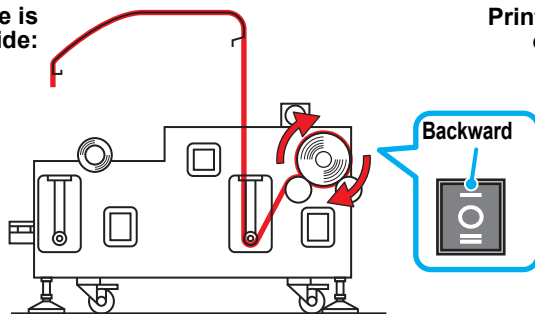

Print-side is outside:

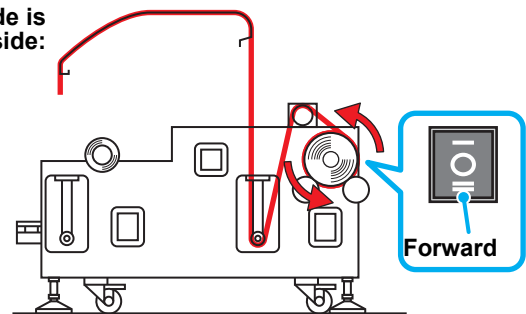

8

Prepare for the take-up device.

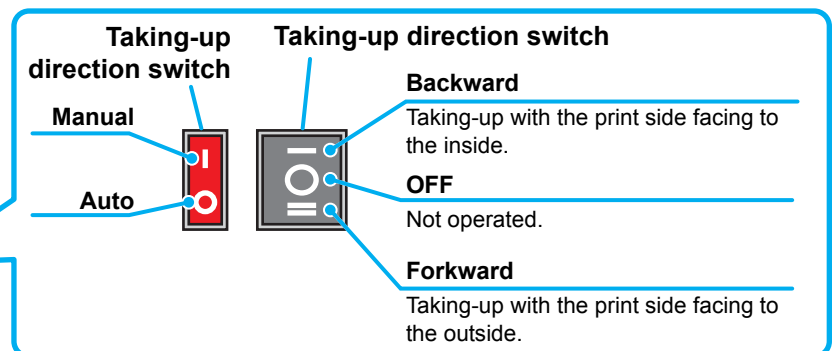
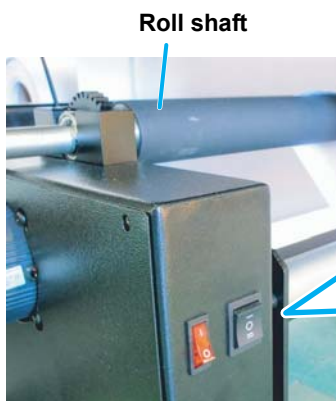

- (1) Set the taking-up direction switch to “OFF” (Center)
- (2) Set the taking-up manual switch to “Auto” (Lower)

9 Feed the media to the tension bar.

- (1) Pressing the  key, feed the media until the tension bar at the rolling side is being hidden.
 - Check the media end is not caught into the slot on the post-heater, and then feed the media.

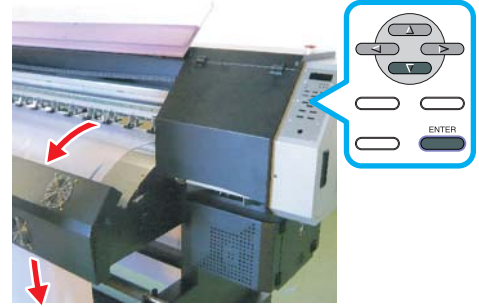



10 Fix the media to the roll shaft.

- (1) Lift the tension bar by hand to the full top position.
- (2) Put the media under the tension bar and fix the media at the center of the roll shaft with an adhesive tape.
- (3) In the same manner, fix the left side and right side of the media.
 - Pull roll media evenly for right and left, check that there is no slack or waviness on the media, and paste tape in numerical order.
 - When you place the tape, consider the rolling-up direction.

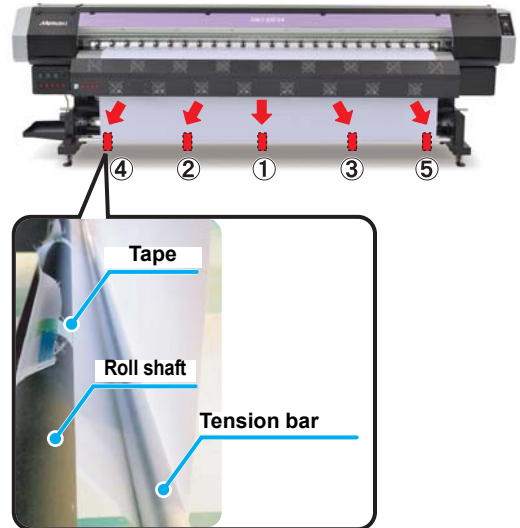
Important! • If you raise the tension bar while holding the center of it, the bar may bend. When raising the tension bar, be sure to hold the bar edge.



11 Roll up the media.

- (1) Set the taking-up direction switch to "Forward"/"Backward" according to the taking-up method.
- (2) Press , and rotate the roll shaft 2-3 times to take up the media.
- (3) Press the  key.



- Setting the Feeding manual switch at the "Manual" position and turning ON either of the upper or the lower sides of the Feeding direction switch, rolling up will start. When stopping, set the Feeding direction switch at the neutral position (OFF), or turn the Feeding manual switch at the "AUTO" position.

Roll up with the print-side outside.

Roll up with the print-side inside.

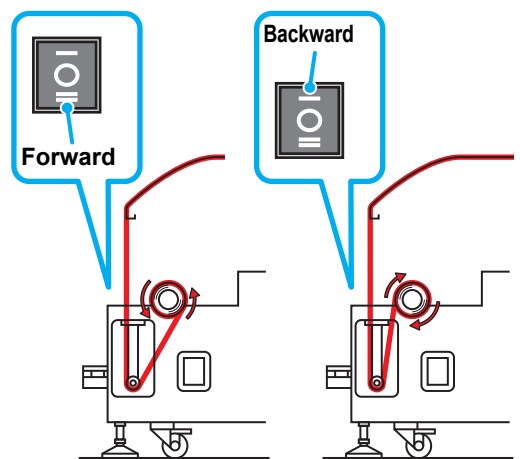

12 Hold the media with the media press gently.

- Set the media so that no media sticks out from the right end pinch roller to the right side.
- Set the media press to the position of 3mm away from the media.
- When using a thick media, remove the media press from the media before printing.

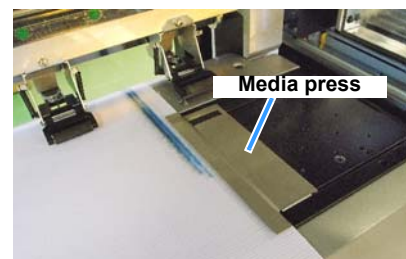

13 Close the front cover.

Setting a narrow roll media

Important!

- Use the narrow roll media holder only for the media of 25kg and less.

1

Remove the screw and feeding gear cover.



2

Take off the narrow roll shaft from the feeding device.

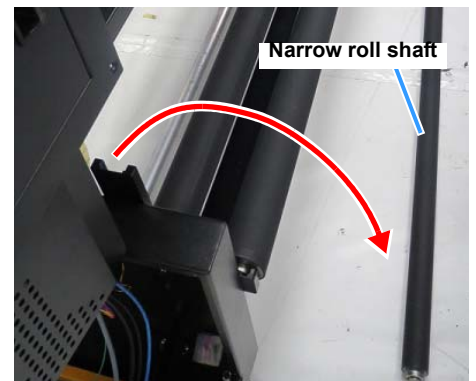

3

Set the narrow roll media to the narrow shaft and place the media in the center of the shaft.

- Fix the media with the attached roll holder.
- Attach the feeding gear cover.



4

Pass the media through under the tension bar and feed the media a little longer.

- Pull the media out of the roll so that the media can be grasped from the front of the machine.

Route for the paper of its print-side outside.

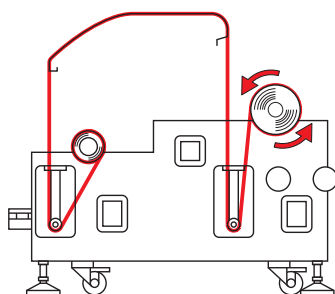

Route for the paper of its print-side inside.

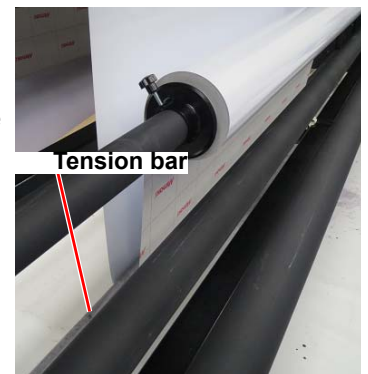
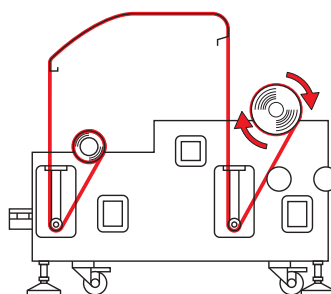

5

Open the front cover and move the media press to outside.

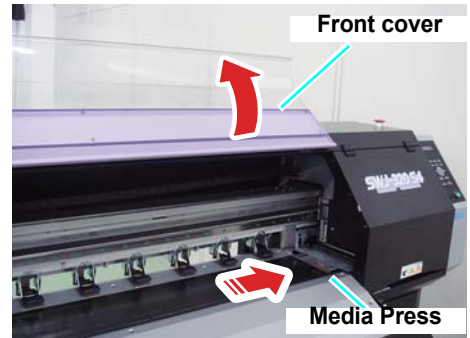
**6**

Slide the media from the back to the front.

- (1) Make the Feeding direction switch "OFF".
- (2) Pull the media until the tension bar moves upward completely (to the highest position).
- (3) Return the media with the tension bar's weight. (If it cannot return with its weight, move the tension bar downward with your hand.)



- Insert the roll media between the platen and the pinch roller, and slide it to the front.
- Pull the media out to the front of this machine with enough length.

**7**

Lower the clamp lever to hold the media.

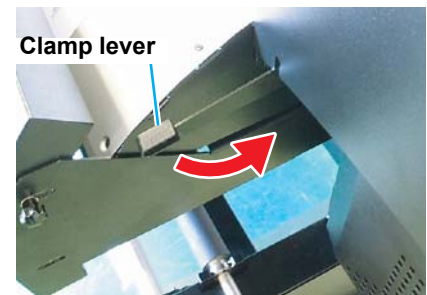

2

8

On the backside of unit, set the feeding device.

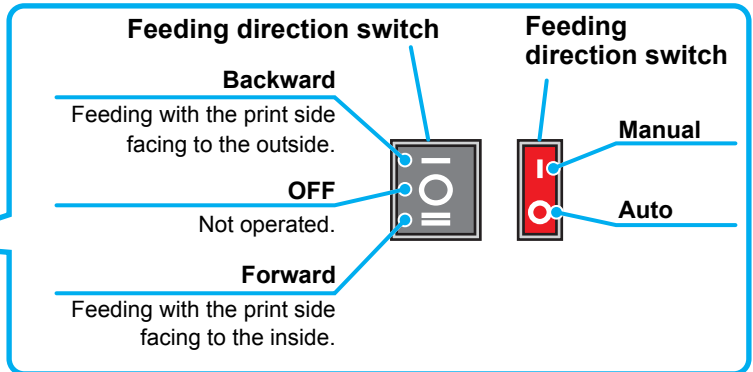
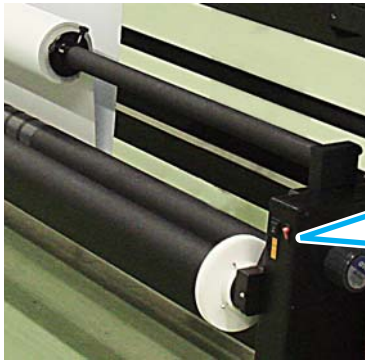

If the print-side is outside of roll,

- (1) Set the Feeding direction switch at the "Backward" position (upward).
- (2) Set the Feeding manual switch at the "Auto" position (downward).



- If the print-side is inside of roll,
Set the Feeding direction switch at the "Forward" position (downward).
- Set the Feeding manual switch at the "Manual" position (upward).

Print-side is outside:

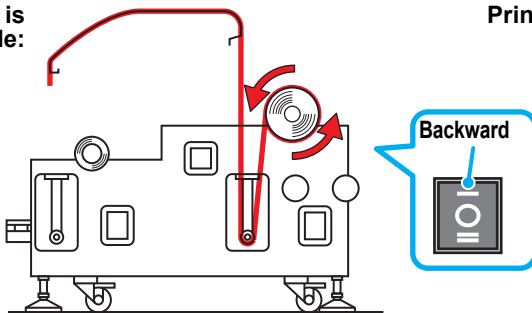

Print-side is inside:

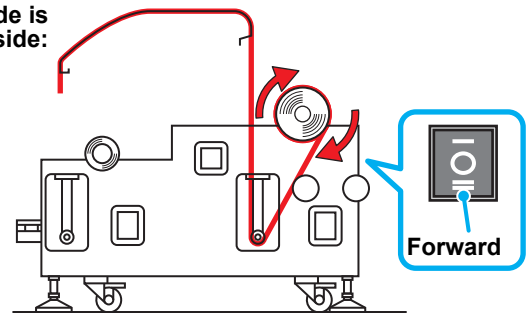

9

Prepare for the take-up device.

Roll shaft

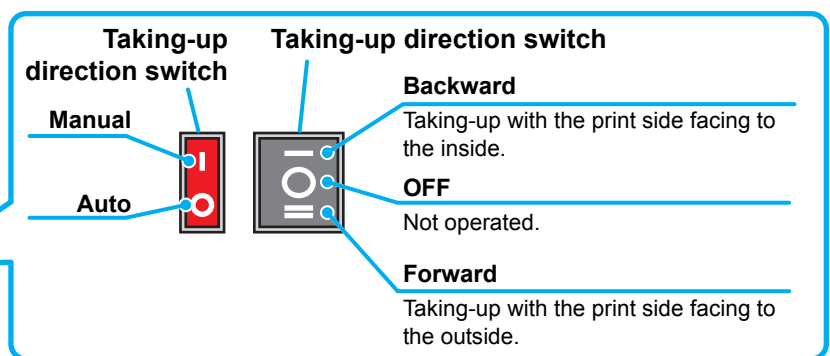
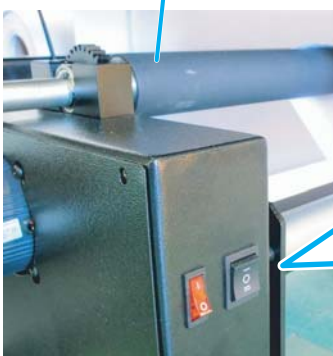

- (1) Set the taking-up direction switch to "OFF" (Center)
- (2) Set the taking-up manual switch to "Auto" (Lower)

10 Feed the media to the tension bar.

- Pressing the  key, feed the media until the tension bar at the rolling side is being hidden.
 - Check the media end is not caught into the slot on the post-heater, and then feed the media.

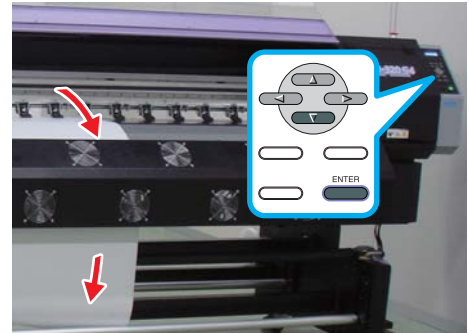

11 Fix the media to the roll shaft.



- Lift the tension bar by hand to the full top position.
- Put the media under the tension bar and fix the media at the center of the roll shaft with an adhesive tape.
 - In the same manner, fix the left side and right side of the media.
 - Pull roll media evenly for right and left, check that there is no slack or waviness on the media, and paste tape in numerical order.
 - When you place the tape, consider the rolling-up direction.

Important!

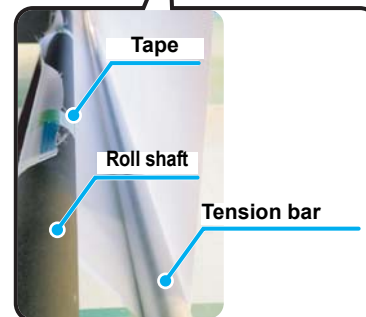
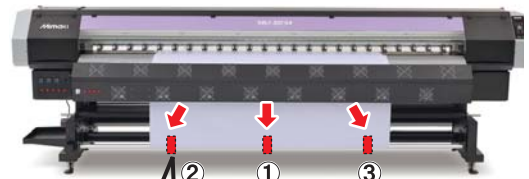
- If you raise the tension bar while holding the center of it, the bar may bend. When raising the tension bar, be sure to hold the bar edge.



12 Roll up the media.

- Set the taking-up direction switch to "Forward"/"Backward" according to the taking-up method.
- Press , and rotate the roll shaft 2-3 times to take up the media.
- Press the  key.



- Setting the Feeding manual switch at the "Manual" position and turning ON either of the upper or the lower sides of the Feeding direction switch, rolling up will start. When stopping, set the Feeding direction switch at the neutral position (OFF), or turn the Feeding manual switch at the "AUTO" position.

Roll up with the print-side outside.

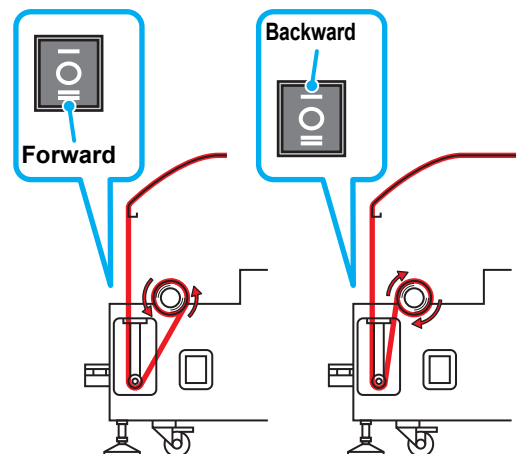

13 Hold the media with the media press gently.

- Set the media so that no media sticks out from the right end pinch roller to the right side.
- Set the media press to the position of 3mm away from the media.
- When using a thick media, remove the media press from the media before printing.

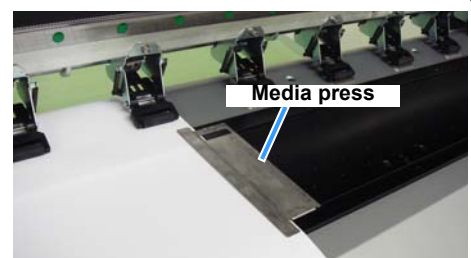

14 Close the front cover.

Adjusting the Head Height

Important!

- Unless the head is properly set at the height against the thickness of the media you use, deterioration of the printing quality or the breakage of the head could be caused. Perform the head height adjustment each time when you change the media.
- When the height of the head is set at 2.0mm (minimum value) from the surface of the platen, pay attention to the following points:
 - (1) Use the media with surface without wrinkles and convex-concave shapes. The media and the head may graze with each other, or the media may be caught and pressed by the head causing a jam or being clogged at some point.
- After adjusting the head height, make sure to perform the correction of the dot position. (☞ P.2-32)
- If the printing area has been set, the printing area is reset.
Set the printing area again.

1

Set the media and push down the clamp lever.

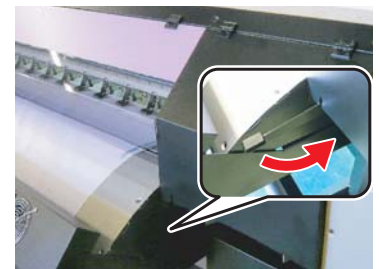

2

Set the adsorption fan to ON.

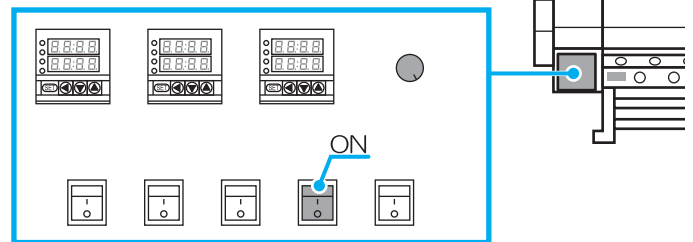

3

Press the **MEDIA SET** key.

```
MEDIA SET
MEDIA RESET [ENT]
```

4

Press **▲ ▼** to select **[Head Height]**.

```
MEDIA SET
HEAD HEIGHT [ENT]
```

5

Press the **ENTER** key twice.

- The carriage will move.

6

Press the **ENTER** key.

- (1) Open the front cover and the maintenance cover R.
- (2) Move the carriage by hand until the head height adjusting rod comes on the media.
 - If the carriage hits the spacer or the Media press, go to the step 9 and raise the head.

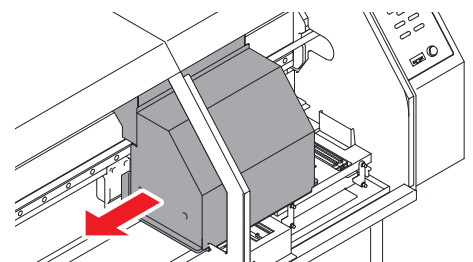

7

Adjust the head height.

(1) Insert the head height adjusting block between the media and the head.



- Turn up the surface with the number to which you want to adjust and insert it between the media and the head.

If you adjust it to 2.0mm, turn up the surface with "2.0" and insert the side with "2.0".

If you adjust it to 2.5mm, turn up the surface with "2.5" and insert it.

If you adjust it to 3.0mm, turn up the surface with "3.0" and insert the side with "3.0"

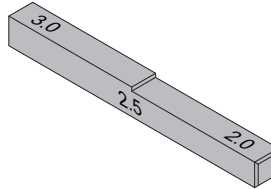

(2) Until the head bottom surface touches the head height adjusting block, rotate the height adjusting screw.

Clockwise: Head rising

Counter-clockwise: Head lowering

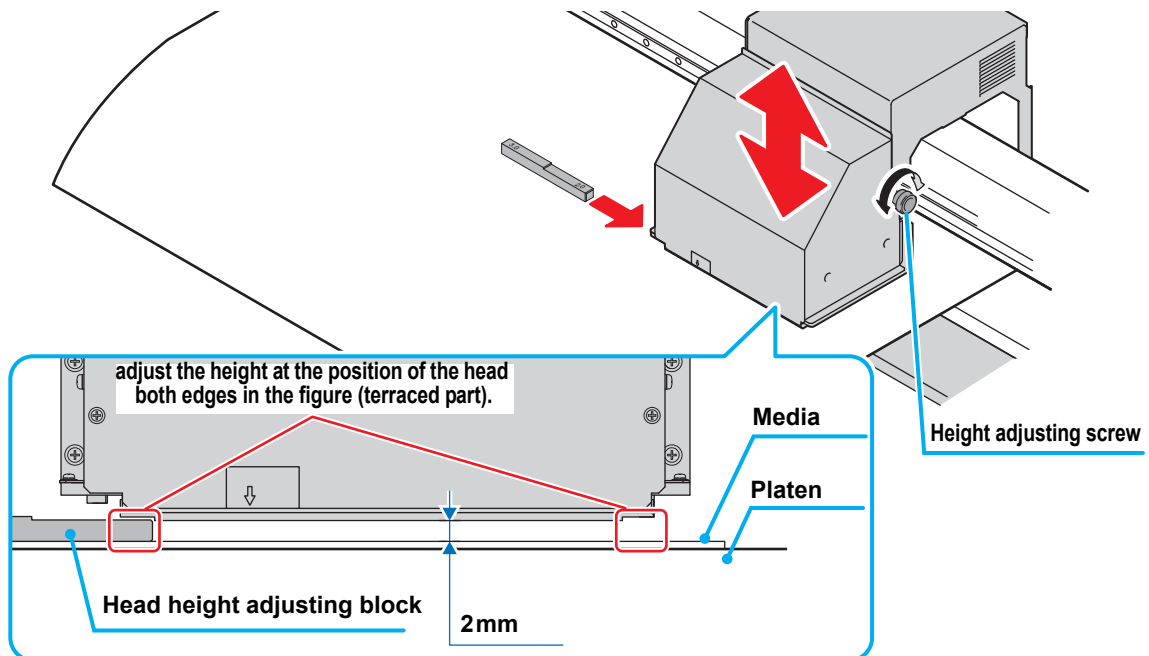

8

Close the cover and press the **ENTER** key.

HEAD HEIGHT
PLEASE WAIT

Important!

- Recommended printhead gap for printing is around 2mm. If the gap between the head and the media is larger, the blurring of printed images, the changing in color during the printing or the nozzle missing due to ink mist may occur.
- If concavity and convexity occur due to waviness on the media surface etc., raise the head in order of 2.5mm, 3mm until it does not touch the media. However, if you raise the head, the image quality may be degraded.
- After adjusting the height, perform "Correct the ink drop position for bidirectional printing (☞ P.2-32)".

Entering the media remaining amount

When [MEDIA RESIDUAL] of the maintenance function is "ON" (☞ P.3-14), the screen for entering media remaining amount is displayed after detecting the media width.

1

Display the screen for entering media remaining amount.

Input of MediaLength
MEDIA LENGHT =xxx.xm

2

Press  and  key to enter the media remaining amount.

Input of MediaLength
MEDIA LENGHT = 50.0m

3

Press the  key.

Setting the printing area

When [MEDIA RESIDUAL] of the maintenance function is "ON" (P.3-14), the screen for entering media remaining amount is displayed after detecting the media width.

1 Press on the media selection screen, and select ROLL/LEAF.

MEDIA SET
ROLL < > LEAF



- When detecting roll media, the rear edge is detected during printing, and when there become no media, "NO MEDIA" is displayed.
- When detecting leaf media, the rear edge is not detected.
- When detecting roll media, be sure to use the tension bar.

Important! • When detecting roll media, you cannot move the media with the  key.



2 Input width of the printing area.

- Set the printing area in the Y direction.



If you know the printing width:

- (1) Press   to input the value.
- (2) Press the  key.
 - The carriage moves.

PRINT AREA [WIDTH]
: 186  mm



Important! • When inputting the printing width with  , be careful that it may print out of the media depending on the print start position set on the Step 3.

If you do not know the printing width:

- (1) Press the   key to select "MANUAL".
- (2) Press the  key.
 - The carriage moves.



PRINT AREA [WIDTH]
:  MANUAL mm

3 Set the printing origin.

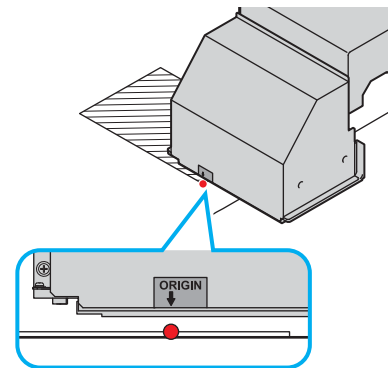



- (1) Press   to move the carriage to the print start position (origin).
 - Put an arrow mark of the carriage on the setting position.
- (2) Press the  key.
 - If "MANUAL" is set on the Step 2, go to the Step 4.
 - If a number is entered for the printing width on the Step 2, the left end of the printing area is automatically adjusted to the entered number, and the mode is returned to the LOCAL. Skip the step 4.

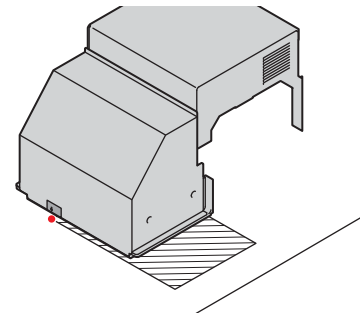

4 Set the width of the printing area.

- (1) Press   to move the carriage to the left end of the printing area.
 - Put an arrow mark of the carriage on the setting position.
- (2) Press the  key.
 - After capping, the screen returns to LOCAL.



- If you set the wrong printing area, detect again from the Step 1 after performing the operation below.
 - (1) Press the  key.
 - (2) Press   to select [MEDIA RESET].
 - (3) Press the  key.
 - (4) Press the  key.

Setting leaf media

Unlike roll media, leaf media does not need to be retained with the roll holders.

1 Open the front cover.

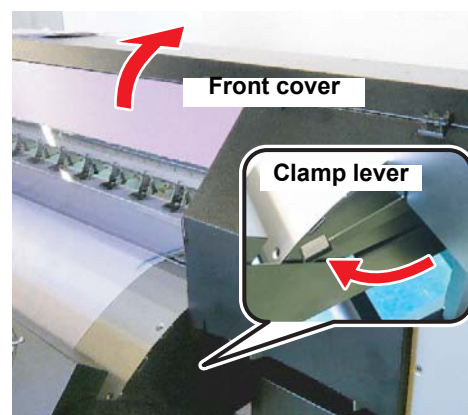

2 Raise the clamp lever.

3 Insert the leaf media between the platen and the pinch rollers.

- Set the media so that no media sticks out from the right end pinch roller to the right side.
- Set the media so that the media end does not reach the slot of the post-heater.

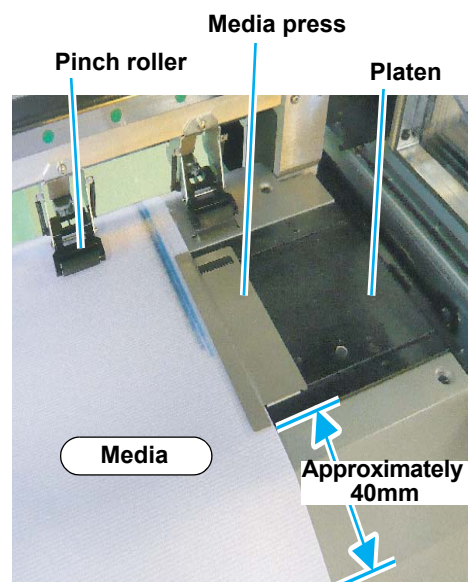

4 Hold the media with the media press gently.

- Set the media so that no media sticks out from the right end pinch roller to the right side.
- When using a thick media, remove the media press from the media before printing.

5 Push down the clamp lever.

- Set the media straight.



- Set the media on the black part of the platen so that it comes out approximately 40mm.

6 Close the front cover and Press the **ENTER** key.

7 Press the **▶** key to select "LEAF" .

MEDIA SELECT
ROLL < > LEAF

8 Set the printing area

- Set the printing area according to the same procedures as the roll media.
- It returns to the local mode when the setting is completed.

** MEDIA DETECT **

Changing the printing origin

The position of the printing origin can be changed.
Moving the carriage to the changing position and deciding the position.

1

In Local, Press    .





- It enters into the origin setting mode.

```
ORIGIN SETUP
0.0      - - - -
```

2

Set an arrow mark of the carriage to the changing position by pressing

   .

- Select the carriage and media, moving the point with    .

Important!

- When detecting roll media, you cannot move the media with the  key.

```
ORIGIN  SETUP
0.0      0.0
Origin   Origin
(Length) (Width)
```

3

After determining the origin, press the  key.

- The printing origin is changed.

```
ORIGIN SETUP
** ORIGIN **
```

2

Preparing for the Heaters

Setting the heater

Set the heater temperature.

Set the heater temperature according to the media to use and environment conditions.

- It may take several minutes to tens of minutes for the set temperature to be reached, depending on the ambient temperature.

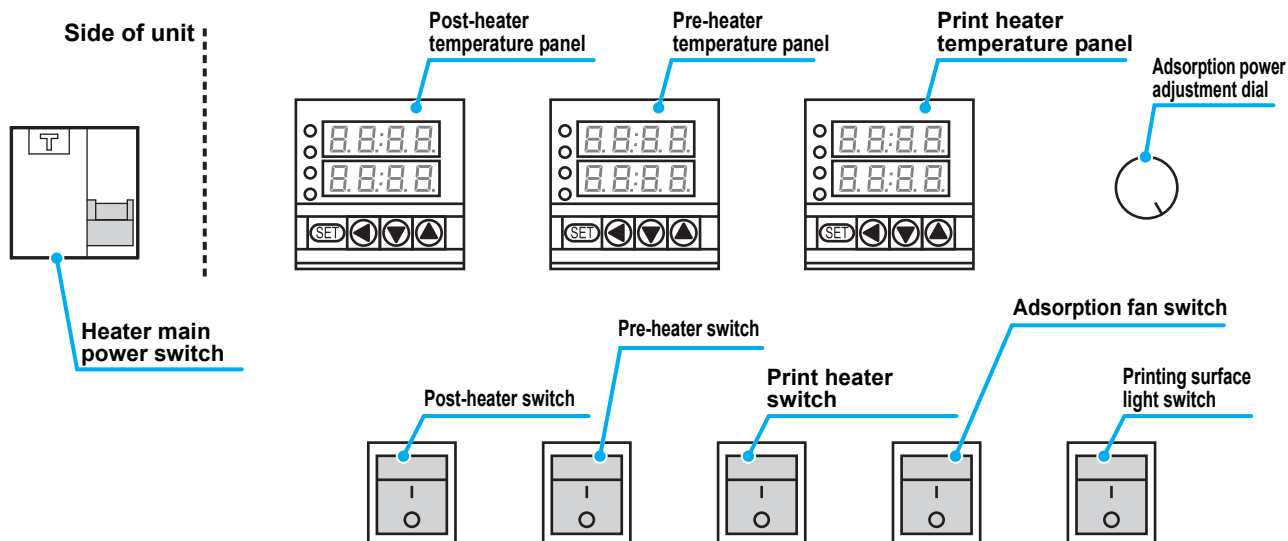

1 Turn on the main power switch of heater unit.

- When turning off the power of heater unit, be sure to turn off the main power switch.

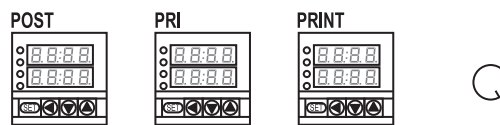

2 Turn on the power of each platen heater.



- When the power is not supplied even by turning on/off the power switch, check that the main power switch of heater on the side of unit is ON.



3 Set the temperature of each heater.

Shift : ◀ ▶
Temperature set : ▼ ▲

- (1) Press **SET** .
•The set temperature is blinking.
- (2) Set the temperature by pressing ◀ and ▼ ▲ .
- (3) Press **SET** again to determine the set temperature.
•The heater starts to get hot.

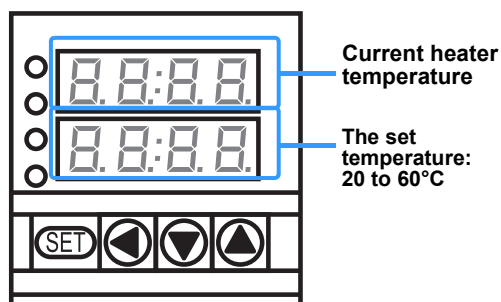

Important!

- Use this machine under 20 to 30°C. The temperature may not reach the set value due to the environmental temperature condition.
- Though you can enter up to 70°C on the heater temperature panel, to use the machine safely, the upper limit of the setting value shall be under 60°C.
- Temperature displayed on heater temperature panel shows temperature inside the heater. If it touches with media, the heater surface temperature will be lower than the displayed one, but this is not abnormal.

Setting the adsorption fan

1 Turn on the power of adsorption fan.

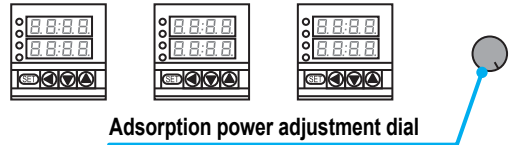

2 Adjust the adsorption power by rotating the adsorption power adjustment dial.

- Clockwise: Stronger
- Counter-clockwise: Weaker



- If the adsorption power is strong: Unevenness feeding may occur.
- If the adsorption power is weak: The media is not fixed and may contact to the head.
- Adjust the adsorption power according to the media to use.
- Adjust at the position between 9 o'clock and 1 o'clock.
- Be sure to execute "FEED COMP." after the adjustment of adsorption power. (☞ P.2-26)

Setting the drying fan

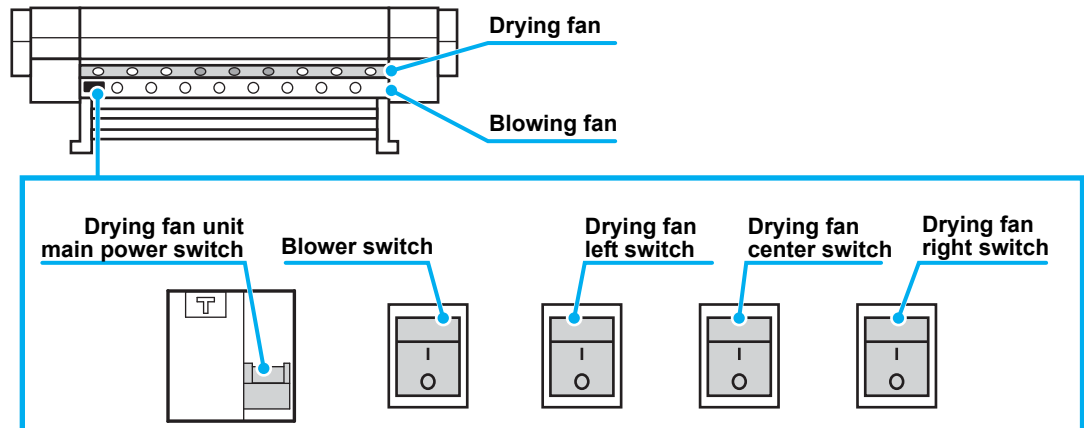

1

Turn on the main power switch of drying fan unit.

- When turning off the power of unit, also, turn off the main power of drying fan.

2

Turning on the blower switch.

3

Turn on the switch of each drying fan according to the position and width of media.

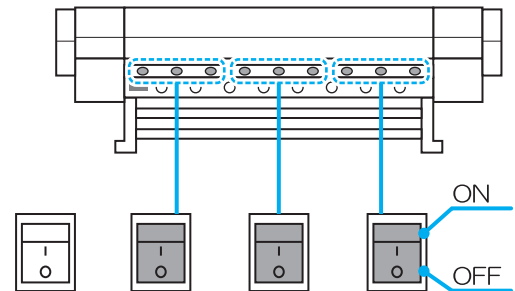

If ruck is generated on the printing surface of the media

When you use the media such as thin FF, tarpaulin, tarpaulin, etc., if ruck is generated on the printing surface of it, ruck may be improved with the temperature setting below:

- Set the temperature of the pre heater higher and that of the print heater lower.

e.g. Pre heater: 60 degrees, Print heater: 30 degrees

- Using the drying fan, lower the post heater temperature. (Or, turn off the heater.)

e.g. Post heater: OFF, Drying fan: ON, Blast fan: ON

Test Printing

Print a test pattern to check that there are no discharging defects such as nozzle clogging (slight touching of ink or nozzle missing).

Relationship between head row and test pattern

Important!

• The relations between head row and test pattern print position are as follow.

● For SWJ-320S2

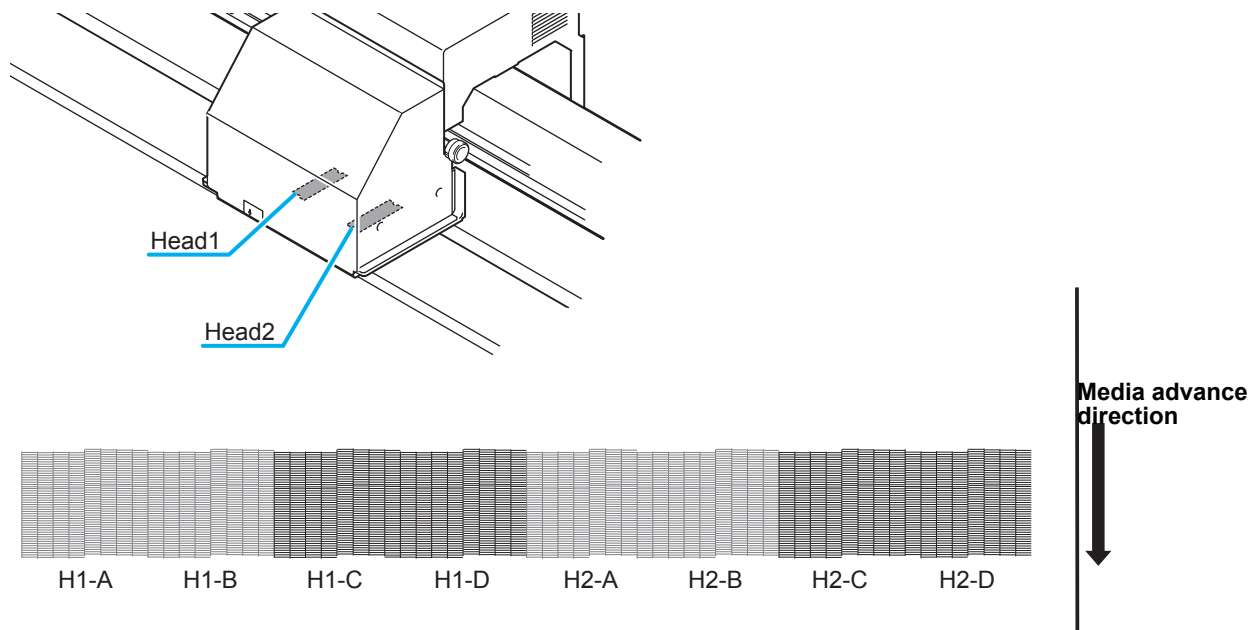

● For SWJ-320S4

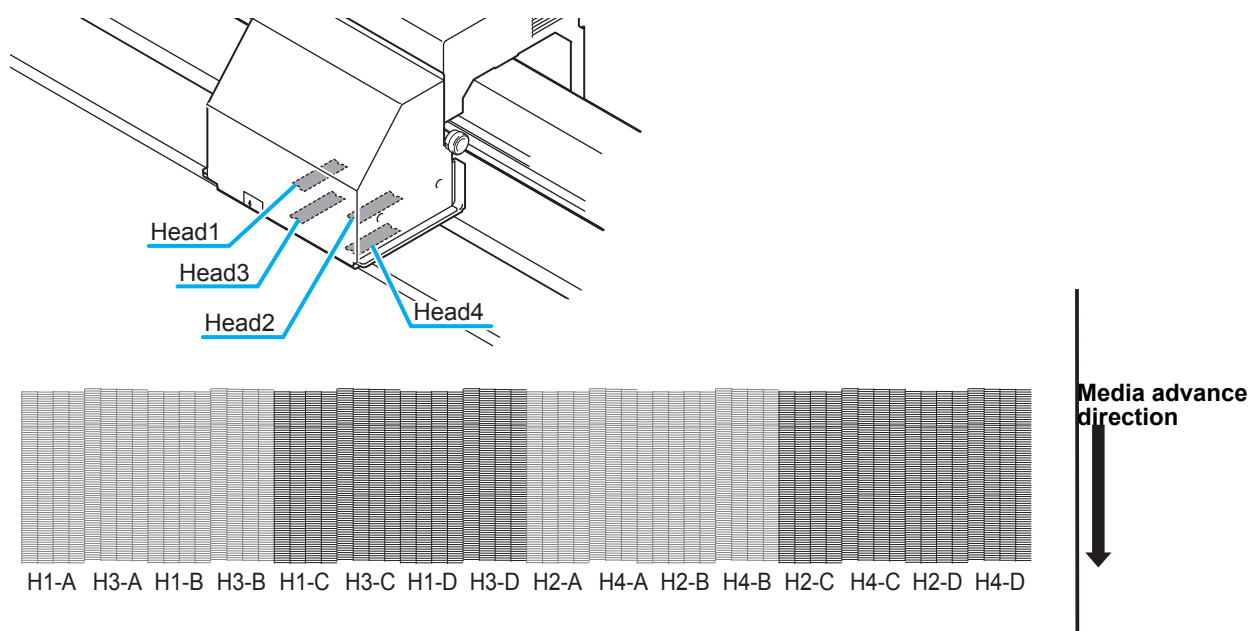

Test Printing

Print a test pattern to check that there are no discharging defects such as nozzle clogging (slight touching of ink or nozzle missing).

Check before test printing.	• If a media has been set P.2-5	• If the origin position has been set
	• If the head height has been adjusted P.2-14	

You can select the orientation of the test pattern to print from two types. Select one depending on your use.

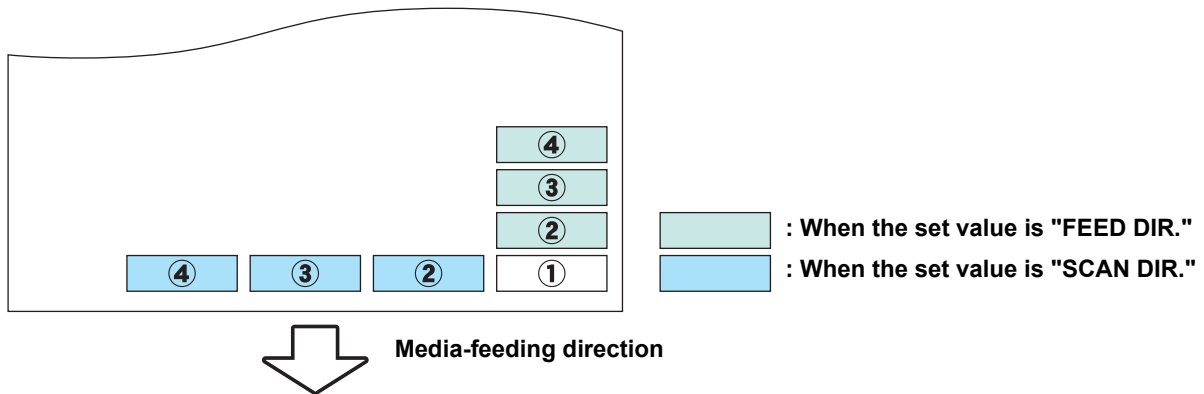

- 1** Press the **TEST PRINT** key in LOCAL.

 - Press , and you can change the nozzle recovery setting (OFF or ON).
 - If you select ON, proceed to the Step 3.

TEST PRINT
 NOZZLE RECOVERY : OFF

- 2** Press the **ENTER** key.

 - Press to change the test pattern orientation.

TEST PRINT
 (FEED DIR.) [ENT]

- 3** Press the **ENTER** key.

 - Test printing starts.
 - When the printing has been completed, the screen returns to LOCAL.

** PRINTING **
 PLEASE WAIT

<LOCAL>
 width : 1272mm

- 4** Check the printed test pattern.

 - When the result is normal, end the operation.
 - When the result is abnormal, perform head cleaning. (P.2-25)

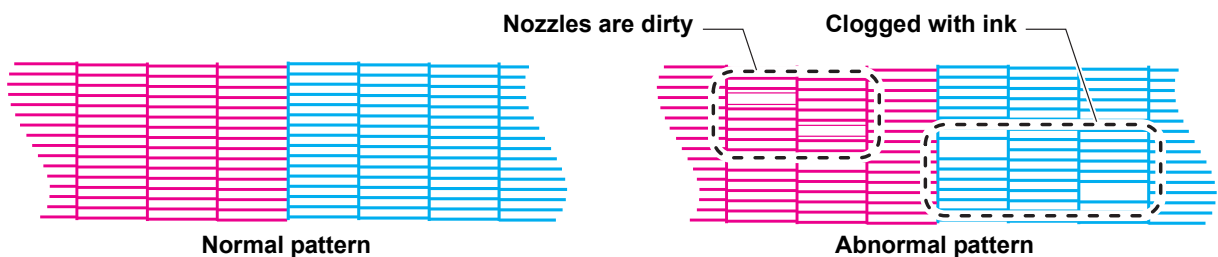

Head Cleaning

About head cleaning

Check the printed test pattern result and perform cleaning depending on the status.
Select one from the three types below:

- SOFT** : When lines are bent, when any line is missing
- NORMAL** : When any line is missing, when colors are mixed
- HARD** : When poor image quality cannot be improved even by NORMAL or SOFT cleaning

Perform head cleaning depending on the test printing result

There are three types of head cleaning. Use one by checking the test pattern.

1 In Local, Press the **CLEANING** key.

CLEANING
SOFT L [ENT]

2 Press **▲** **▼** to select the cleaning type.

- SOFT** : When lines are bent, when any line is missing
- NORMAL** : When any line is missing, when colors are mixed
- HARD** : When poor image quality cannot be improved even by NORMAL or SOFT cleaning

CLEANING
HARD [ENT]

3 Press the **ENTER** key.

SELECT HEAD
: 1 2 3 4

4 Press **▲** **▼** to select a head to use.

- The cleaning of head indicated by the number is carried out.
- Select the head for cleaning by pressing **◀** **▶**, and then select "Cleaning Yes/No" by pressing **▲** **▼**.
- When selecting "Cleaning No", display "_" by pressing **▲** **▼**.

Head array of
SWJ-320S2

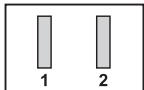

Head array of
SWJ-320S4

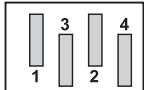

SELECT HEAD
: 1 _ _ _

5 Press the **ENTER** key.

- On completion of cleaning, this machine returns to LOCAL.

** CLEANING **
00:00:00

6 Perform test printing again, and check the result.

- Repeat the cleaning and the test printing until the drawing result becomes in normal.



When the image quality is not improved after the head cleaning.

- Clean the wiper and ink cap. (☞ P.4-5)
- Ink purge (☞ P.4-14)
- Wash the head nozzle. (☞ P.4-16)
- Solve the failure of the image quality, referring to When Nozzle Clogging Cannot Be Solved. (☞ P.4-18)

Set the media feeding

Correct the feeding rate of media.

If the correction value is not appropriate, stripes may appear on the printed image, thus resulting in a poor printing.

Important!

- When you have changed the media type, check the pattern and perform adjustment depending on the status.
- If the heater temperature is changed, start the correction after confirmed by checking the temperature panel of heater that the temperature has reached the set temperature.
- When printing with a take-up device, set the media first and then perform media correction.
- If the adsorption fan is used, start the media correction after turning on the adsorption fan.

Setting Feed Correction

A pattern for media correction is printed and a media-feeding rate is corrected.



- Two bands are printed in the correction pattern.
- Make adjustment so that an even color density is obtained in the boundary between the two bands.

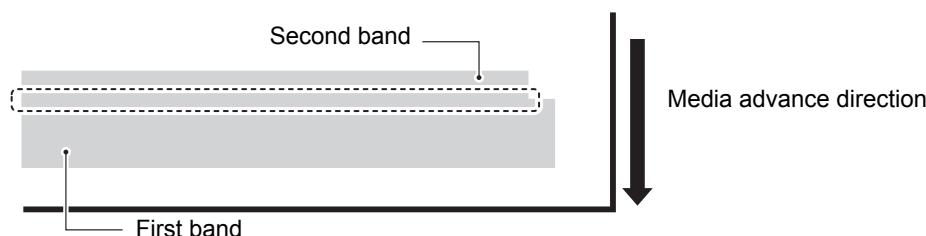

1

Set a media. (👉 P.2-5)

2

Press the **ADJUST** key in LOCAL.

FEED COMP. <ENT>

3

Press the **ENTER** key.

FEED COMP. PRINT [ENT]

4

Press the **ENTER** key to print a correction pattern.

** PRINTING **
PLEASE WAIT

5

Check the correction pattern and enter a correction value.

FEED COMP. = 0

Enter a correction value in "+": The boundary between the two bands is widened.

Enter a correction value in "-": The boundary between the two bands is narrowed.

6

Press the **ENTER** key.

- Print a correction pattern again and check it.
- When media correction is needed, perform the operation in Step 5 to make correction.

```
FEED COMP .
PRINT [ENT]
```

7

Press the **END** key several times to end the setting.

Performing the station maintenance without **ADJUST** key

You can select "FEED COMP." by using the **FUNCTION** key in the Local without pressing the **ADJUST** key.

Press the **FUNCTION** key in Local.

Press **▲** **▼** to select [SETUP].

Press the **ENTER** key twice.

- It becomes the same condition as the key is pressed from Local.

Correcting Media-feeding during Printing

A media-feeding rate can be corrected even in the remote mode or when image data is printed. Specify "ON" for the "Feed Check Pattern" (☞ P.2-28) if you want to check the feeding amount deviation during printing.

1

Press the **FUNCTION** key in the Remote.

```
*REMOTE*
** . **mm
```

```
FEED COMP .
0 ▶ 0
```

Current [FEED COMP.] value

2

Press **▲** **▼** to enter a corrected feeding rate.

- Corrected feeding rate: -255 to 255
- The value entered here is reflected in the corrected feeding rate soon.

3

Press the **ENTER** key.

```
*REMOTE*
** . **mm
```

- The changed value is registered.

Checking the media feeding amount deviation during printing

It is difficult to visually check the feeding amount deviation if the MAPS function is on.

By turning on this function, you can print a pattern on the right edge of the media that serves as a reference for correcting the feeding amount.

Important!

- The print area is reduced by 25 mm if this function is turned on.
- Even if the deviation amount of the pattern is the same, the input correction value varies depending on the printing mode.
Check beforehand to what degree the correction value changes the feeding amount.
- Logical seek is turned off when this function is turned on.
- The following problems might occur if the feeding amount is changed frequently during printing
 1. Total print length is not aligned.
 2. Uneven feeding occurs.

Setting Feed Check Pattern

A pattern for media correction is printed and a media-feeding rate is corrected.

- 1** Set a media. (👉 P.2-5)
- 2** Press the **FUNCTION** key in LOCAL. FUNCTION
SET UP <ENT>
- 3** Press **▲▼** to select the **[MACHINE SETUP]**. FUNCTION
MACHINE SET UP [ENT]
- 4** Press the **ENTER** key. MACHINE SET UP
AUTO Power-off [ENT]
- 5** Press **▲▼** to select **[FeedCheckPatt.]**. FUNCTION
FeedCheckPatt. [ENT]
- 6** Press the **ENTER** key. FeedCheckPattern
:OFF
- 7** Press **▲▼** to set ON/OFF. FeedCheckPattern
:ON
- 8** Press the **ENTER** key.
• The setting is closed if OFF is selected. FeedCheckPattern
PATTERN : 1
- 9** Press **▲▼** to select the print pattern.
• Set Value : PATTERN1 / PATTERN2 FeedCheckPattern
PATTERN : 2

Important!

- The ease with which the deviation amount can be seen depends on the media. Check beforehand that the pattern allows for easily determining the deviation amount.

10 Press the **ENTER** key to close the setting.

- The pattern is printed on the right side of online printing.



- If you have checked the feeding amount deviation during printing, you can press the **ADJUST** key of the remote to correct the feeding amount during printing. (P.2-27)

Overview of Patterns

● Pattern 1

Check the feeding amount deviation by using the solid-fill pattern.

Feeding amount is correct



No gaps between or overlapping of the patterns

Feeding amount is large



Gap in between the patterns

Reduce the feeding correction value

Feeding amount is small



Patterns overlap?

Increase the feeding correction value

● Pattern 2

Check the feeding amount deviation by using overlapping lines.



- This function might be disabled during 3Pass/Pass printing depending on the MAPS speed set value.
MAPS settings that disable this function:
 3Pass: OFF / -40% to +50%
 6Pass: +20% to +50%

Feeding amount is correct

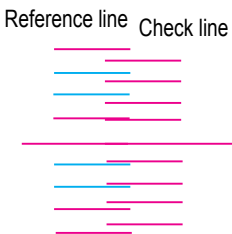

Middle lines are consistent.

Feeding amount is large

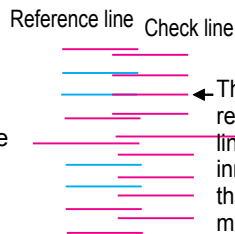

The distance of the reference and check lines on the device inner side are closer than the lines in the middle.

Reduce the feeding correction value

Feeding amount is small

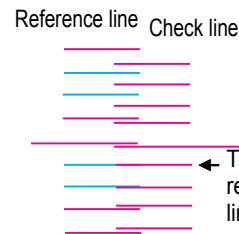

The distance of the reference and check lines on the device outer side are closer

Increase the feeding correction value

Aligning the Print Result Lengths

Apply this correction if the length is excessively long even when applying feed correction when the feed direction is lengthwise.

Important!

- Do not perform feed correction after applying this correction. This correction becomes disabled.
- Even if this correction is applied, the distances will not match if the radius of the media roll being rolled up/let out changes. Re-apply this correction if the roll radius changes.
- Revise this correction if the media type or width changes.
- The following accident error might occur even if this correction is applied.
±Whichever is larger: ±1.5 m or ±0.3% of the specified distance.

Setting Feed Check Pattern

A pattern for media correction is printed and a media-feeding rate is corrected.

- 1** Set a media. (👉 P.2-5)
- 2** Press the **ADJUST** key in LOCAL. FEED COMP .
<ENT>
- 3** Press **▲** **▼** to select the **[X-DistanceComp]**. X-DistanceComp .
[ENT]
- 4** Press the **ENTER** key. X-DistanceComp .
RESOLUTION: 360x600
- 5** Press **▲** **▼** to select resolution.
• Select a resolution that is the same the actual printing. X-DistanceComp .
RESOLUTION: 720x900
- 6** Press the **ENTER** key. X-DistanceComp .
PASS: 6
- 7** Press **▲** **▼** to set number of pass. X-DistanceComp .
PASS: 12
- 8** Press the **ENTER** key. X-DistanceComp .
SCAN SPEED: HIGH
- 9** Press **▲** **▼** to set scan speed. X-DistanceComp .
SCAN SPEED: NORMAL

Important!

- Select a speed that is the same the actual printing.
- Not displayed for print modes that cannot scan at high speed.

10 Press the **ENTER** key.

X-DistanceComp.
LENGTH: 400mm

11 Press **▲** **▼** to set print length.

X-DistanceComp.
LENGTH: 500mm

Important! • The precision of the feeding correction increases as the print length is longer.

12 Press the **ENTER** key.

X-DistanceComp.
PRINT [ENT]

13 Press the **ENTER** key to print a correction pattern.

** PRINTING **
PLEASE WAIT

Important! • Printed in the middle of the media.

14 Press the **ENTER** key to print a correction pattern.

MEASUREMENT
= 396.00

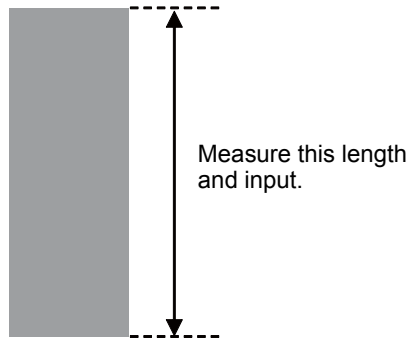

15 Press the **ENTER** key.

16 Press the **END** key several times to end the setting.

Correct the ink drop position for bidirectional printing

When the condition for printing (media thickness/head height/etc.) has been changed, perform the following operation to correct the ink drop position for bidirectional (Bi) printing and obtain the proper printing result.

Example of a Drop Position correct Printed Pattern

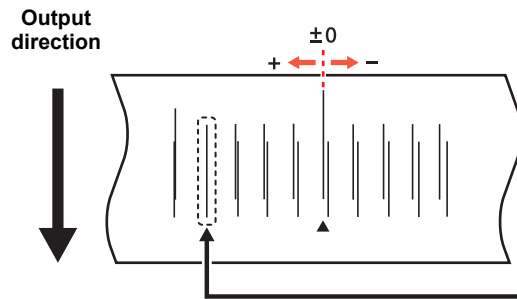

The dots at the fourth position counted from the zero position in the positive direction form a straight line. In this case, the dot position correction value is 4.0.

1

Set a media on the machine and set a printing origin. (👉 P.2-5)

2

Press the **ADJUST** key twice in LOCAL.

DROP.POScorrect
[ENT]

3

Press the **ENTER** key.

DROP.POScorrect
:Y540dpi

4

Press the **▲** **▼** to select the resolution.

• Set value : Y360dpi/ Y540dpi/ Y720dpi/ Y1080dpi

DROP.POScorrect
:Y540dpi

5

Press the **ENTER** key.

DROP.POScorrect
PRINT [ENT]

6

Press the **ENTER** key to start pattern printing.

• The printed patterns are called Pattern 1, Pattern 2, Pattern 3... in the order of printing.

** PRINTING **
PLEASE WAIT

7

Press **▲** **▼** to correct the dot position of Pattern 1~.

- Corrected feeding rate: -40.0 to 40.0
- Check the test patterns. The position where an outward feeding line and a return feeding line become one straight line is the correction value.
- When the correction value is not between -40.0 and 40.0, adjust the height of the printing heads and then perform the operations in Step 2 and later.

PATTERN1
= 0.0

8 Press the **ENTER** key.

9 Press the **END** key several times to end the setting.

Performing to correct the dot position without **ADJUST** key

You can select "DROP.POScorrect" by using the **FUNCTION** key in the Local without pressing the **ADJUST** key.

Press the **FUNCTION** key in Local.

Press **▲** **▼** to select [SETUP], and press the **ENTER** key.

Press **▲** **▼** to select [DROP.POScorrect], and press the **ENTER** key twice.

- It becomes the same condition as the key is pressed from Local.

Printing Data

Starting a Printing Operation

Important!

- When using a roll media, rewind the media before printing so that it is not loose. When the roll media has not been rewound tightly, it may cause the image quality to deteriorate.

1

Setting a Media (☞ P.2-5)

2

Transmit data to be printed from the PC.

- The ACTIVE lamp blinks and the printing conditions are displayed.
- For the method of data transmission, see the instruction manual for the output software.

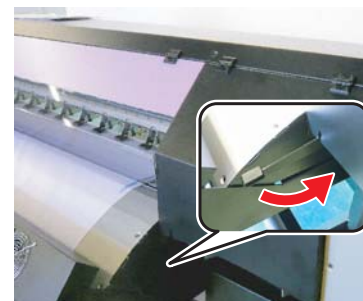

3

Start printing.

Resolution : 700 / 600 DPI

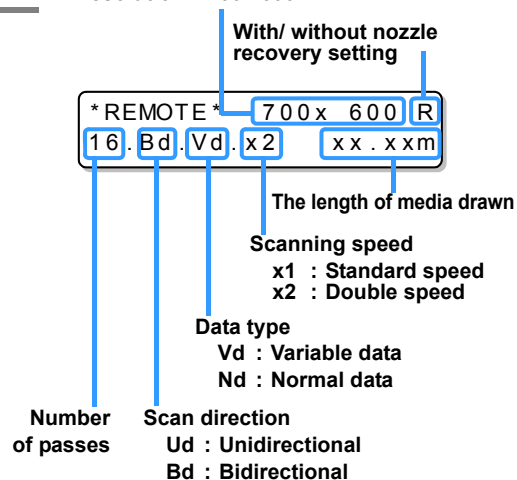

Printing mode list

X resolution	Y resolution	Pass	Double speed scan ^{*1}	Maximum printing width ^{*2}	
360dpi	600dpi	2	x	3,200mm	
		4	O		
		8	O		
720dpi	600dpi	2	x		
		4	O		
		8	O		
	900dpi	3	x		
		6	O		
		12	O		
1080dpi	600dpi	2	x		3,000mm
		4	O		
		8	O		
	900dpi	3	x		
		6	O		
		12	O		

*1. In the printing mode with O mark, you can print with either of "Double speed" and "Standard speed". In the printing mode with X mark, you cannot print with "Double speed scan". You can use only "Standard speed".

*2. For 1,080dpi of Y resolution, the maximum printing width is 3,000mm. If you want to perform printing of 3,200mm-width, use 360dpi/ 720dpi to print.

Stopping a printing operation halfway

Perform the following operation when stopping a printing operation halfway.

1

Press the **REMOTE** key during printing.

- The printing operation stops.
- Interrupt data sending at the PC side during the data is sent from the PC.
- Printing restarts from the interrupted data by repressing the **REMOTE** key.

```
<LOCAL>
width:1272mm
```

Deleting Received Data (Data Clear)

When you want to stop printing, delete the already received data.

1

Press the **DATA CLEAR** key in LOCAL.

```
DATA CLEAR
[ENT]
```

2

Press the **ENTER** key.

- The ACTIVE lamp goes out.
- The received data is erased then it returns to the local mode.

```
** DATA CLEAR **
```

2

Using method of weight for assistant roller

When ruck occurs on the media on the platen, you can put the weight on the assistant roller to reduce the height of ruck.

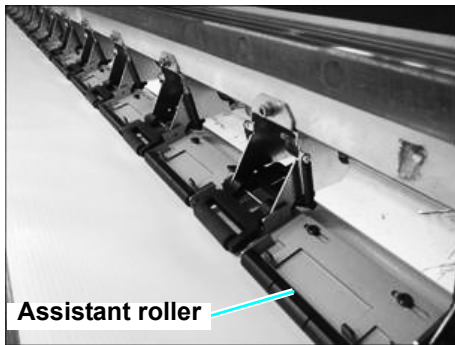

3 Put the weight on the assistant roller Assy, and slide it to the front until it hits the protrusion.



- You can put up to three weights on one assistant roller Assy.

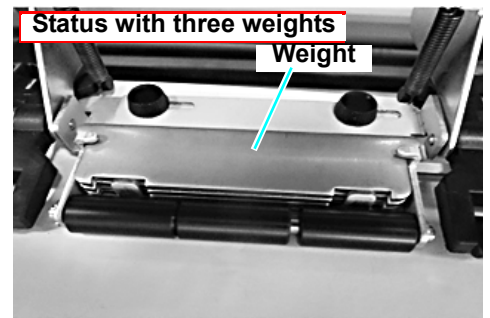
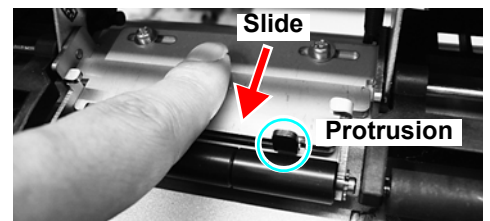

Important!

- If you put the weight too much, ruck may be increased unnecessarily.
- While checking occurrence of ruck during printing, increase the weight gradually from 0, and use the machine having the weight with which the media has least ruck.

Chapter 3

Extended Functions



This chapter

describes the operation procedures for using the machine more conveniently and each setting procedure.

List of Functions	3-2	Machine Settings	3-12
Setting Logical Seek	3-3	Setting a AUTO Power-off	3-13
Setting Drying Time	3-4	Setting the Display of Media Residual	3-14
Perform setting to reduce stripes between passes	3-5	Setting the Feed Compensation Mode	3-16
Setting Auto Cleaning	3-7	Setting Time.....	3-17
Setting nozzle face cleaning time	3-8	Setting Units	3-18
Set the scanning speed and the feeding speed during printing	3-9	Setting a KEY BUZZER.....	3-19
Other Settings	3-11	Setting a LANGUAGE.....	3-20
		Initializing the Settings	3-21
		Confirming Machine Information	3-22
		Displaying the Information	3-22
		Displaying the Information of this machine .	3-23

List of Functions

This section describes the overview of each function to be set and set values that can be registered in user types.



• **About default “HOST” function**

You can operate this by the setting value specified in RIP software.

When you set to other than “HOST”, it operates by that setting value, not by the instruction from RIP software.

Depending on RIP software, there are some functions that cannot be instructed by software. In such a case, it operates by the setting value of “When no instruction from RIP exists”.

- For the specifying method with the RIP software, refer to the operation manual of the RIP software.

Function name		Set value	Default	When no instruction from RIP exists *1	Outline
FEED COMP. (☞ P.2-26)		-9999 ~ 0 ~ 9999	0	—————	Used to print a pattern for correcting a media-feeding rate and correct it.
DROP. POS CORRECT		-40.0 ~ 0 ~ 40.0	0	—————	Used to adjust the dot position in go and return printing.
LOGICAL SEEK(☞ P.3-3)		HOST / ON / OFF	HOST	OFF	Sets the scan movable area during printing.
INK LAYERS (☞ P.3-11)		HOST / 1 ~ 9	HOST	1	Sets the number of layers in which ink is to be applied.
DRYING TIME (☞ P.3-3)	SCAN	HOST / 0.0 ~ 99 sec	HOST	0.2 sec	Sets the time to wait for ink drying.
	PRINT END	HOST / 0 ~ 999 sec	HOST	0 sec	
REFRESH		HOST / Lv.0 ~ Lv.3	Lv.3	Lv.3	Sets the refreshing operation to stabilize the nozzle condition in printing.
PRINT SPEED (☞ P.3-11)	SCAN SPEED	70 ~ 100%	100%	—————	Changes the print head moving speed and the media feeding speed during printing.*2
	FEED SPEED	HOST / 10 ~ 300%	HOST	100%	
MAPS (☞ P.3-5)	OFF / ON		OFF	—————	Perform setting to reduce stripes between passes.
	PRINT SPEED ADJUST	-50 ~ +50%	0%	—————	
AUTO CLEANING (☞ P.3-7)	PAGE	OFF / 1~1000	OFF	—————	Sets the automatic cleaning operation of the head at the start of printing.
	LENGTH	OFF / 0.1~100m	OFF	—————	
INTERVAL WIPING(☞ P.3-8)		AUTO, 10~2540s, OFF	AUTO	—————	Sets the wiping operation during printing.

*1. This is the setting value to be used for printing when setting value is not specified at the RIP software (host) side, or, you give priority to the setting value at the machine side, even if you set “Host” to the type registration of this machine.

*2. When you set “FEED SPEED” to “100%” or more, required time for completion of printing will be shortened. However, enough drying time cannot be ensured and it may affect the image quality. In addition, when you set “FEED SPEED” to “100%” or more, the media feeding accuracy may be degraded.

Setting Logical Seek

The motion of Head varies depending on the set of Logical-seek.

Important!

- You cannot specify the logical seek at the RasterLinkPro side. When you set this machine to "Host", printing will be performed in "LOGICAL SEEK=ON" status.
- When you set this to "OFF"
The time to the print completion gets longer, but no difference occurs in the drying condition depending on the data width.

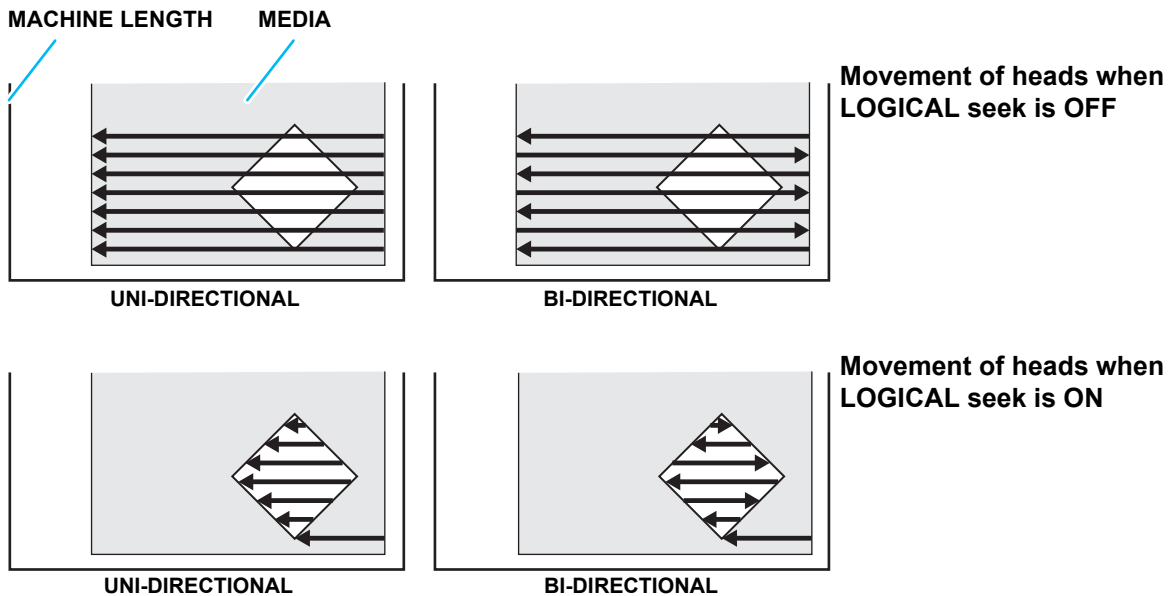

- Press the **FUNCTION** key in LOCAL.

FUNCTION
SETUP [ENT]
- Press the **ENTER** key.

SETUP
FEED COMP. [ENT]
- Press **▲ ▼** to select [LOGICAL SEEK].

SETUP
LOGICAL SEEK [ENT]
- Press the **ENTER** key.

LOGICAL SEEK
:HOST
- Press **▲ ▼** to select a set value.
• Set value : HOST / ON / MEDIA LENGTH / MACHINE LENGTH

LOGICAL SEEK
:OFF
- Press the **ENTER** key.

SETUP
LOGICAL SEEK [ENT]
- Press the **END** key several times to end the setting.

Setting Drying Time

In the drying time setting, the following items for ink drying time are set.

- SCAN : Ink drying time for each scanning is set. (During bidirectional printing, the machine stops for a certain period of time specified for each of the outward and return scanning.)
- PRINT END : Ink drying time after printing has been complete is set.

Important!

- When you give priority to the setting at the RasterLinkPro side, make the setting value "Host".
- "SCAN" set in this machine is displayed as "Pause Time per Scan" in the RasterLinkPro.
- You cannot specify the print end at the RasterLinkPro side. When you set this machine to "Host", printing will be performed in "PRINT END= 0 sec." status.

1	Press the FUNCTION key in LOCAL.	FUNCTION SETUP [ENT]
2	Press the ENTER key.	SETUP FEED COMP. [ENT]
3	Press ▲▼ to select [DRYING TIME].	SETUP DRYING TIME [ENT]
4	Press the ENTER key.	SCAN = HOST
5	Press ▲▼ to set drying time for scanning. • To enable the drying time specified in your RIP, select "Host". • Scanning setting value : Host or 0.0 sec. to 99 sec.	SCAN = HOST
6	Press the ENTER key.	PRINT END = HOST
7	Press ▲▼ to set drying time for after printing is completed. • To enable the drying time specified in your RIP, select "Host". • Print end setting value : Host or 0 sec. to 999 sec.	PRINT END = HOST
8	Press the ENTER key.	SETUP DRYING TIME [ENT]
9	Press the END key several times to end the setting.	

Perform setting to reduce stripes between passes

In case that feeding stripes cannot be resolved even though media correction (☞ P.2-26) is performed, make "MAPS (Mimaki Advanced Pass System) valid. Feeding stripes become less visible by distributing the pass boundary. (Supported from the firmware ver.2.00)



- The color might change if MAPS is enabled. Check this beforehand.
- MAPS effect differs depending on the set value of the printing speed. Use it after checking effect in advance.
- When you speed up the printing speed, it takes shorter time to print. However, MAPS effect becomes weak.
- When you slow down the printing speed, it takes longer time to print. However, MAPS effect becomes strong and feeding stripes become less visible.
- When printing, if you set the printing speed to 0% and more, MAPS becomes invalid. In addition, it prints at 0% speed. When you use MAPS, set the printing speed to "minus (-)".

Resolution	Pass	Scan speed
360x600	2Pass	Normal speed
540x600	2Pass	Normal speed
720x600	2Pass	Normal speed
720x600	4Pass	High speed
720x900	3Pass	Normal speed
720x900	6Pass	High speed

Resolution	Pass	Scan speed
1080x600	2Pass	Normal speed
1080x600	4Pass	High speed
1080x900	3Pass	Normal speed
1080x900	6Pass	High speed
1080x1200	4Pass	Normal speed
1080x1200	8Pass	High speed

1 Press the **FUNCTION** key in LOCAL. FUNCTION
SETUP [ENT]

2 Press the **ENTER** key. SETUP
FEED COMP . [ENT]

3 Press **▲ ▼** to select [MAPS]. SETUP
MAPS [ENT]

4 Press the **ENTER** key. MAPS
: OFF

5 Press **▲ ▼** to set ON/OFF. MAPS
: ON
• Set Value : OFF, ON

6 Press the **ENTER** key. MAPS
PATTERN : 1
• When you select OFF, proceed to the Step 11.

7 Press **▲ ▼** to change print pattern. MAPS
PATTERN : 1
• Set Value : PATTERN1 / PATTERN2



- The MAPS effectiveness varies depending on the printed image. When changing the print pattern, check the effectiveness before using the MAPS function.

8 Press the **ENTER** key. PRINT SPEED ADJUST
= 0%

3 Convenient use

9

Press   to change print speed.

• Set Value : -50 ~ +50%

 Important!

• When you speed up, nozzle recovery effect cannot work in some cases. Use it after checking.

PRINT SPEED ADJUST
= 10%

10

Press the  key.

SETUP
MAPS [ENT]

11

Press the  key several times to end the setting.

Setting Auto Cleaning

You can set up to perform the head cleaning automatically after the print of the pre-set number of pages or distance was completed.

- 1** Press the **FUNCTION** key in LOCAL. FUNCTION
SETUP [ENT]
- 2** Press the **ENTER** key. SETUP
FEED COMP. [ENT]
- 3** Press **▲▼** to select **[AUTO CLEANING]**. SETUP
AUTO CLEANING [ENT]
- 4** Press the **ENTER** key. SETUP
AUTO CLEANING [ENT]
- 5** Press the **▲▼** to select the **[PAGE]** or **[LENGTH]**. AUTO CLEANING
: PAGE
AUTO CLEANING
: LENGTH
- 6** Press the **ENTER** key. INTERVAL
= OFF
- 7** Press **▲▼** to set a cleaning interval.
 - Set value PAGE: OFF / 1 to 1000 page
 - LENGTH: OFF / 0.1 to 100 m
 - When selecting OFF, proceed to Step 10.INTERVAL
= 1 page
INTERVAL
= 0.1m
- 8** Press the **ENTER** key. TYPE
: SOFT
- 9** Press **▲▼** to set a cleaning type.
 - Set value : NORMAL / SOFT / HARDTYPE
: NORMAL
- 10** Press the **ENTER** key.
- 11** Press the **END** key several times to end the setting.

Important!

- Depending on the state of the heads, etc., the image quality deterioration may not be improved even with this function performed. In this case, contact our service office or the distributor in your region.

Setting nozzle face cleaning time

When the set time has passed, nozzle face of the head is cleaned automatically to remove ink droplets on the nozzle face.

In case that deflection, nozzle missing, or symptom which ink droplets fall down occurred, make the interval between each operation shorter.

1	Press the FUNCTION key in LOCAL.	FUNCTION SETUP [ENT]
2	Press the ENTER key.	SETUP FEED COMP. [ENT]
3	Press ▲ ▼ to select [INTERVAL WIPING].	SETUP INTERVAL WIPING [ENT]
4	Press the ENTER key.	INTERVAL WIPING : AUTO
5	Press ▲ ▼ to set intervals. • Set Value : AUTO, Seconds, OFF • When [OFF] is set, periodical wiping is not executed.	INTERVAL WIPING : AUTO
6	Press the ENTER key.	SETUP INTERVAL WIPING [ENT]
7	Press the END key several times to end the setting.	

Set the scanning speed and the feeding speed during printing

Set the print head moving speed and the media feeding speed during printing.

● SCAN SPEED

Set the print head moving speed during printing.

If you print in a hot environment or when you print a thick data, nozzle missing may occur in a short time. At this time, change the scanning speed setting.

By slowing down the scanning speed, you can reduce nozzle missing.

● FEED SPEED

Set the media feeding speed during printing.

By speeding up the feeding speed, it takes less time to complete printing. However, the media feeding accuracy may be degraded.

In addition, as dryness time of printing becomes shorter, fully check on the media you use before changing the setting.

1	Press the FUNCTION key in LOCAL.	FUNCTION SETUP [ENT]
2	Press the ENTER key.	SETUP FEED COMP. [ENT]
3	Press ▲▼ to select [PRINT SPEED].	SETUP PRINT SPEED [ENT]
4	Press the ENTER key.	PRINT SPEED : 360dpi
5	Press ▲▼ to set resolution. • Set Value : 540dpi, 720dpi, 1080dpi	PRINT SPEED : 360dpi
6	Press the ENTER key.	SCAN SPEED = 100%
7	Press ▲▼ to set scan speed. • Set Value : 70% to 100%	SCAN SPEED = 100%
8	Press the ENTER key.	FEED SPEED = HOST

9

Press   to set feed speed.

• Set Value : HOST/70% to 100%

FEED SPEED	
=	HOST

10

Press the  key.

SETUP	
PRINT SPEED	[ENT]

11

Press the  key several times to end the setting.

Important!

- When you slow down the scanning speed, it takes more time to complete printing. If you want to prevent the printing speed from slowing down, perform setting of the feeding speed depending on the scanning speed setting by referring to the table below:
- When you set the feeding speed to 100% and more, the media feeding accuracy may be degraded. Be sure to check on the media you use before changing the feeding speed.
- The values in the table below are the reference when the printing area is 3,200mm. The printing speed changes depending on the printing area width, the media setting position and the data to be printed. Check in advance before changing the feeding speed.

Reference value of feeding speed corresponding to each scanning speed to make printing speed same (for 3,200mm wide printing)

Scan Speed			SWJ-320S2			SWJ-320S4		
			70%	80%	90%	70%	80%	90%
540x600dpi	2pass	Bi	*1	*1	300%	*1	300%	130%
	4pass	Bi	*1	*1	*1	*1	*1	300%
	8pass	Bi	*1	*1	*1	*1		*1
720x600dpi	2pass	Bi	*1	*1	300%	*1		150%
	4pass	Bi	*1	*1	300%	*1		300%
	8pass	Bi	*1	*1	300%	*1		*1
720x600dpi Hi speed	4pass	Bi	*1	*1	300%	*1		150%
	8pass	Bi	*1	*1	300%	*1		300%

*1: Condition when printing speed does not become the same even if you set the feeding speed to 300%

Other Settings

Change the settings according to the types of use.

1

Press the **FUNCTION** key in LOCAL.

FUNCTION
SETUP [ENT]

2

Press the **ENTER** key.

SETUP
FEED COMP. [ENT]

3

Press **▲** **▼** to select an item for setting.

- Select it, referring to P.3-2 "List of Functions".

4

Press the **ENTER** key.

5

Press **▲** **▼** to select the setting value.

- Select it, referring to P.3-2 "List of Functions".

6

Press the **ENTER** key.

7

Press the **END** key several times to end the setting.

Important!

- The set value is retained even when the power is turned "OFF".

Machine Settings

Common settings are functions for using this machine easily.
The following items can be set in Machine settings.

Item		Set value	Default	Meaning
AUTO Power-off		NONE/ 10 ~ 600min	30min	When no operation has been performed for the set time, the power supply is automatically turned "OFF".
MEDIA RESIDUAL		ON / OFF	OFF	You can control the remaining amount of media.
FeedCheckPatt.		ON / OFF	OFF	You can set the feed check pattern for printing.
FEED COMP. MODE		MODE1 / MODE2	MODE1	Set the feed compensation mode.
TIME		+4h ~ -20h	Japan time	Time difference is corrected.
UNIT	TEMP.	°C (Centigrade) /°F (Fahrenheit)	°C	A unit for displaying temperature is set.
	LENGTH	mm / inch	mm	A unit for displaying length and area is set.
KEY BUZZER		OFF / ON	ON	A buzzer sound when keys are pressed is set.
LANGUAGE		English / Japanese	English	Displayed language is changed.
RESET( P.3-21)		_____	_____	All setting values are returned to the status default.

Setting a AUTO Power-off

When no operation has been performed for the set time, the power supply is automatically turned "OFF".

1

Press the **FUNCTION** key in LOCAL.

```
FUNCTION
SETUP [ENT]
```

2

Press **▲** **▼** to select [MACHINE SETUP].

```
FUNCTION
MACHINE SETUP [ENT]
```

3

Press the **ENTER** key twice.

```
AETO Power - off
= 30min
```

4

Press **▲** **▼** to set time to turn OFF the power supply.

```
AETO Power - off
= 60min
```

• Set Value : none, 10 to 600min

5

Press the **ENTER** key.

```
MACHINE SETUP
AUTO Power - off [ENT]
```

6

Press the **END** key several times to end the setting.

Setting the Display of Media Residual

Whether the screen displays the remaining amount of a media is set.

When the media remaining amount display is turned to "ON"	the remaining amount of a media is displayed in Remote. (However, when a leaf media is used, the length of the media to be printed is displayed.)
When the media remaining amount display is turned to "OFF"	the remaining amount of a media is not displayed in the Remote.



- The amount of a media that has been fed by the printing and jog keys is reflected in the remaining amount of a media.
- The length of a media (initial value of the remaining amount) is entered when a roll media is detected. (P.2-16)
- The setting configured here does not become effective unless media detection is performed after the setting has been complete.

1

Press the **FUNCTION** key in LOCAL.

FUNCTION
SETUP [ENT]

2

Press **▲** **▼** to select [MACHINE SETUP].

FUNCTION
MACHINE SETUP [ENT]

3

Press the **ENTER** key.

MACHINE SETUP
AUTO Power-off [ENT]

4

Press **▲** **▼** to select [MEDIA RESIDUAL].

MACHINE SETUP
MEDIA RESIDUAL [ENT]

5

Press the **ENTER** key.

MEDIA RESIDUAL
: OFF

6

Press **▲** **▼** to select ON/OFF.

MEDIA RESIDUAL
: ON

7

Press the **ENTER** key.

MACHINE SETUP
MEDIA RESIDUAL [ENT]

8

Press the **END** key several times to end the setting.

Printing the Remaining Amount of a Media

The present remaining amount of a media can be printed.



- Set "Remaining amount of a media to display" to "ON".
- When you replace the media you use now with another, it is recommended that you print the remaining amount of the media on it. With the remaining amount of a media having been printed beforehand, when you use the replaced media again, you can enter an accurate value in the screen for entering the remaining amount of a media (P.2-16) that appears after media detection.

1









In LOCAL, Press    .

- LOCAL changes to the origin setting mode.

ORIGIN SETUP
0.0 ----

2





Set the arrow of carriage to the position to change by pressing    .

- Move the carriage and media with     and set the origin.
- When you do not change the origin, do not press     and proceed to Step 3.
- When you press the  key here, the origin is changed, and the screen returns to LOCAL.

ORIGIN SETUP
0.0 0.0
Origin (Length) Origin (Width)

3

Press the  key.

- When you press     , the screen returns to Step 2.
- When you press the  key, the screen returns to LOCAL.

MEDIA RESIDUAL DRAW
<ENT>

4

Press the  key.

- The remaining amount of a media starts to be printed.
- When the printing has been completed, the screen returns to LOCAL.

Important!

- When the remaining amount of a media has been printed with the origin changed, the origin set here is effective even when subsequent data are printed.

3

Convenient use

Setting the Feed Compensation Mode

You can select the compensation mode for media feed.

If you select MODE1	Feed Compensation is available either for Feed Correction (☞ P.2-26) or Feed Check Pattern (☞ P.2-30).
If you select MODE2	Feed Correction (☞ P.2-26) is available only for Feed Correction. (The Feed Check Pattern Menu will no longer be displayed.)

Important!

- Correcting Media-feeding(☞ P.2-27) during printing is available in any MODE.
- If you run any compensation process in MODE1, the feed compensation value during printing will be 0.
- If you run any compensation process in MODE2, The feed compensation value during printing and the compensation value for Feed Correction (☞ P.2-26) are the same.

1

Press the **FUNCTION** key in LOCAL.

FUNCTION
SETUP [ENT]

2

Press **▲** **▼** to select [MACHINE SETUP].

FUNCTION
MACHINE SETUP [ENT]

3

Press the **ENTER** key.

MACHINE SETUP
AUTO Power-off [ENT]

4

Press **▲** **▼** to select [FEED COMP. MODE].

MACHINE SETUP
FEED COMP. MODE [ENT]

5

Press the **ENTER** key.

FEED COMP. MODE
: MODE1

6

Press **▲** **▼** to select MODE1/MODE2.

FEED COMP. MODE
: MODE2

7

Press the **ENTER** key.

MACHINE SETUP
FEED COMP. MODE [ENT]

8

Press the **END** key several times to end the setting.

Setting Time

You can set time of your country (time difference).

- 1** Press the **FUNCTION** key in LOCAL.

FUNCTION
SETUP [ENT]
- 2** Press **▲** **▼** to select [MACHINE SETUP].

FUNCTION
MACHINE SETUP [ENT]
- 3** Press the **ENTER** key.

MACHINE SETUP
AUTO Power-off [ENT]
- 4** Press **▲** **▼** to select [TIME].

MACHINE SETUP
TIME [ENT]
- 5** Press the **ENTER** key.

TIME
2011.10.05 21:30:00
- 6** Press **▲** **▼** **◀** **▶** to enter time.
 Year/Month/Day/Time selecting: by the **◀** **▶** keys.
 Year/Month/Day/Time inputting: by the **▲** **▼** keys.
- 7** Press the **ENTER** key.
 • The entered date is displayed.

TIME
2011.10.05 15:30:00
- 8** Press the **END** key several times to end the setting.



- -20 hours to +4 hours can be set.

Setting Units

Units used by this machine are set.

- 1** Press the key **FUNCTION** in LOCAL. FUNCTION
SETUP [ENT]
- 2** Press **▲▼** to select [MACHINE SETUP]. FUNCTION
MACHINE SETUP [ENT]
- 3** Press the **ENTER** key. MACHINE SETUP
AUTO Power-off [ENT]
- 4** Press **▲▼** to select [UNIT]. MACHINE SETUP
UNIT [ENT]
- 5** Press the **ENTER** key. TEMP
: °C
- 6** Press **▲▼** to select a unit of the temperature.
• Set value : °C / °F
- 7** Press the **ENTER** key. LENGTH
: mm
- 8** Press **▲▼** to select a unit of the length.
• Set value : mm / inch
- 9** Press the **ENTER** key. MACHINE SETUP
UNIT [ENT]
- 10** Press the **END** key several times to end the setting.

Setting a KEY BUZZER

You can turn off the buzzer sound when pressing the key.

1	Press the FUNCTION key in LOCAL.	FUNCTION SETUP <ENT>
2	Press ▲ ▼ to select [MACHINE SETUP].	FUNCTION MACHINE SETUP [ENT]
3	Press the ENTER key.	MACHINE SETUP AUTO Power-off [ENT]
4	Press ▲ ▼ to select [KEY BUZZER].	MACHINE SETUP KEY BUZZER [ENT]
5	Press the ENTER key.	KEY BUZZER :ON
6	Press ▲ ▼ to select ON/OFF.	KEY BUZZER :OFF
7	Press the ENTER key.	MACHINE SETUP KEY BUZZER [ENT]
8	Press the END key several times to end the setting.	



- When the key buzzer is set to "OFF", the buzzer sound for errors, warnings, operation completion, etc. cannot be shut off.





Setting a LANGUAGE

You can change the displayed language.

- | | | |
|---|------------------------------------------------------------|---------------------------------------|
| 1 | Press the FUNCTION key in LOCAL. | FUNCTION
SETUP [ENT] |
| 2 | Press ▲ ▼ to select [MACHINE SETUP]. | FUNCTION
MACHINE SETUP [ENT] |
| 3 | Press the ENTER key. | MACHINE SETUP
AUTO Power-off [ENT] |
| 4 | Press ▲ ▼ to select [LANGUAGE]. | MACHINE SETUP
LANGUAGE [ENT] |
| 5 | Press the ENTER key. | LANGUAGE
: English |
| 6 | Press ▲ ▼ to select language. | MEDIA S IDUAL
: ニホンゴ |
| 7 | Press the ENTER key. | MACHINE SETUP
LANGUAGE [ENT] |
| 8 | Press the END key several times to end the setting. | |

Initializing the Settings

You can return the setting of "SETUP", "MAINTENANCE" and "MACHINE SETUP" to the status before shipment.

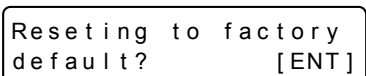
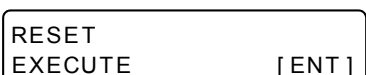
- 1** Press the **FUNCTION** key in LOCAL. 
- 2** Press **▲▼** to select **[MACHINE SETUP]**. 
- 3** Press the **ENTER** key. 
- 4** Press **▲▼** to select **[RESET]**. 
- 5** Press the **ENTER** key. 
- 6** Press the **ENTER** key.
 - The already configured settings are initialized.
- 7** Press the **END** key several times to end the setting.

Confirming Machine Information

The information of this machine can be confirmed.
The following items can be confirmed as machine information.

Item	Description
USAGE	WIPING
	PRINT LENGTH
	PRINT AREA
	USE TIME
VERSION	This displays the firmware version of the machine.
LIST	This prints the setting contents of the machine.

Displaying the Information

1

Press the **FUNCTION** key in LOCAL.

FUNCTION
SETUP [ENT]

2

Press **▲** **▼** to select [INFORMATION].

FUNCTION
INFORMATION [ENT]

3

Press the **ENTER** key.

INFORMATION
USAGE [ENT]

4

Press **▲** **▼** to select a type of information.

5

Press the **ENTER** key.

- The Information you need is displayed.

About Displayed Information

This section describes how to read displayed information.

WIPING Displays wiping information. WIPING = 0	PRINT LENGTH Displays printed length up to now. PRINT LENGTH = 0m
PRINT AREA Displays printed area up to now. PRINT AREA = 0m ²	USE TIME Displays used time information of machine. USE TIME = 0h

Displaying the Information of this machine

1 Press the **ENTER** key in LOCAL.

*** INK	MCYK
REMAIN	9999

2 The information is displayed sequentially with the **ENTER** key .

- The information shown on the below appear.

Remaining amount of ink *** INK MCYK REMAIN 9999	Error (when ink error occurs) INK NEAR END MCYK	Warning (when warning occurs) WARNING Replace a Wiper [MNT]
Media width MEDIA WIDTH = 1000mm	Serial No. SERIAL No . : *****	Version SWJ - 320 V1.00 MRL - III V1.80

RECOVERY NOZZLE

RECOVERY NOZZLE CONFIRM DETAILS [MNT]

Press the **MAINT.** key and confirm the description

3 Press the **ENTER** key to return to LOCAL.

3 Convenient use

Chapter 4

Maintenance



This chapter

describes the items required to use this machine more comfortably, which are the methods for the daily care, the maintenance of the ink unit etc.







Maintenance	4-2	When Nozzle Clogging Cannot Be Solved ..	4-14
Precautions for Maintenance	4-2	Ink purge	4-14
About Cleaning Solution	4-2	Washing of Head nozzle	4-16
Cleaning the Exterior Surfaces	4-3	Alternative nozzles for printing, when nozzles	
Cleaning the Platen	4-3	missing can not be improved	4-18
Cleaning of after heater cover and pre		Automatic Maintenance Function	4-25
heater cover	4-3	Setting the Refreshing Intervals	4-25
Cleaning the Media Holder	4-4	Setting the Cleaning Intervals	4-26
Maintaining the Capping Station	4-5	Replacing consumables	4-27
Cleaning the Wiper and Cap	4-5	Replacing the wiper	4-27
Washing the Ink Discharge Passage		Replace the waste ink tank with another ...	4-28
(DISWAY WASH)	4-8	Replacing the fan filter	4-29
When the Machine Is Not Used for a			
Long Time (CUSTODY WASH)	4-9		
Cleaning the Ink Head and the Area			
around It	4-12		

Maintenance

Maintain the machine regularly or as necessary so that its accuracy will be maintained and it can continue to be used for a long time.

Precautions for Maintenance

Pay attention to the following items when maintaining this machine.

	<ul style="list-style-type: none"> When using cleaning solution for maintenance, be sure to wear the supplied protective glasses.
	<ul style="list-style-type: none"> The ink contains organic solvent. When cleaning the machine, be sure to wear gloves so that no ink will make direct contact with your skin.
	<ul style="list-style-type: none"> Never disassemble the machine. Disassembling it can result in electric shock hazards or damage to the machine. Before maintenance, be sure to turn off the power switch and main power switch, and unplug the power cable; otherwise, an unexpected accident may occur.
	<ul style="list-style-type: none"> Prevent moisture from entering the machine. Moisture inside the machine can cause electric shock hazards or damage to the machine.
	<ul style="list-style-type: none"> To ensure stable ink jetting, it is necessary for the machine to eject a small amount of ink (flushing) regularly when a printing (outputting) operation has not been performed for a long time. When the machine is not to be used for a long time, turn off only the power switch on the front side, leave the main power switch at the side turned ON (in the position of), and leave the power cable connected.
	<ul style="list-style-type: none"> If organic solvent ink is mixed with water or alcohol, coagulation is generated. Do not wipe the nozzle face of the heads, wiper, caps, etc. with water or alcohol. Doing so can cause nozzle clogging or machine failure. Do not use benzene, thinner, or any chemical agent containing an abrasive. Such materials can deteriorate or deform the surface of the cover. Do not apply a lubricant, etc. to any parts inside the machine. Doing so can cause printing failure. Be careful that the cleaning solution, ink, etc. not to stick to the cover because this may cause the surface of the cover to deteriorate or deform.

About Cleaning Solution

Use the cleaning liquid dedicated for the ink being used.

Type of Ink	Applicable maintenance washings
CS ink	Cleaning solution kit 200 (SPC-0369)

Cleaning the Exterior Surfaces

When the exterior surfaces of the machine are stained, dampen a soft cloth with water or a neutral detergent diluted with water, squeeze it, and wipe the surfaces with the cloth.

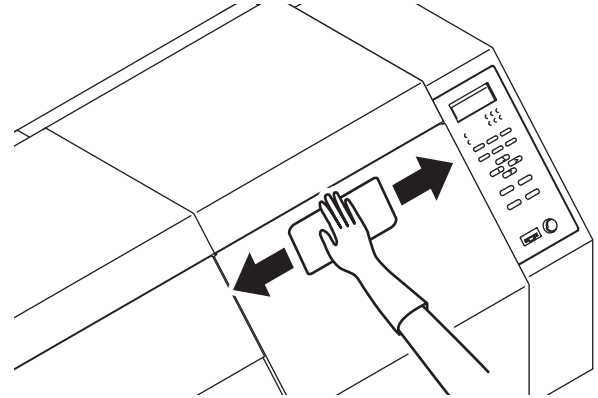

Cleaning the Platen

The platen easily gets dirty with lint, paper dust, etc. generated when a media is cut. Wipe off conspicuous stains with a soft-hair brush, a dry cloth, a paper towel, etc.

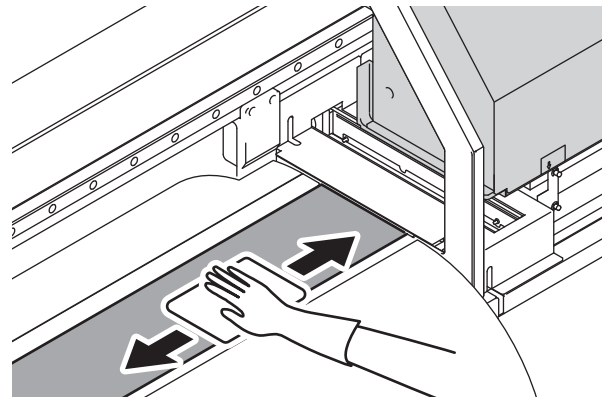

Important!

- Before cleaning the platen, make sure that the platen has cooled adequately.
- Because dust and dirt are easily accumulated in the slots for holding a media and cutting paper (cutter slot), be sure to clean these parts carefully.

Cleaning of after heater cover and pre heater cover

The after heater cover and the pre heater cover are easy to be dirty because of the powder of the medium etc. If it shows dirt, wipe it with a soft cloth soaked in water or waterish mild detergent and wrung.

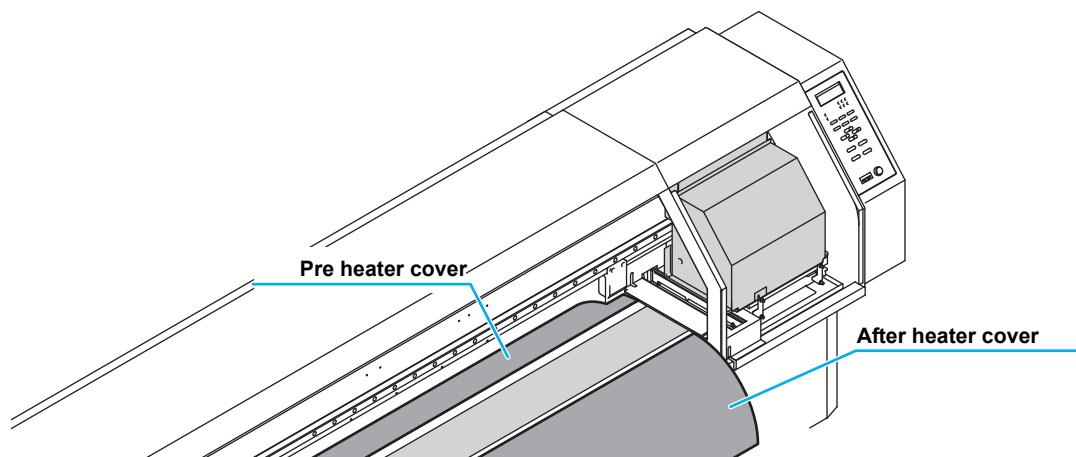

Cleaning the Media Holder

When the media holder is covered with lint, dust, etc., a media cannot be fed normally during printing or dust sticks to the nozzles, which may result in abnormal printing.

Clean the media holder regularly.

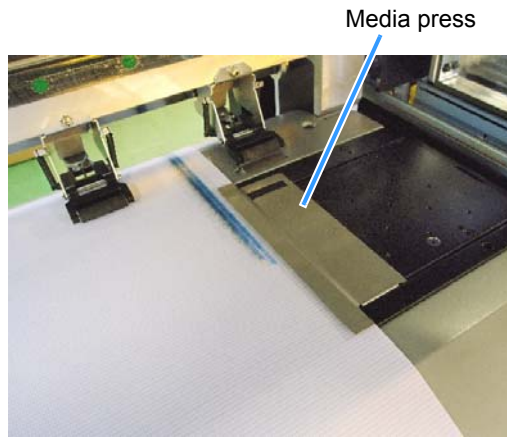

Maintaining the Capping Station

Maintain the ink cap, wiper, etc. located in the capping station. (STATION MAINT.)

The ink cap and wiper function as follows.

- **Wiper** : It wipes off ink sticking to the head nozzles.
- **Ink cap** : It prevents the head nozzles from clogging due to dryness.

As the machine is used repeatedly, the wiper and ink cap gradually become dirty with ink, dust, etc. If nozzle missing cannot be corrected even after head cleaning (☞ P.2-25) has been performed, use a cleaning solution kit and clean stick.

Tools required for Maintenance	• Cleaning solution kit 200 (SPC-0369)		
	• Clean stick (SPC-0527)	• Gloves	• Goggles



- Be sure to wear the supplied goggles and gloves when maintaining the capping station. Otherwise, you may get ink in your eyes.
- Do not move the carriage out of the capping station by hand. When it is desirable to move the carriage, press the **MAINT.** key to execute the carriage-out. (☞ P.4-5 Steps 1 to 2)

Cleaning the Wiper and Cap

It is recommended that the wiper and cap be cleaned frequently in order to maintain the high image quality of the machine and keep the machine itself in good working order.

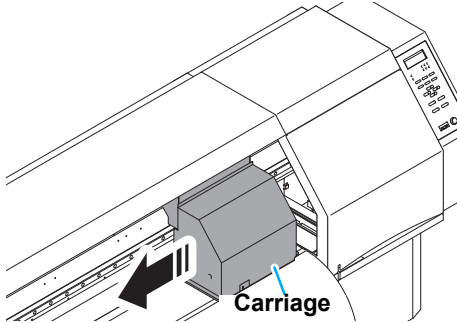

- When CS ink is used, the ink sticks around the wiper easily. Clean the wiper and the area around it about twice a week (it varies, depending on frequency in the use of the machine).
- Replace the wiper with a new one when it is extremely dirty or bent. (☞ P.4-27)
- When cleaning the wiper, be careful that lint from the clean stick does not get left on the wiper. Remaining lint may cause image quality to deteriorate.

1	Press the MAINT. key in LOCAL.	STATION CARRIAGE OUT [ENT]
2	Press the ENTER key.	MOVEMENT PLACE : STATION MAINT.
3	Press ▲ ▼ to select [STATION MAINT.].	MOVEMENT PLACE : STATION MAINT.
4	Press the ENTER key. • The carriage moves to the maintenance position.	

4 Routine Maintenance

5**Open the right maintenance cover cover then remove the wiper.**

- Pull out the wiper by holding the protrusions at its both ends.

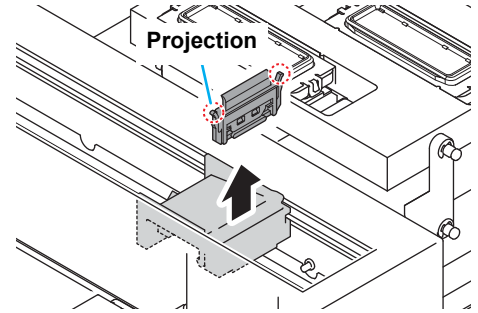
**6****Clean the wiper and bracket.**

- Wipe off the ink sticking to the wiper and bracket with a clean stick dipped in cleaning solution for maintenance. Wipe off so that cleaning solution for maintenance will not remain.

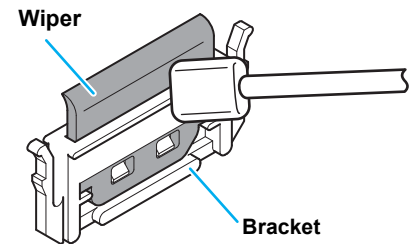
**7****Clean the wiper slider.**

- Wipe off the ink sticking to the wiper slider with a clean stick dipped in cleaning solution for maintenance. Wipe off so that cleaning solution for maintenance will not remain.

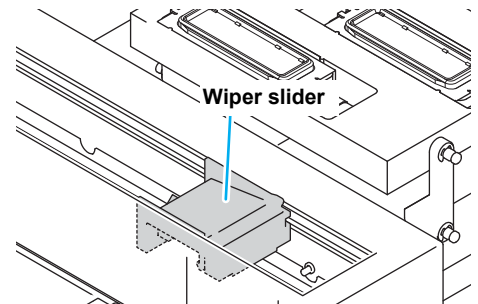
**8****Set the wiper at the original position.**

- Insert the wiper by holding both ends of the wiper.

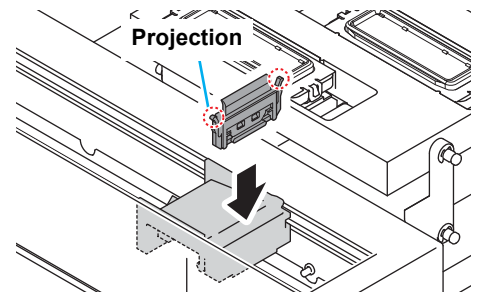
**9****Clean the cap rubber and cap rubber cover.**

- Wipe off the ink sticking to the cap rubber and cap rubber cover with a clean stick dipped in cleaning solution for maintenance. Wipe off so that cleaning solution for maintenance will not remain.

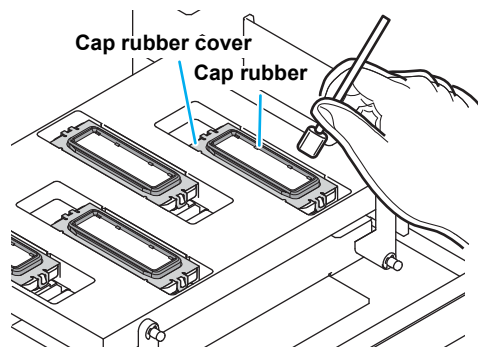

10

Close the right maintenance cover then press the **ENTER** key.

STATION MAINT
PLEASE WAIT

- After its initial operation, the machine returns to step1.

Performing the station maintenance without **MAINT.** key

You can select station maintenance by using the **FUNCTION** key in the Local without pressing the **MAINT.** key.

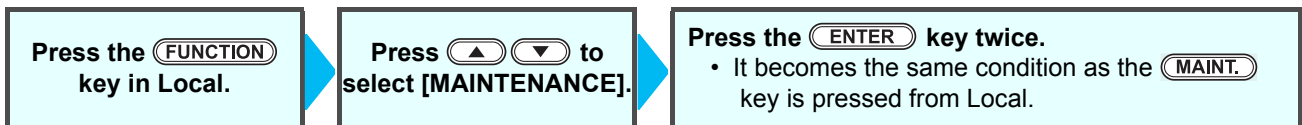

Washing the Ink Discharge Passage (DISWAY WASH)

Wash the ink discharge passage regularly to prevent the head nozzles from clogging due to ink coagulation inside the passage.

1 Press the **MAINT.** key in LOCAL.

STATION
CARRIAGE OUT [ENT]

2 Press **▲** **▼** to select [DISWAY WASH].

STATION
DISWAY WASH [ENT]

3 Press the **ENTER** key.

- The carriage moves to the maintenance position.
- Dry suction operation is performed repeatedly until the washing work is completed.

DISWAY WASH
COMPLETED [ENT]

4 Open the right maintenance cover.

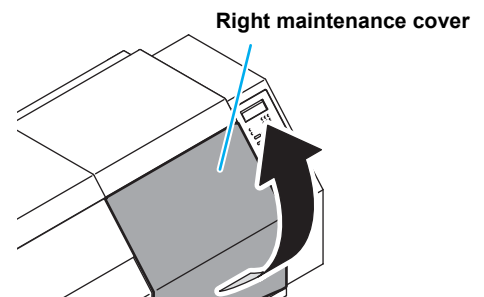

5 Fill up the cap with cleaning solution for maintenance, using a dropper.

- Fill the cap with the cleaning solution just before the solution overflows from the cap.

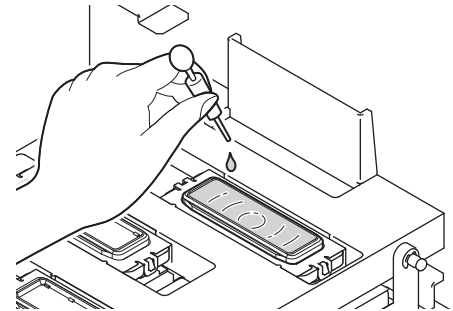

6 Close the right maintenance cover and press the **ENTER** key.

DISWAY WASH
PLEASE WAIT



STATION
DISWAY WASH [ENT]

- After the idle absorbing operation has been performed for 30 seconds, the screen returns to step2.

When the Machine Is Not Used for a Long Time (CUSTODY WASH)

When the machine is not going to be used for a week or more, use the cleaning function for custody to clean the head nozzles and ink discharge passage. After this, keep the machine in custody.

<p>Check the items on the right beforehand.</p>	<p>Is [NEAR END] or [INK END] displayed?</p> <ul style="list-style-type: none"> • The cleaning solution or ink is absorbed when the nozzles are washed. At this time, if the state of "no ink" or "almost no ink" is detected, the nozzle washing operation cannot start. • Replace the ink bottle with another from which the state of "almost no ink" or "no ink" is not detected.
--------------------------------------------------------	---------------------------------------------------------------------------------------------------------------------------------------------------------------------------------------------------------------------------------------------------------------------------------------------------------------------------------------------------------------------------------------------------------------------

- 1

Press the MAINT. key in LOCAL.

STATION
CARRIAGE OUT [ENT]
- 2

Press ▲ ▼ to select [CUSTODY WASH].

STATION
CUSTODY WASH [ENT]
- 3

Press the ENTER key.

 - The carriage moves to the maintenance position.

WIPER CLEANING
COMPLETED [ENT]

Important! • Until wiper/ bracket cleaning is completed, [COMPLETED (NEXT): ENT] is displayed on the screen. After the work up to the step 4 is completed, press the ENTER key. If you press the ENTER key before cleaning is completed, the machine moves to the next washing procedure.

- 4

Clean the wiper and the bracket.

 - (1) Open the right maintenance cover then pull out it by holding projections at both ends of the wiper.
 - (2) Clean the wiper and bracket with a clean stick dipped in cleaning solution for maintenance. (SPC-0369) Wipe off so that cleaning solution for maintenance will not remain.
 - (3) Insert it in the original position by holding the projections at both ends of the wiper.

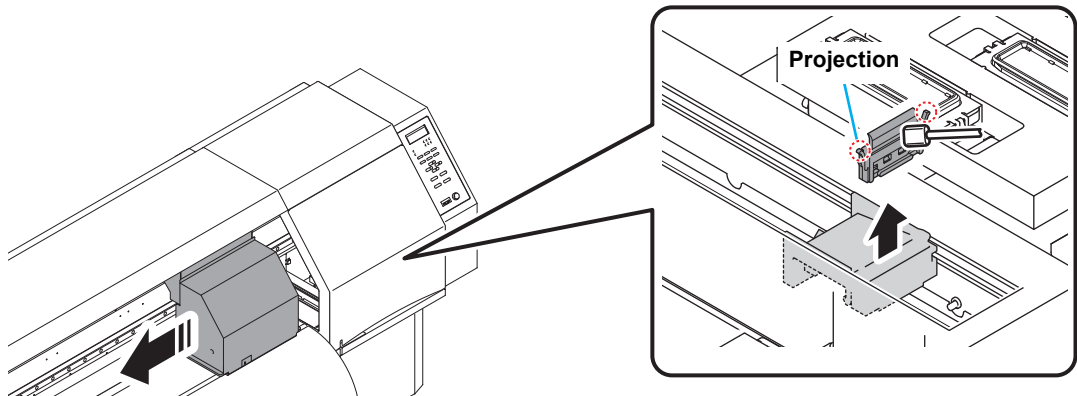

5**Press the **ENTER** key.**

- The carriage moves onto the platen.

CAP CLEANING
COMPLETED (NEXT) [ENT]

Important!

- Until wiper cleaning is completed, [COMPLETED (NEXT): ENT] is displayed on the screen. After the work up to the step 6 is completed, press the **ENTER** key. If you press the **ENTER** key before cleaning is completed, the machine moves to the next washing procedure.

6**Clean the cap rubber and cap rubber cover.**

- Wipe off the ink sticking to the cap rubber and cap rubber cover with a clean stick dipped in cleaning solution for maintenance. Wipe off so that cleaning solution for maintenance will not remain.
- At this time, the discharge passage is cleaned automatically.

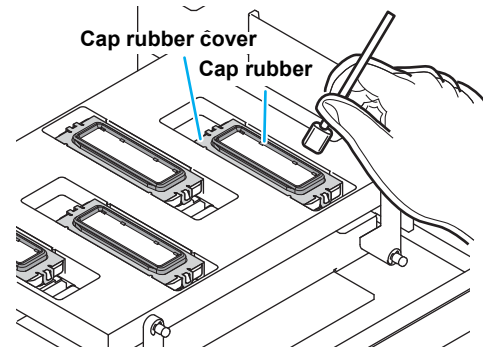
**7****Press the **ENTER** key.**

Fill the liquid
COMPLETED (NEXT) [ENT]

Important!

- Until washing liquid is filled, [COMPLETED (NEXT): ENT] is displayed on the screen. After the work up to the Step 6 is completed and you close the right maintenance cover, press the **ENTER** key. If you press the **ENTER** key before washing liquid is filled, the carriage returns to the original position.

8**Fill up the cap with cleaning solution for maintenance.**

- Take the maintenance washings to a dropper, and fill the cap. Fill the cap with the washings just until the washings overflow from the cap.

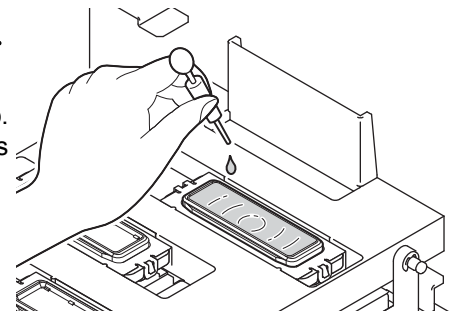
**9****Close the right maintenance cover and press the **ENTER** key.**

LEAVING TIME
= 1 min

10**Press **▲** **▼** to set the time for the cleaning solution to be left as it is.**

LEAVING TIME
= 2 min

- Set Value: 1 to 99 min (by the unit of 1 min)

11 Press the **ENTER** key.

- The nozzles are washed.
- When the nozzles have been completely washed, the head moves to the maintenance position.

DISWAY WASH
COMPLETED [ENT]

12 Open the right maintenance cover.

13 Fill up the cap with cleaning solution for maintenance.

- Take the maintenance washings to a dropper, and fill the cap. Fill the cap with the washings just until the washings overflow from the cap.

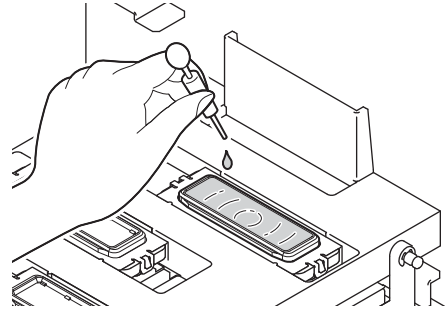

14 Close the right maintenance cover and press the **ENTER** key.

- After its initial operation, the machine returns to step2.

Being Initialized
PLEASE WAIT

Cleaning the Ink Head and the Area around It

Because the ink head employs a very precise mechanism, due care needs to be taken when it is cleaned. Using a clean stick, etc., rub off gelatinous ink or dust that may stick to the lower part of the slider and the area around the ink head. In doing so, never rub the nozzles of the head.

Tools required for cleaning	• Clean stick (SPC-0527)	• Gloves	• Goggles
------------------------------------	--------------------------	----------	-----------



- Be sure to wear the attached goggles and gloves when cleaning the area around the ink head. Otherwise, you may get ink in your eyes.
- The ink contains organic solvent. If you get the ink on your skin or in your eyes, wash it away with plenty of water immediately.

1 Press the **MAINT.** key in LOCAL. STATION
CARRIAGE OUT [ENT]

2 Press the **ENTER** key. MOVEMENT PLACE
: STATION MAINT.

3 Press **▲ ▼** to select [HEAD MAINT.]. MOVEMENT PLACE
: HEAD MAINT.

4 Press the **ENTER** key.
• Carriage will move to the left end of this device.

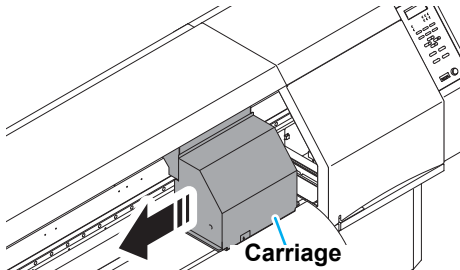

5 Open the left maintenance cover.

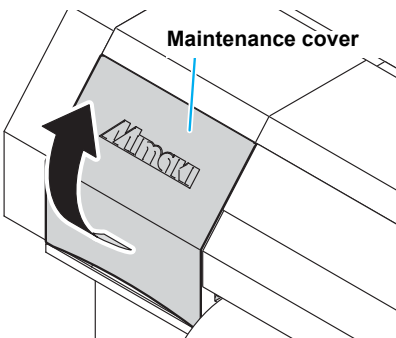

6 Attach the clean stick to the extension bar.

- (1) Insert the clean stick between the holding plates until it hits.
- (2) Fix it with the screw.



7

Wipe ink sticking to the side of the head off with a clean stick.

- (1) Open the left maintenance cover.
- (2) Clean around the head (green position) with a clean stick or waste.

Important! • Do not clean the nozzle surface in this work.

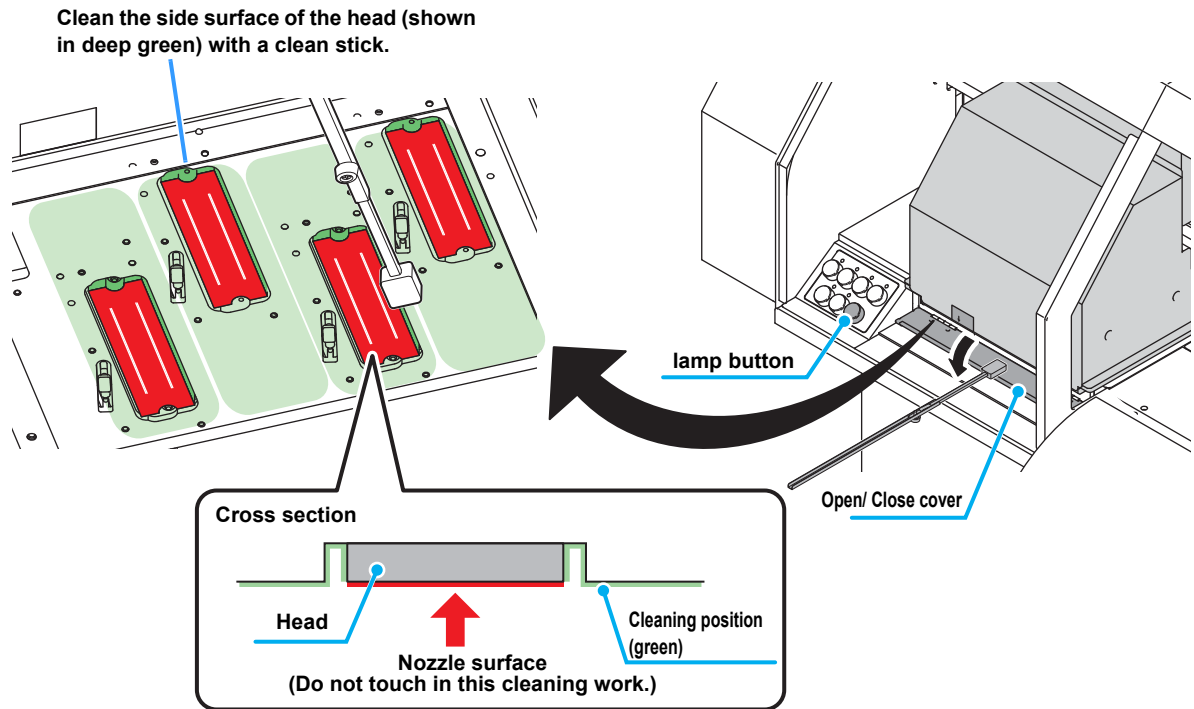

8

Press the **ENTER** key after the cleaning.

STATION MAINT.
COMPLETED [ENT]

- After the initial operation, it returns to the display of Procedure 1.

When Nozzle Clogging Cannot Be Solved

When nozzle clogging cannot be solved even after the ink head cleaning (☞ P.2-25) has been done, perform the following three functions:

INK PURGE	• Eliminates ink clogging by discharging ink from optional ink colors (Heads).
NOZZLE WASH	• If not recover even after ink purge, wash Head nozzle. (☞ P.4-16)
NOZZLE RECOVERY	• Alternative nozzles for printing, when nozzles missing can not be improved. (☞ P.4-18)

Ink purge

Discharge the optional ink to prevent the ink from clogging due to the solidification of ink.

Check the items on the right beforehand.	<p>Is [NEAR END] or [INK END] displayed?</p> <ul style="list-style-type: none"> • Consumes the ink at the ink purge. <p>When the ink bottle becomes empty, it may discharge all ink within the ink routes and the head since the ink is not able to supply to the sub-tank. Replace it with the ink bottle containing sufficient ink.</p>
-------------------------------------------------	---------------------------------------------------------------------------------------------------------------------------------------------------------------------------------------------------------------------------------------------------------------------------------------------------------------------------------------------------------------------

1

Select **[INK PURGE]** of the maintenance menu.

- (1) Press the **[FUNCTION]** key in LOCAL.
- (2) Press **[▲]** **[▼]** to select **[MAINTENANCE]** and press the **[ENTER]** key.
- (3) Press **[▲]** **[▼]** to select **[INK PURGE]**.
- (4) Press the **[ENTER]** key.

INK PURGE [ENT]

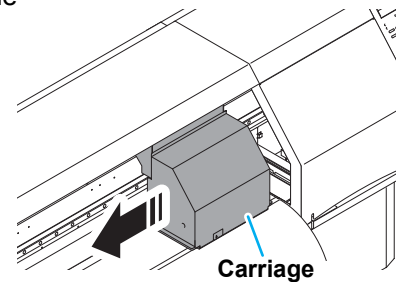

2

Press the **[ENTER]** key.

- The carriage moves to the maintenance position.

Important!

- **[COMPLETED :ENT]** is displayed on the display until the work is completed. Press **[ENTER]** key after the work is completed.

3

Open the left maintenance cover.

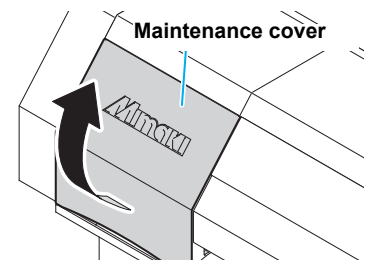

4

Press the purge button and check visually that the ink is discharged normally.

- (1) Open the left maintenance cover.
- (2) Press the button to light the lamp.
 - **The lamp blinks.**
- (3) Press the button of optional ink color and check that the ink is discharged from the head.
 - **The ink is discharged while the button is pressed.**

Important!

- Press the purge button two paths by two (MC or YK).

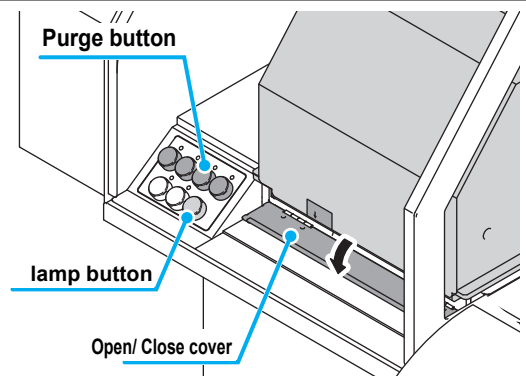

5

Attach the clean stick to the extension bar.

- (1) Insert the clean stick between the holding plates until it hits.
- (2) Fix it with the screw.

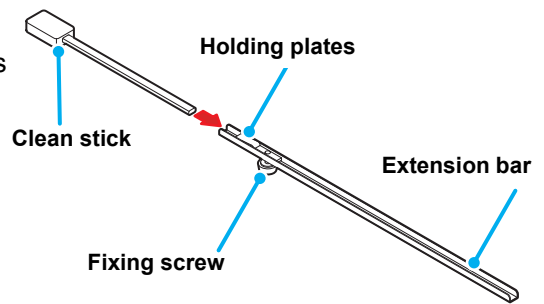

6

Wipe the nozzle surface.

- After ink purge, ink on the nozzle surface is absorbed into the nozzle after a certain time has passed. Wipe the nozzle surface right after ink purge, not taking any time.
- For wipe, use the clean stick (SPC-0527) or the wiper kit for purge (SPA-0202). Use a new clean stick having neither dirt nor dust on it.
- The wiper kit for purge is sold separately.
- Fully clean the wipe part of the wiper kit for purge before using.
- Gently put the flat surface of the sponge part of the clean stick against the nozzle surface rear side, and move the clean stick from the rear to the front taking 2 or 3 seconds to wipe off ink adhering to the nozzle surface.

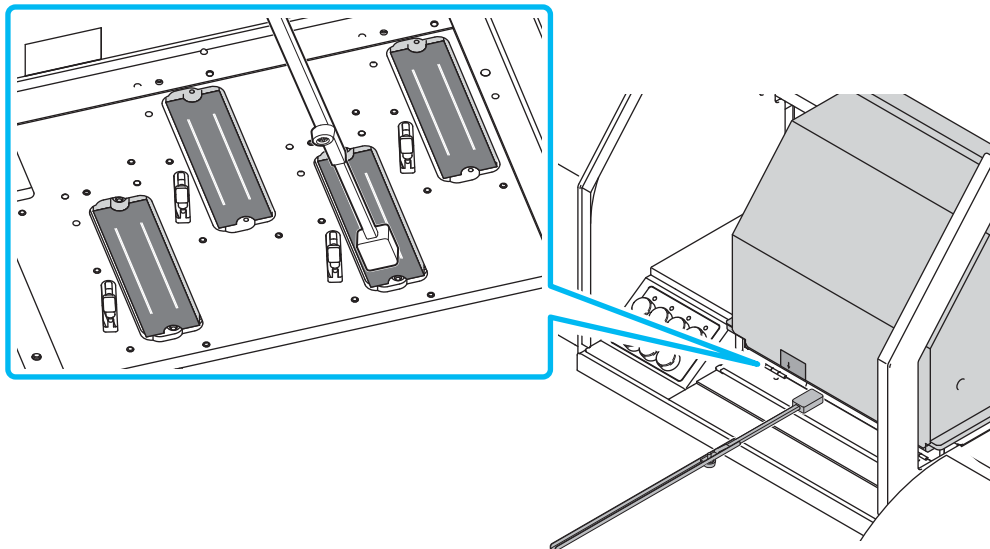

Important!

- Do not rub the nozzle surface strongly.
- Do not use any dirty clean stick.
- If the clean stick absorbed much ink, the wiping ability may be degraded. In such a case, use new one. If you use such a clean stick continuously after squeezing ink of the sponge part, dust adhering to the sponge part etc. may scratch the nozzle surface, or dust may be pushed against the nozzle and it may cause discharge defect.

7

Press the  key.

Washing of Head nozzle

Perform cleaning of the nozzles in the heads to prevent them being clogged with coagulated ink.

Check the items on the right beforehand.

Is [NEAR END] or [INK END] displayed?

- The cleaning solution or ink is absorbed when the nozzles are washed. At this time, if the state of "no ink" or "almost no ink" is detected, the nozzle washing operation cannot start.
- Replace the ink bottle with another from which the state of "almost no ink" or "no ink" is not detected.

1

Press the **MAINT.** key in LOCAL.

STATION
CARRIAGE OUT [ENT]

2

Press **▲** **▼** to select [NOZZLE WASH].

STATION
NOZZLE WASH [ENT]

3

Press the **ENTER** key.

- The carriage moves to the maintenance position.

WIPER CLEANING
COMPLETED (NEXT) [ENT]

Important!

- Until wiper cleaning is completed, [COMPLETED (NEXT): ENT] is displayed on the screen. After the work up to the step 4 is completed, press the **ENTER** key. If you press the **ENTER** key before cleaning is completed, the machine moves to the next washing procedure.

4

Clean the wiper and the bracket.

- (1) Open the right maintenance cover then pull out it by holding projections at both ends of the wiper.
- (2) Clean the wiper and bracket with a clean stick dipped in cleaning solution for maintenance. (SPC-0563) Wipe off so that cleaning solution for maintenance will not remain.
- (3) Insert it in the original position by holding the projections at both ends of the wiper.

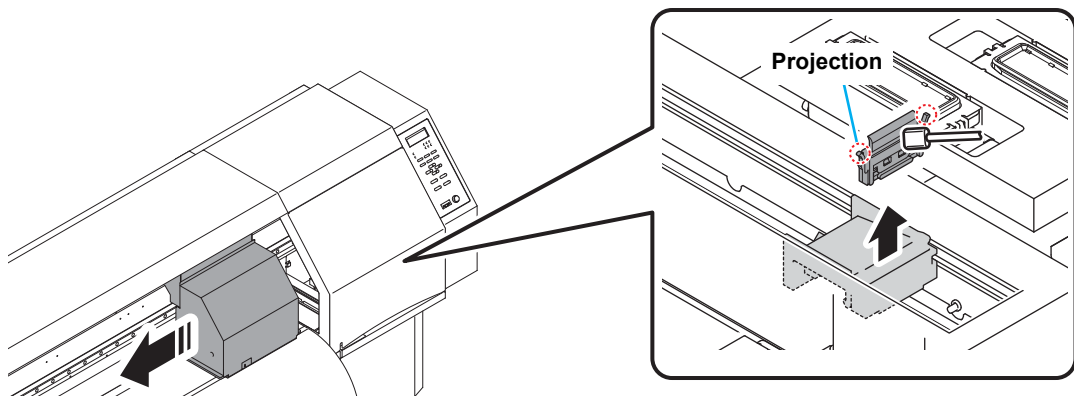

5

Press the **ENTER** key.

- The carriage moves onto the platen.

CAP CLEANING
COMPLETED (NEXT) [ENT]

Important!

- Until wiper cleaning is completed, [COMPLETED (NEXT): ENT] is displayed on the screen. After the work up to the step 6 is completed, press the **ENTER** key. If you press the **ENTER** key before cleaning is completed, the machine moves to the next washing procedure.

6 Clean the cap rubber and cap rubber cover.

- Wipe off the ink sticking to the cap rubber and cap rubber cover with a clean stick dipped in cleaning solution for maintenance. Wipe off so that cleaning solution for maintenance will not remain.
- At this time, the discharge passage is cleaned automatically.

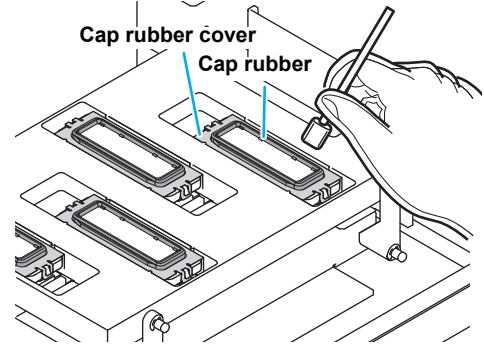

7 Press the **ENTER key.**

Fill the liquid
COMPLETED (NEXT) [ENT]

Important!

- Until washing liquid is filled, [COMPLETED (NEXT): ENT] is displayed on the screen. After the work up to the Step 6 is completed and you close the right maintenance cover, press the **ENTER** key. If you press the **ENTER** key before washing liquid is filled, the carriage returns to the original position.

8 Fill up the cap with cleaning solution for maintenance.

- Take the maintenance washings to a dropper, and fill the cap. Fill the cap with the washings just until the washings overflows from the cap.

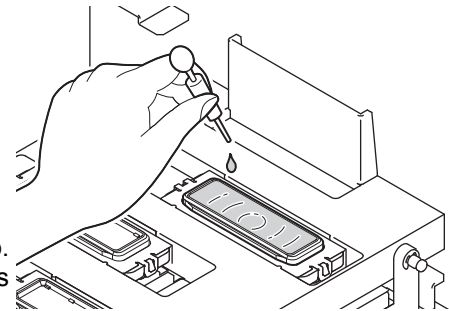

9 Close the right maintenance cover then press the **ENTER key.**

NOZZLE WASHE
LEAVING TIME : 1mi n

10 Press **▲ **▼** to set the time for the cleaning solution to be left as it is.**

- **Set value** : 1 to 99 minutes (Unit: minute)

NOZZLE WASHE
LEAVING TIME : 2mi n

11 Press the **ENTER key.**

- The cleaning solution filled in the cap is absorbed.
- The screen on the right is displayed only for the duration set in the step 9.
- It returns to the step2 after the duration.

NOZZLE WASHE
LEAVING TIME 0 : 36



** CLEAMING **
PLEASE WAIT

Important!

- The ink clogging is not still eliminated even after several ink purges or nozzle washing have been carried out, execute the nozzle recovery. (P.4-18)
- When the image quality is not improved after the nozzle recovery, contact to a dealer or our sales office (service calls).

Alternative nozzles for printing, when nozzles missing can not be improved

NOZZLE RECOVERY: When nozzles missing can not be improved at specific points, other good nozzles can be used as alternatives for printing.

Important!

- Depending on the print mode, the nozzle recovery function becomes invalid. When the nozzle recovery function becomes invalid, you cannot print with an alternative nozzle. Confirm the list of "Valid/ invalid of nozzle recovery function in each print mode", and print with the print mode where the nozzle recovery function is valid.
- In addition, even in the print mode where the nozzle recovery function is valid, recovery may not be reflected depending on the registered nozzle. Check the print condition where the recovery cannot be performed in the check function, and then select the print mode. (☞ P.4-23)

Valid/ invalid of nozzle recovery function in each print mode

Print mode			Nozzle recovery	Print mode			Nozzle recovery
360x600dpi	2pass	Bi / Uni	X	1080x600dpi	2pass	Bi / Uni	X
	4pass	Bi / Uni	O		4pass	Bi / Uni	O
	8pass	Bi / Uni	O		8pass	Bi / Uni	O
540x600dpi	2pass	Bi / Uni	X	1080x600dpi High speed	4pass	Bi / Uni	X
	4pass	Bi / Uni	O		8pass	Bi / Uni	O
	8pass	Bi / Uni	O	1080x900dpi	3pass	Bi / Uni	X
720x600dpi	2pass	Bi / Uni	X		6pass	Bi / Uni	O
	4pass	Bi / Uni	O		12pass	Bi / Uni	O
	8pass	Bi / Uni	O	1080x900dpi High speed	6pass	Bi / Uni	X
720x600dpi High speed	4pass	Bi / Uni	X		12pass	Bi / Uni	O
	720x900dpi	8pass	Bi / Uni	O	1080x1200dpi	4pass	Bi / Uni
3pass		Bi / Uni	X	8pass		Bi / Uni	O
6pass		Bi / Uni	O	16pass		Bi / Uni	O
720x900dpi High speed	12pass	Bi / Uni	O	1080x1200dpi High speed	8pass	Bi / Uni	X
	6pass	Bi / Uni	X		16pass	Bi / Uni	O
	12pass	Bi / Uni	O				

X: Print mode where nozzle recovery function is invalid

O: Print mode where nozzle recovery function is valid

For SWJ-320S2 (2 heads)

1 Select [NOZZLE RECOVERY] of the maintenance menu.

- (1) Press the **FUNCTION** key in LOCAL.
- (2) Press **▲** **▼** to select [MAINTENANCE] and press the **ENTER** key.
- (3) Press **▲** **▼** to select [NOZZLE RECOVERY].
- (4) Press the **ENTER** key.

2 Select the [PRINT] by pressing **▲** **▼** key. Then press **ENTER** key.

- Select t“ENTRY” then “Move to select of the Nozzle line (Step 4) without drawing a pattern”

NOZZLE RECOVERY
: PRINT



NOZZLE RECOVERY
PRINT [ENT]

3 Press the **ENTER** key.

** PRINTING **
PLEASE WAIT

Overhead view

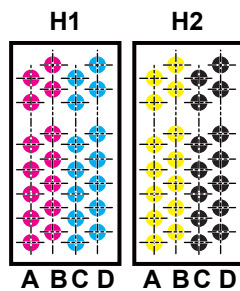

Nozzle line

Nozzle pattern

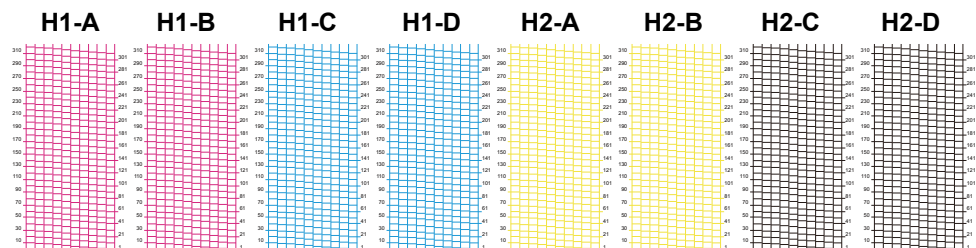

4 Select the Nozzle line that needs NOZZLE RECOVERY by pressing **▲** **▼** key. Then press **ENTER** key.

SELECT NOZZLE
: H1 A

Nozzle line number: A-D

Head No.: H1 to H2

5

Register the Nozzle number that needs NOZZLE RECOVERY and then press **ENTER** key.

- (1) Select the registration number from 1 to 10 by pressing **▲**/**▼** key and press the **ENTER** key.
 - (2) Register the nozzle number that needs recovery by pressing **▲**/**▼** key and press the **ENTER** key.
- Check is performed at the same time of the registration. When there is a mode for which nozzle recover is invalid, the screen of the Step 3 of "Check the print condition for which nozzle recovery cannot be performed".

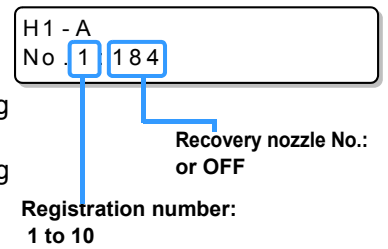

Example of nozzle to be recovered

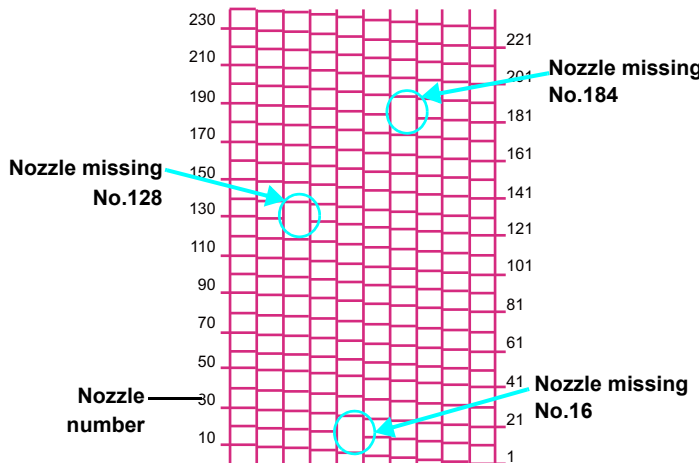

Registration number	Recovery Nozzle No.	State
1	16	Target for nozzle recovery
2	128	Target for nozzle recovery
3	184	Target for nozzle recovery
4	OFF	No registration
5	OFF	No registration

6

Press **END** the key several times to end the setting.

Important!

- Up to 10 nozzles can be registered per 1 nozzle line.
- Even if you use this function, time required for drawing does not change.
- Depending on the print mode, the nozzle recovery function becomes invalid. When the nozzle recovery function becomes invalid, you cannot print with an alternative nozzle. Confirm the list of "Valid/ invalid of nozzle recovery function in each print mode", and print with the print mode where the nozzle recovery function is valid.
- In addition, even in the print mode where the nozzle recovery function is valid, recovery may not be reflected depending on the registered nozzle. Check the print condition where the recovery cannot be performed in the check function, and then select the print mode. (P.4-23)

For SWJ-320S4 (4 heads)

1

Select [NOZZLE RECOVERY] of the maintenance menu.

- (1) Press the **FUNCTION** key in LOCAL.
- (2) Press **▲** **▼** to select [MAINTENANCE] and press the **ENTER** key.
- (3) Press **▲** **▼** to select [NOZZLE RECOVERY].
- (4) Press the **ENTER** key.

2

Select the [PRINT] by pressing **▲** **▼** key. Then press **ENTER** key.

NOZZLE RECOVERY
: PRINT

- Select t“ENTRY” then “Move to select of the Nozzle line (Step 4) without drawing a patern”

3

Select the unit to print by pressing **▲** **▼**, and then press **ENTER** key.

SELECT UNIT
: H1 - 2



NOZZLE RECOVERY
PRINT [ENT]

4

Press the **ENTER** key.

** PRINTING **
PLEASE WAIT

Overhead view

Nozzle pattern

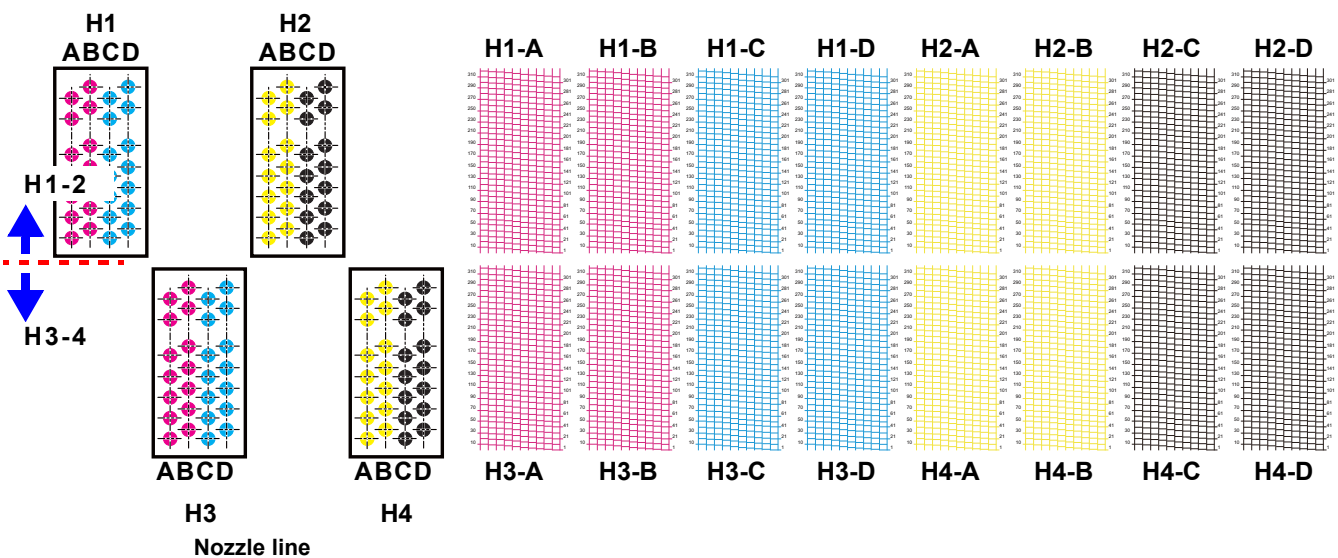

5

Select the Nozzle line that needs NOZZLE RECOVERY by pressing **▲** **▼** key. Then press **ENTER** key.

SELECT NOZZLE
: H1 A

Nozzle line number: A-D

Head No.: H1 ~ H4

6

Register the Nozzle number that needs NOZZLE RECOVERY and then press **ENTER** key.

- (1) Select the registration number from 1 to 10 by pressing **▲**/**▼** key and press the **ENTER** key.
 - (2) Register the nozzle number that needs recovery by pressing **▲**/**▼** key and press the **ENTER** key.
- Check is performed at the same time of the registration. When there is a mode for which nozzle recover is invalid, the screen of the Step 3 of "Check the print condition for which nozzle recovery cannot be performed".

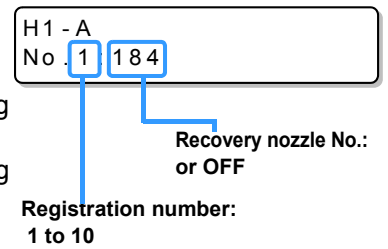

Example of nozzle to be recovered

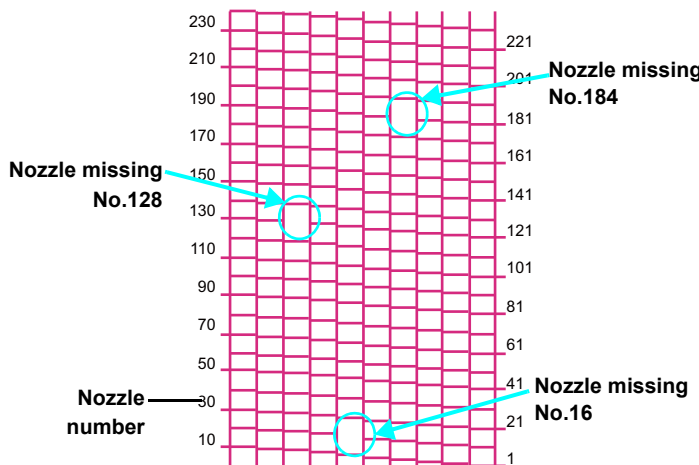

Registration number	Recovery Nozzle No.	State
1	16	Target for nozzle recovery
2	128	Target for nozzle recovery
3	184	Target for nozzle recovery
4	OFF	No registration
5	OFF	No registration

7

Press **END** the key several times to end the setting.

Important!

- Up to 10 nozzles can be registered per 1 nozzle line.
- Even if you use this function, time required for drawing does not change.
- Depending on the print mode, the nozzle recovery function becomes invalid. When the nozzle recovery function becomes invalid, you cannot print with an alternative nozzle. Confirm the list of "Valid/ invalid of nozzle recovery function in each print mode", and print with the print mode where the nozzle recovery function is valid.
- In addition, even in the print mode where the nozzle recovery function is valid, recovery may not be reflected depending on the registered nozzle. Check the print condition where the recovery cannot be performed in the check function, and then select the print mode. (P.4-23)

Check the print condition for which nozzle recovery cannot be performed

Depending on the nozzle registered, there is the mode not reflected by "RECOVERY".
Check the unrecoverable print conditions with the check function.



- If there are many registered nozzles, it takes time to display the check result.

1

Select [NOZZLE RECOVERY] of the maintenance menu.

- (1) Press the **FUNCTION** key in LOCAL.
- (2) Press **▲** **▼** to select [MAINTENANCE] and press the **ENTER** key.
- (3) Press **▲** **▼** to select [NOZZLE RECOVERY].
- (4) Press the **ENTER** key.

2

Select the [CHECK] by pressing **▲** **▼** key.
Then press **ENTER** key.

NOZZLE RECOVERY
: CHECK

3

Press the **ENTER** key.

- The mode for which nozzle recovery is invalid is displayed.
- If there is no mode for which nozzle recovery is invalid, "NONE" is displayed.

IMPOSSIBLE CONDITION
: 720x1200 8p H

Resolution

Number of passes

Scanning speed

4

Press **END** the key several times to end the setting.

Clear the set value

1 Select [NOZZLE RECOVERY] of the maintenance menu.

- (1) Press the **FUNCTION** key in LOCAL.
- (2) Press **▲** **▼** to select [MAINTENANCE] and press the **ENTER** key.
- (3) Press **▲** **▼** to select [NOZZLE RECOVERY].
- (4) Press the **ENTER** key.

2 Select the [RESET] by pressing **▲** **▼** key. Then press **ENTER** key.

```
NOZZLE RECOVERY
: RESET
```

3 Press the **ENTER** key.

```
SELECT RESET NOZZLE
: H1 - A
```

4 Select the Nozzle line that needs clear the setting value by pressing **▲** **▼** key. Then press **ENTER** key.

```
SELECT RESET NOZZLE
: H1 - A
```



```
H1 - A RESET?
EXECUTE [ENT]
```

5 Press the **ENTER** key.

6 Press **END** the key several times to end the setting.

Automatic Maintenance Function

To use this machine comfortably, you can set various maintenances to be performed automatically. Here, set performing intervals of various automatic maintenances. You can prevent troubles such as ink clogging by performing automatic maintenance periodically (automatic maintenance function).

For the auto maintenance functions, the following items can be set:

- Important!** • When you perform maintenance manually, after manual maintenance is completed and when time set with the automatic maintenance function has passed, maintenance starts automatically.

Function name	Descriptions
REFRESH	The interval between each refreshing operation is set.
PUMP TUBE WASH	The interval between each PUMP tube washing operation is set.
CLEANING	The interval between each cleaning operation is set.

- Important!** • During the right message is displayed, the operation set in the auto maintenance function is not carried out. Perform the operations of P.4-28 if required.
- When the power switch on the front of the machine is turned off, check the waste ink tank.

```
<LOCAL>
Check waste ink [MNT]
```

Setting the Refreshing Intervals

The interval between each operation of ejecting a small amount of ink from the nozzles to prevent nozzle clogging is set.

1 Select [AUTO MAINT.] of the maintenance menu.

- (1) Press the **FUNCTION** key in LOCAL.
- (2) Press **▲** **▼** to select [MAINTENANCE] and press the **ENTER** key.
- (3) Press **▲** **▼** to select [AUTO MAINT.].

2 Press the **ENTER** key.

```
AUTO MAINT .
REFRESH           [ ENT ]
```

3 Press the **ENTER** key.

```
REFRESH
: Lv . 1
```

4 Press **▲** **▼** to set the refreshing interval.

- Set value : Lv.1, Lv.2, Lv.3
- As the LEVEL increases, the interval between each operation gets shorter.

```
REFRESH .
: Lv . 1
```

5 Press the **ENTER** key.

```
AUTO MAINT .
REFRESH           [ ENT ]
```

6 Press **END** the key several times to end the setting.

Setting the Cleaning Intervals

The cleaning type and the interval between each cleaning operation are set.

- 1** Select [AUTO MAINT.] of the maintenance menu.

(1) Press the **FUNCTION** key in LOCAL.
 (2) Press **▲** **▼** to select [MAINTENANCE] and press the **ENTER** key.
 (3) Press **▲** **▼** to select [AUTO MAINT.].
 (4) Press the **ENTER** key.

- 2** Press **▲** **▼** to select [CLEANING].

AUTO MAINT .
 CLEANING [ENT]

- 3** Press the **ENTER** key.

CLEANING
 : Lv . 1

- 4** Press **▲** **▼** to set the interval between each cleaning operation.

CLEANING
 : Lv . 1

 - Set value : Lv.1, Lv.2, Lv.3
 - As the LEVEL increases, the interval between each operation gets shorter.

- 5** Press the **ENTER** key.

 - The cleaning type selection screen appears.

TYPE
 : NORMAL

- 6** Press **▲** **▼** to select a cleaning type.

 - Set value : NORMAL, SOFT, HARD

TYPE
 : SOFT

- 7** Press the **ENTER** key.

AUTO MAINT .
 CLEANING [ENT]

- 8** Press the **END** key several times to end the setting.

Replacing consumables

Replacing the wiper

The wiper is consumable. When the display indicates that it is necessary to replace the wiper, immediately replace the wiper with a new one. Also, wipe ink sticking to the lower surface of the slider off.

<LOCAL>
!Replace Wiper [MNT]

Important!

- A cleaning wiper is an option. Buy one through the dealer in your region or at our service office.

1

Press the **MAINT.** key in LOCAL.

REPLACE WIPER
EXECUTE [ENT]

2

Press the **ENTER** key.

- The carriage moves to the maintenance position.

REPLACE WIPER
COMPLETED [ENT]

Important!

- Until the replacement work is completed, [COMPLETED: ent] is displayed on the screen. After the work up to the Step 5 is completed and you close the front cover, press the **ENTER** key.

3

Open the right maintenance cover then remove the wiper.

- Pull out the wiper by holding the protrusions at its both ends.

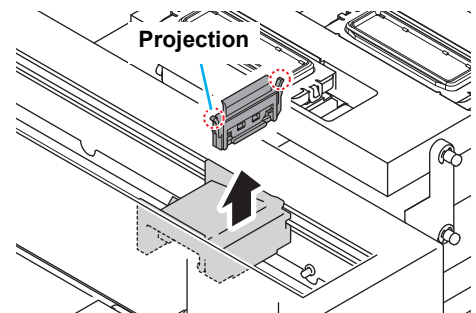

4

Insert a new wiper.

- Insert a new wiper by holding its both ends.

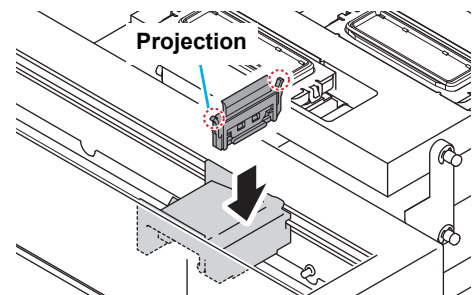

5

Close the right maintenance cover then press the **ENTER** key.

- After its initial operation, the machine returns to LOCAL.

Being Initialized
PLEASE WAIT

4

Routine Maintenance

Replace the waste ink tank with another

On this unit, two waste ink tanks are used left and right.
Replace it as early as possible so that the waste ink does not overflow from each tank.

1

Pull out the tubes of waste ink tank.

- Take care not to dirty the surrounding by ink drips.

2

Put the tubes into a new waste ink tank.

- Wear a cap to the waste ink tank containing the waste ink.



- Waste ink is equivalent to waste oil of industrial waste. Request an industrial waste disposal company for disposal of waste ink.

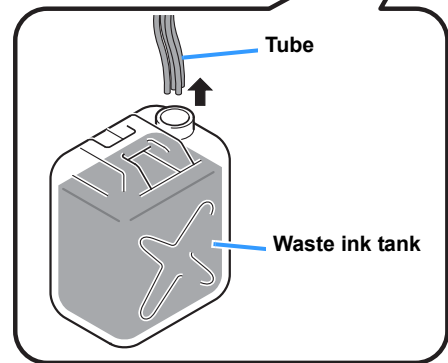

Replacing the fan filter

When the fan filter is stained with ink, replace it.

Rough standard for replacing filter: Per printing about 2,000m² (12 roll media of width 3.2m x length 50m)

Important!

- Fan filters are option. Buy one through the dealer in your region or at our service office.
Fan filter (SPA-0201) 10 pcs

1

Confirm whether the carriage is stand by, and turn off the main power switch.

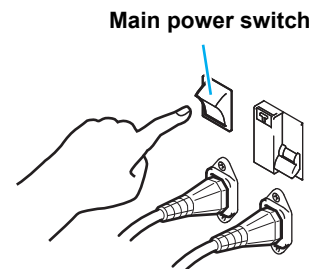

2

Open the right maintenance cover and the front cover.

3

Loosen a screw by turning two or three turns, and remove filter holder plate 1•2 and fan filter together.

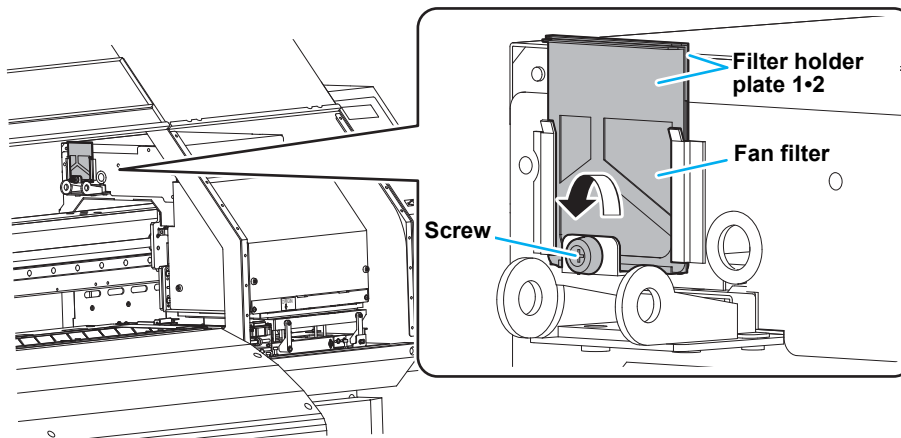

4

Move the filter holder plate 1 a little bit, and replace the fan filter with new one.

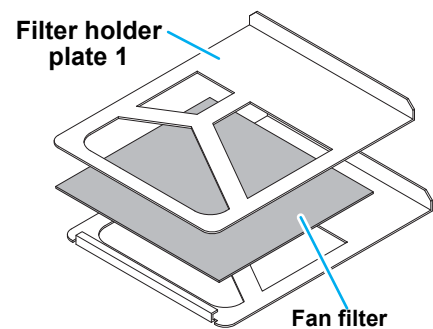

4

Routine Maintenance

5

Pile up in order of the filter holder plate 2, the fan filter, and the filter holder plate 1.

Important!

- Check whether the fan filter is attached to the filter holder plate 1•2 without any space.

Filter holder plate 1

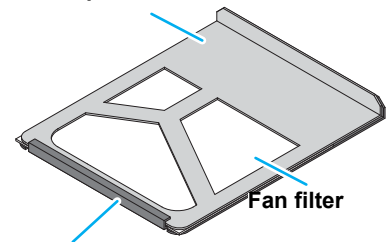

Filter holder plate 2

6

Attach the fan filter set in the step4 to the original place, and tighten the screw.

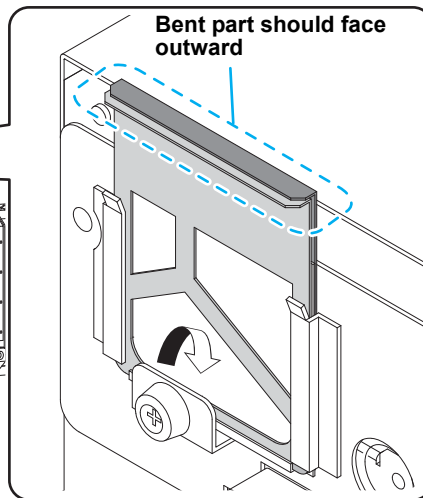
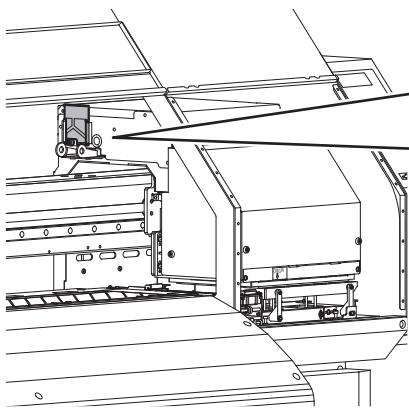

Important!

- Make sure to attach it so that bent part of the filter holder plate faces outward.

7

Close the right maintenance cover and the front cover.

Chapter 5

Troubleshooting



This chapter

describes the corrective measures to be taken for a phenomenon suspected to be trouble and the procedures to clear the error number displayed on the LCD.

Troubleshooting	5-2
Power does not turn on	5-2
The machine does not start printing	5-2
Media get jammed / media is soiled	5-3
Image quality is poor	5-3
Nozzle is clogged	5-4
When media heaves up at feeding	5-4
Warning / Error Messages	5-5
Warning messages	5-5
Error messages	5-8

Troubleshooting

Take appropriate actions as described below before taking the trouble as a failure.
If still the problem is not solved after troubleshooting, contact your dealer or an office of MIMAKI.

Power does not turn on

In most cases, this is due to improper connection of the power cable for the machine or computer. Check that the power cable is connected properly.

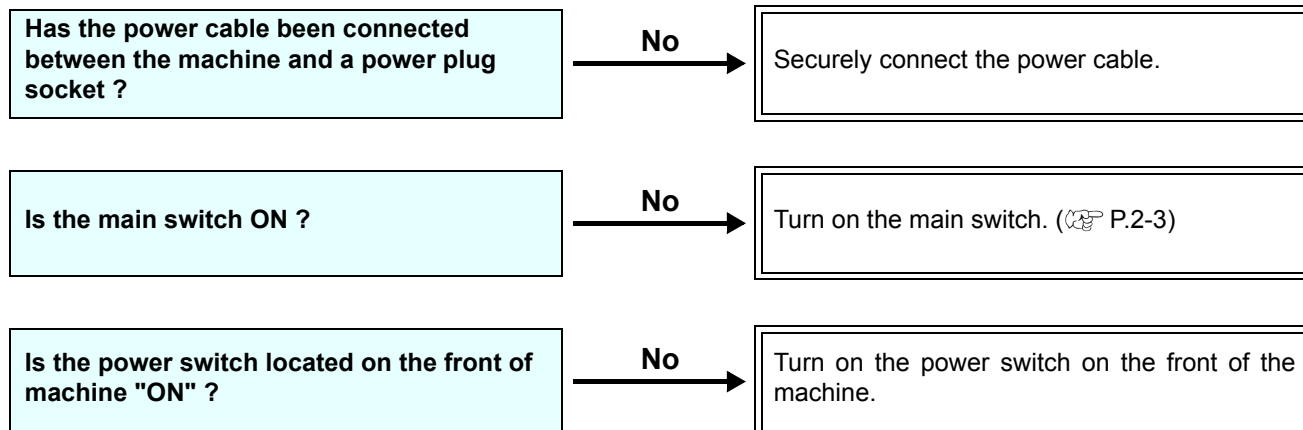

The machine does not start printing

This occurs when the data is not being transmitted to the machine properly.
It can also occur when the printing function does not work properly or the media is not set correctly.

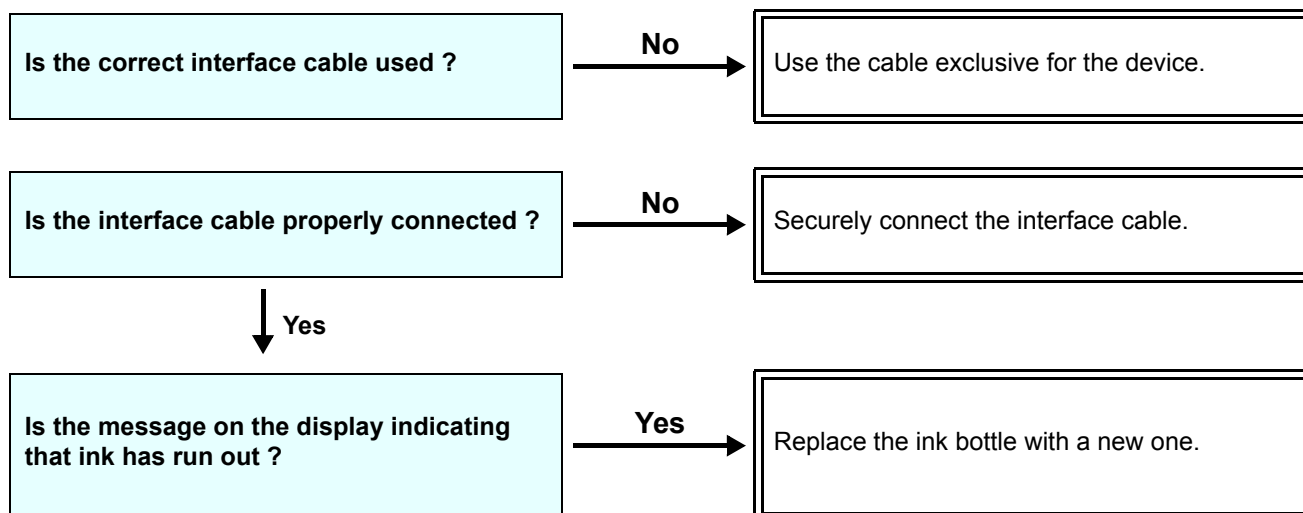

Media get jammed / media is soiled

Media jamming or stained media is considered to be due to the use of an unsuitable media or improper setting of media.

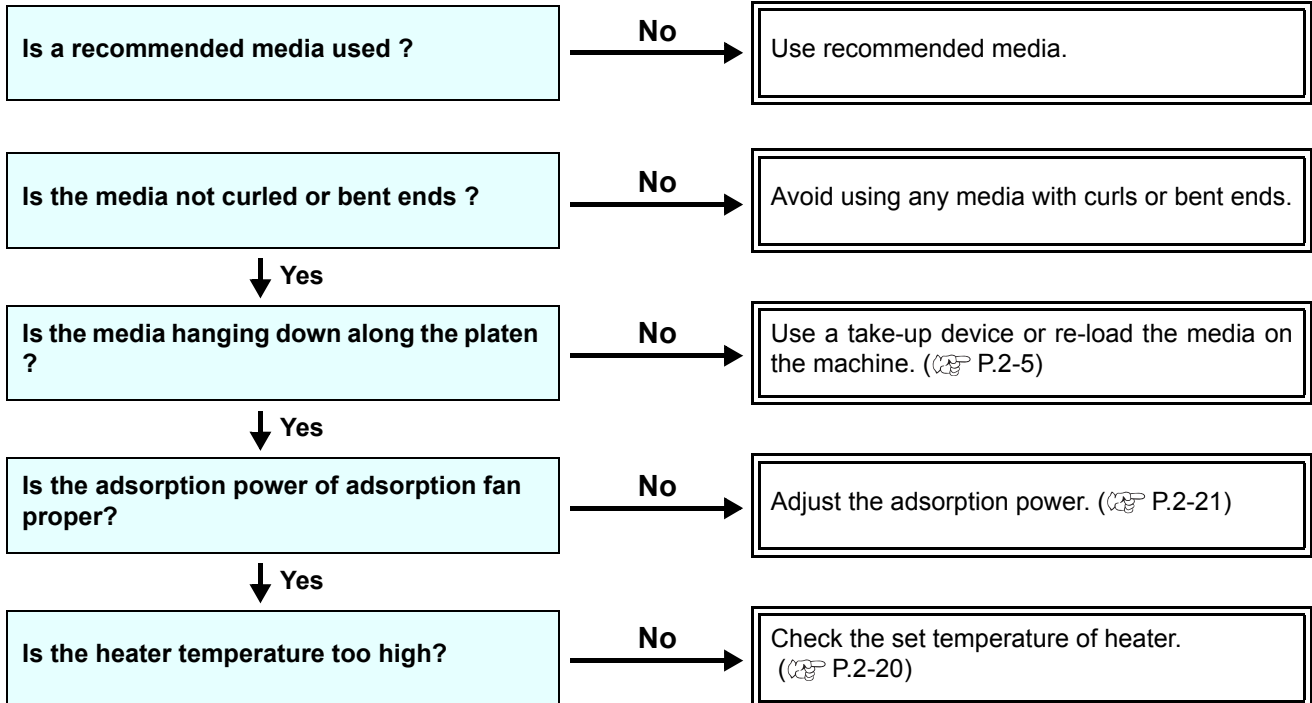

Image quality is poor

This section describes the corrective actions to be taken in case the image quality is not satisfactory. Take remedy for particular problems with image quality. If the remedy does not work, contact your dealer or an office of MIMAKI.

Phenomenon	Measures
White lines / blur / dark stripes (in the direction of travel of the heads)	(1) Execute the head cleaning. (☞ P.2-25) (2) Perform maintenance of the inside of the station. (☞ P.4-5) (3) Execute the [MEDIA COMP.] function. (☞ P.2-26) (4) Slow down the scanning speed. (☞ P.3-9) (5) If any pieces of paper or dust is attached on the path of the heads such as media press, remove it.
Characters are double- or triple-printed in the media feed direction	(1) Execute the [MEDIA COMP.] function. (☞ P.2-26)
Disagreement in print positions between outward trip and homeward trip	(1) Execute the [DROP POSITION] function. (☞ P.2-32)
Ink drops falling on media during printing	(1) Execute the wiper cleaning. (☞ P.4-5) (2) Execute the ink cap cleaning. (☞ P.4-5) (3) Clean around the head. (☞ P.4-12) (4) Execute the head cleaning [NORMAL]. (☞ P.2-25)



Nozzle is clogged

When nozzle clogging is not dissolved even after the head cleaning referring to P.2-25, make sure the following operations.

- Carry out the ink purge. of P.4-14.
- Wash the head nozzle by the operations of P.4-16.
- Recovery the nozzle by the operations of P.4-18.

When media heaves up at feeding

We call the status of heaving media at feeding “cockling”.
When media cockling occurs, check the following items:

Note/ checking items	Measures
Checking media set status	(1) Check that the media is set straight and reset it.
Adjusting heater temperature	(1) Raise the pre-heater temperature by 5 to 10 degrees. (2) Lower all heaters' temperatures. (When you lower the heater temperature, drying time may not be enough. Lower the FEED SPEED.)
Media feeding	(1) For roll media, feed the media by about tens of centimeters to one meter. (2) For leaf media, press   and perform feed/ back feed.
Do not leave the media in the heater warming status	(1) Do not start printing with the media cockled because it may cause media jam.
Heighten the head	(1) For the thicker media, raise the head height at printing.

Warning / Error Messages

If some trouble occurs, the buzzer sounds and the display shows a corresponding error message. Take an appropriate remedy for the displayed error.

Warning messages

Errors when performing operations

Message	Cause	Solution
INVALID OPERATION MEDIA UNDETECTED	The media has not been detected.	Perform media detection.
INVALID OPERATION INK ERROR	An ink error occurred.	Check the ink-bottle for the supply path corresponding to the indicated color.
INVALID OPERATION DATA REMAIN	Data was received.	Perform data clear. (☞ P.2-35)
INVALID OPERATION PRINT AREA SHORT	As the printing area is not enough, printing cannot be performed.	Set new media. (☞ P.2-5)
Under Suspension Reset a Switch	The stop switch is being pressed.	Cancel the stop switch.

Message displayed in LOCAL

Message	Cause	Solution
<LOCAL> Replace a WIPER[MNT]	Time to replace the wiper in the capping station with a new one has come. (The wiping count has reached the specified value.)	Press the MAINT. key and replace the wiper with a new one. (☞ P.4-27)
<LOCAL> DATA REMAIN	Data has been received.	Execute the printing by pressing REMOTE key. Or, execute the data clearing.
<LOCAL> INK NEAR END MCYK	The ink of ink bottle became less.	Note that the ink end will be soon.
<LOCAL> EXPIRATION MCYK	Ink in current use expired.	Prepare new ink bottle.
<LOCAL> EXPIRATION(1M) MCYK		
<LOCAL> EXPIRATION _n (2M) MCYK	Ink in current use expired.	Replace it with new ink bottle.
CHARGE INK END<MCYK> PLEASE INSERT INK IC	The charged ink became none.	Perform ink charge. (☞ P.1-11)
CheckInkBottle :MCYK COMPLETED [ENT]	The ink could not be supplied to the sub-tank.	Check the ink bottle. If the inkbottle is empty, replace it with a new one, and press key. If the same error message appears again, contact your local distributor to call for service.
<LOCAL> ** NO MEDIA **	There became no media.	Replace it with new one.
<LOCAL> TANKlevelIH :MCYK	Ink consumption status inside the sub tank is abnormal. (There is a possibility of discharging defect.)	<ul style="list-style-type: none"> Perform "CLEANING(HARD)" or "INK PURGE". (☞ P.2-25) (☞ P.4-14) If the message is displayed repeatedly even if you performed above many times, contact your local distributor to call for service.

Ink Error

Ink error is displayed also in the local guidance. (☞ P.3-23)

Message	Cause	Solution
INK EXPIRATION CHARGE ANYWAY?	You tried to charge ink that has been expired.	<ul style="list-style-type: none"> • Replace it with new ink bottle. • If you use as it is, select [YES].
INK EXPIRATION (1M) CHARGE ANYWAY?		
INK EXPIRATION (2M) CANNOT CHARGE	You try to use ink that has been expired.	<ul style="list-style-type: none"> • Replace it with new ink bottle.
WRONG INK IC CANNOT CHARGE	The ink IC chip cannot be read normally.	<ul style="list-style-type: none"> • Reinsert the IC chip. • If the same error message appears again, contact your local distributor to call for service.
INK IC ALREADY USED CANNOT CHARGE	The ink IC chip that has already been used was set.	<ul style="list-style-type: none"> • Check that the IC chip is the one attached to the ink bottle.
INK TYPE CANNOT CHARGE	The ink IC chip whose ink type is different from that of the filled ink was set.	<ul style="list-style-type: none"> • Check that the IC chip is the one attached to the ink bottle. • Check the ink type of the ink bottle.
INK COLOR CANNOT CHARGE	The ink IC chip whose ink color is different from that of the filled ink was set.	<ul style="list-style-type: none"> • Check that the IC chip is the one attached to the ink bottle. • Check the ink color of the ink bottle.
INK LEVEL REMAINS CANNOT CHARGE	The charged ink remains more than half, and ink charge cannot be performed.	<ul style="list-style-type: none"> • Check that the IC chip is the one attached to the ink bottle. • Check the ink color of the ink bottle.
INK LEVEL REMAINS CHARGE ANYWAY?	You tried to perform ink charge while the charged ink remains.	<ul style="list-style-type: none"> • Check that the IC chip is the one attached to the ink bottle. • Check the ink color of the ink bottle. • If you use as it is, select [YES].
NON INK IC CANNOT CHARGE	The ink IC chip was pulled out during charge.	<ul style="list-style-type: none"> • Reinsert the IC chip, and perform ink charge again. • Do not pull out the IC chip during charge. • If the warning is displayed again even if you did not pull out the IC chip, contact a distributor in your district or our office to call for service.
INK EXPIRATION MCK	Ink in current use expired.	<ul style="list-style-type: none"> • Prepare new ink bottle.
INK EXPIRATION (1M) MCK		
INK EXPIRATION (2M) MCK	Ink in current use expired.	<ul style="list-style-type: none"> • Replace it with new ink bottle.
INK NEAR END MCK	Ink in the ink bottle became less.	<ul style="list-style-type: none"> • Check the remaining amount of the ink bottle. • When Ink charge is displayed, perform ink charge.

Error messages

When an error message is displayed, eliminate the error according to the chart below.
If the same error message appears again, contact your dealer or an office of MIMAKI to call for service.

Message	Cause	Solution
ERROR 108 HD CONNECT [1 2 3 4 5 6 7 8]	Head connection can not be confirmed.	Turn off the power to the machine and turn it on after a while. If the same error message appears again, contact your local distributor to call for service.
ERROR 108 HD THERMIS [1 2 3 4 5 6 7 8]	Head temperature can not be read.	
ERROR 12e Head Failed [x x x x]	Abnormality of the Driver of the Print head.	
ERROR 122 CHECK : SDRAM	There is no PRAM.	
ERROR 128 HDC FIFO OVER	<ul style="list-style-type: none"> • Data transmission speed is too fast. • Control circuit board is defective. 	
ERROR 128 HDC FIFO UNDER	<ul style="list-style-type: none"> • Data transmission speed is too slow. • Control circuit board is defective. 	
ERROR 129 BATTERY EXCHANGE	The battery life end of the internal clock is detected.	Contact your local distributor to call for service.
ERROR 130 HD DATA SEQ	Head data transferring sequence error occurred.	Turn off the power to the machine and turn it on after a while. If the same error message appears again, contact your local distributor to call for service.
ERROR 146 E-LOG SEQ	Sequential number abnormality of the event log occurred.	
ERROR 151 Main PCB V12R	An error occurred in the main PCB 1.2V power supply.	
ERROR 152 Main PCB V2R5	An error occurred in the main PCB 2.5V power supply.	
ERROR 153 Main PCB V3R3	An error occurred in the main PCB 3.3V power supply.	
ERROR 154 Main PCB V05	An error occurred in the main PCB 5V power supply.	
ERROR 155 Main PCB V35-1	An error occurred in the main PCB 35-1 power supply.	
ERROR 156 Main PCB V5B	An error occurred in the main PCB 5VB power supply.	
ERROR 157 Main PCB VTT	An error occurred in the main PCB VTT power supply.	
ERROR 158 Main PCB V352	An error occurred in the main PCB 35-2V power supply.	

Message	Cause	Solution
ERROR 158 Main PCB V3R3B	An error occurred in the main PCB 3.3VB power supply.	Turn off the power to the machine and turn it on after a while. If the same error message appears again, contact your local distributor to call for service.
ERROR15f HEAD DRIVE HOT	COM driver becomes the high temperature.	
ERROR 171 NEW HEAD CONNECT	New Print Head was recognized.	
ERROR 172 Main PCB Q6 Check K	The main PCB Q6 is disabled (short mode).	
ERROR 186 HDC OVERFLOW	An error is detected on the waveform printed on.	
ERROR 186 HDC UNDERFLOW		
ERROR 187 HDC SLEW RATE		
ERROR 188 HDC MEMORY		
ERROR 201 COMMAND	The machine received some data other than command data.	Securely connect the interface cable in position. Use an interface cable conforming to the specifications.
ERROR 202 PARAMETER	Any parameter outside the range of acceptable numeric values was received.	
ERROR 203 Ment Command	A maintenance command error occurred.	
ERROR 304 USB INIT ERR	USB device initialization failure.	Turn off the main power to the machine and turn it on after a while. If the same error message appears again, contact your local distributor to call for service.
ERROR 305 USB TIME OUT	Occurrence of a time out error on a USB device.	
ERROR 401 MOTOR X	An excessive load was applied to the X motor.	
ERROR 402 MOTOR Y	An excessive load was applied to the Y motor.	
ERROR 403 X CURRENT	An error due to an excessive current of the X motor was detected.	
ERROR 404 Y CURRENT	An error due to an excessive current of the Y motor was detected.	

Message	Cause	Solution
ERROR 509 HDC POSCNT	A HDC position counter error occurred.	
ERROR 50a Y ORIGIN	Y-origin could not be detected.	Turn off the main power to the machine and turn it on after a while. If the same error message appears again, contact your local distributor to call for service.
ERROR 50f L-SCALE BLACK	Abnormal linear scale.	
ERROR 510 X ORIGIN	The X origin could not be detected.	
ERROR 516 MEDIA SET POSITION R	The media is set outside the proper area.	Check the media set position. (☞ P.2-5)
ERROR 902 DATA REMAIN	There remains received data that has not yet been printed.	Execute the data clear function. (☞ P.2-35)
ERROR 90d NO HEAD SELECT	The number of mounted heads indicates 0.	Turn off the main power to the machine and turn it on after a while. If the same error message appears again, contact your local distributor to call for service.
ERROR 910 ENVIRONMENT TEMP (LO)	The ambient temperature is out of the usable temperature range (too low).	Adjust the ambient temperature of the installation place.
ERROR 911 ENVIRONMENT TEMP (HI)	The ambient temperature is out of the usable temperature range (too high).	

SYSTEM HALT

Message	Solution
SYSTEM HALT 000: MESSAGE	Turn off the main power to the machine and turn it on after a while. Check the number and contact your local distributor to call for service. ("000" is the error No.)

Chapter 6

Appendix



This chapter

contains the lists of the specifications and functions of this machine.

Specifications	6-2
Machine specifications	6-2
Ink specifications	6-3
Warning labels	6-4
Sheet for inquiry	6-6
Function Flowchart	6-8

Specifications

Machine specifications

Item		SWJ-320S2	SWJ-320S4
Print head	Method	Drop-on-demand piezoelectric print heads	
	Specification	2 head	4 head
Drawing mode (scan x feed)		360 x 600, 540 x 600, 720 x 600, 720 x 900, 1080 x 600, 1080 x 900, 1080 x 1200	
Usable inks		CS ink	
		Y,M,C,K	
Ink supply		Supplying from ink bottles through tubes. Ink bottle replacement type	
Capacity of ink bottle		2,000ml	
Media type		PVC/ Tarpaulin/ FF	
Max. printing width		Y360dpi: 3200 mm Y720dpi: 3200mm Y1080dpi: 3000mm	
Roll Media size	Maximum	3250 mm	
	Minimum	1300 mm	
	Thickness	1 mm or less	
	Roll inside diameter	3 inches	
	Printing surface	Roll inside/out side Both possible	
	Roll end treatment	The roll end is gently fixed to the core with weak-adhesive tape or weak glue for easy removal.	
	Feeding device	Maximum outline: Φ 220 mm Maximum outline when using narrow roll feeding: Φ 180	
		Maximum weight: 100 kg Maximum weight when using narrow roll feeding: 25kg	
Take-up device	Maximum outline: Φ 120 mm		
	Maximum weight: 40 kg		
Leaf media size	Maximum	3250 mm	
	Minimum	210 mm	
Distance accuracy	Absolute accuracy	Whichever the larger one of ± 1.5 mm or ± 0.3 % of the designated	
	Reproducibility		
Perpendicularity		± 2.5 mm / 1000 mm	
Media skew		5 mm or less / 10000mm	
Head height adjustment		Stepless adjustment 2 ~ 4 mm	
Cutting of media		Cutting by hand.	
Media delivery		Take-up device supplied as a standard accessory (switching possible between face in and face out).	
Waste ink tank		Bottle type (10L): 2 pcs. (1 per the left side purge area and 1 at the suction pump part of the right side)	
Interface		USB 2.0	
Command		MRL- III	
Power		AC200 - 240 \pm 10%, 50/60Hz \pm 1Hz, INLET1: 5A or less INLET2: 10A or less INLET3: 14A or less	
Power consumption		INLET1: 1200VA or less INLET2: 2400VA or less INLET3: 3360VA or less	
Reco- mended Environ- ment	Available temp.	20 °C to 30 °C	
	Humidity	35 to 65% Rh (No condensation)	
	Guaranteed temp.	20 °C to 25 °C	
	Temperature change	± 10 °C / h or less	
	Dust	0.15mg/m ³ (Equivalent to normal office level)	
Highest operation height		2000 m	

Item	SWJ-320S2	SWJ-320S4
Weight	600 kg or less	
Outside dimensions	4560 mm(W) x 1200 mm(D) x 1405 mm(H)	

Ink specifications

Item	When CS ink is used	
Supply	2L Ink bottle	
Color	Black ink Cyan ink Magenta ink Yellow ink	
Ink capacity	2000cc	
Shelf life	1 year from the date of manufacture (at room temperature)	
Storage temperature	Storage	0 to 25°C (Average daily temperature) • Be sure to keep a vessel in the airtight condition.
	Transportation	-20 to 60°C • Avoid the condition lower than -20 °C and higher than 60 °C.

Important!

- **Do not disassemble ink bottles and do not refill them with ink.**
 - **Ink could freeze if kept in a cold place for an extended period.**
 - If the ink freezes, thaw it at room temperature (25°C) spending more than 24 hours before use.
 - When aqueous ink is used, if the ink freezes, the quality is changed and the ink becomes unusable.
- Store the ink in an environment that will not freeze the ink.

Warning labels





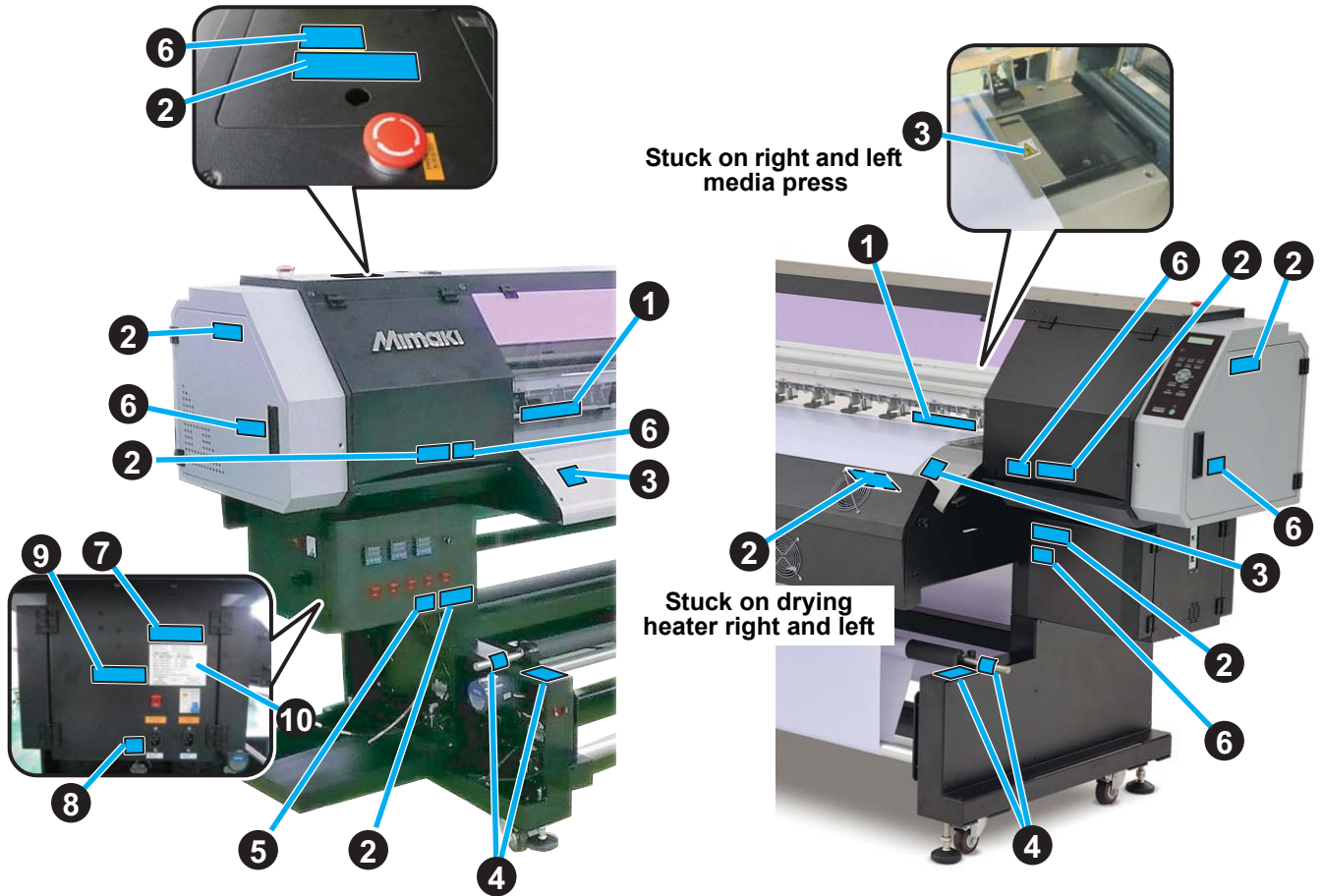

Warning labels are stuck on the machine. Be sure to fully understand the warning given on the labels. If a warning label is illegible due to stains or has come off, purchase a new one from a distributor or our sales office.

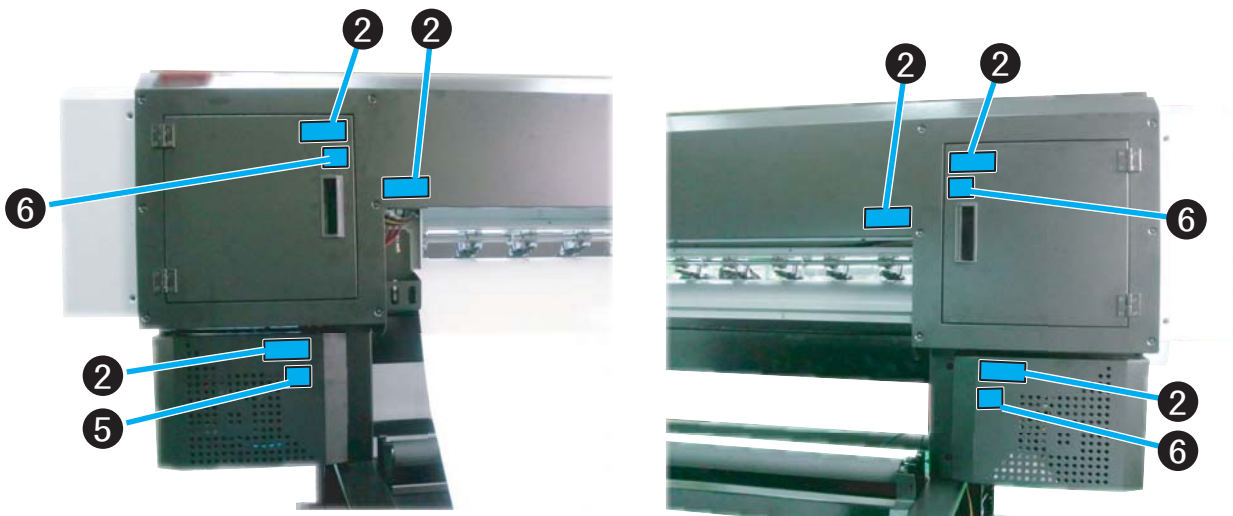
Front Side of the Machine



Rear Side of the Machine



1	M908950	 <table border="1" data-bbox="555 257 1369 376"> <tr> <th>警告</th> <th>警告</th> <th>WARNING</th> <th>WAARSCHUWING</th> <th>AVERTISSEMENT</th> </tr> <tr> <td>手指和身体请勿靠近运转部位、以免造成危险</td> <td>危険な可動部 指や体を近づけないように</td> <td>HAZARDOUS MOVING PARTS Keep fingers and other body parts away.</td> <td>GEFÄHRLICHE BEWEGLICHE TEILE Finger und andere Körperteile fernhalten.</td> <td>PIECES MOBILES DANGEREUSES Doigts et autres parties du corps sont hors de portée.</td> </tr> </table>	警告	警告	WARNING	WAARSCHUWING	AVERTISSEMENT	手指和身体请勿靠近运转部位、以免造成危险	危険な可動部 指や体を近づけないように	HAZARDOUS MOVING PARTS Keep fingers and other body parts away.	GEFÄHRLICHE BEWEGLICHE TEILE Finger und andere Körperteile fernhalten.	PIECES MOBILES DANGEREUSES Doigts et autres parties du corps sont hors de portée.												
警告	警告	WARNING	WAARSCHUWING	AVERTISSEMENT																				
手指和身体请勿靠近运转部位、以免造成危险	危険な可動部 指や体を近づけないように	HAZARDOUS MOVING PARTS Keep fingers and other body parts away.	GEFÄHRLICHE BEWEGLICHE TEILE Finger und andere Körperteile fernhalten.	PIECES MOBILES DANGEREUSES Doigts et autres parties du corps sont hors de portée.																				
2	M908922		3	M903239																				
4	M909185		5	M909436	<p style="text-align: center;">注 意</p> <p>设备维修人员必须断开 维修人员断开电源 棒电压</p> 																			
6	M909437	<p style="text-align: center;">注 意</p> <p>危险运动时 请勿靠近运动部件</p> 	7	M909438	<p>仅适用于2000m 增压机械轴螺母 仅适用于热带 切削加工用轴螺母</p>																			
8	M909254	<p style="text-align: center;">说 明</p> <p>本机有INLET1/2/3, 三部分电源组成, 在三 个电源同时切断的情况 下, 本机才属于完全没 有通电。</p> 																						
9	M909478	<p style="text-align: center;">青 崧</p> <p>崧为A级产品, 在家庭环境中, 该产品可能会产生无线电干扰。在这种情况下, 用户可能需要采取适当措施。</p> <p>This is a class A product. In a domestic environment, this product may cause interference in which case the user may be required to take adequate measures.</p>																						
10	M908972 (SWJ-320S4)	<table border="1" data-bbox="422 1451 801 1668"> <tr> <td>MODEL-SERIAL NO. 型号名称—制造编号</td> <td>Model-Seriennummer MODELE* DE SERIE</td> </tr> <tr> <td>SWJ-320S4</td> <td>*****</td> </tr> <tr> <td colspan="2"> 电压: 200V-240V, 2.9A, 50/60Hz INLET1 200V-240V ~, 5A, 50/60Hz INLET2 200V-240V ~, 10A, 50/60Hz INLET3 200V-240V ~, 14A, 50/60Hz </td> </tr> <tr> <td colspan="2"> MIMAKI ENGINEERING CO.,LTD. 御牧高科技股份有限公司 2182-3 Shigeno-otsu,Tomi,Nagano 389-0512 Japan Year of manufacture 年份: [] Herstellungsjahr Année de fabrication </td> </tr> <tr> <td colspan="2" style="text-align: right;"> MADE IN CHINA 中国制造 FABRIQUE AU CHINE </td> </tr> </table>	MODEL-SERIAL NO. 型号名称—制造编号	Model-Seriennummer MODELE* DE SERIE	SWJ-320S4	*****	电压: 200V-240V, 2.9A, 50/60Hz INLET1 200V-240V ~, 5A, 50/60Hz INLET2 200V-240V ~, 10A, 50/60Hz INLET3 200V-240V ~, 14A, 50/60Hz		MIMAKI ENGINEERING CO.,LTD. 御牧高科技股份有限公司 2182-3 Shigeno-otsu,Tomi,Nagano 389-0512 Japan Year of manufacture 年份: [] Herstellungsjahr Année de fabrication		MADE IN CHINA 中国制造 FABRIQUE AU CHINE		M908920 (SWJ-320S2)	<table border="1" data-bbox="1045 1451 1423 1668"> <tr> <td>MODEL-SERIAL NO. 型号名称—制造编号</td> <td>Model-Seriennummer MODELE* DE SERIE</td> </tr> <tr> <td>SWJ-320S2</td> <td>*****</td> </tr> <tr> <td colspan="2"> 电压: 200V-240V, 2.9A, 50/60Hz INLET1 200V-240V ~, 5A, 50/60Hz INLET2 200V-240V ~, 10A, 50/60Hz INLET3 200V-240V ~, 14A, 50/60Hz </td> </tr> <tr> <td colspan="2"> MIMAKI ENGINEERING CO.,LTD. 御牧高科技股份有限公司 2182-3 Shigeno-otsu,Tomi,Nagano 389-0512 Japan Year of manufacture 年份: [] Herstellungsjahr Année de fabrication </td> </tr> <tr> <td colspan="2" style="text-align: right;"> MADE IN CHINA 中国制造 FABRIQUE AU CHINE </td> </tr> </table>	MODEL-SERIAL NO. 型号名称—制造编号	Model-Seriennummer MODELE* DE SERIE	SWJ-320S2	*****	电压: 200V-240V, 2.9A, 50/60Hz INLET1 200V-240V ~, 5A, 50/60Hz INLET2 200V-240V ~, 10A, 50/60Hz INLET3 200V-240V ~, 14A, 50/60Hz		MIMAKI ENGINEERING CO.,LTD. 御牧高科技股份有限公司 2182-3 Shigeno-otsu,Tomi,Nagano 389-0512 Japan Year of manufacture 年份: [] Herstellungsjahr Année de fabrication		MADE IN CHINA 中国制造 FABRIQUE AU CHINE	
MODEL-SERIAL NO. 型号名称—制造编号	Model-Seriennummer MODELE* DE SERIE																							
SWJ-320S4	*****																							
电压: 200V-240V, 2.9A, 50/60Hz INLET1 200V-240V ~, 5A, 50/60Hz INLET2 200V-240V ~, 10A, 50/60Hz INLET3 200V-240V ~, 14A, 50/60Hz																								
MIMAKI ENGINEERING CO.,LTD. 御牧高科技股份有限公司 2182-3 Shigeno-otsu,Tomi,Nagano 389-0512 Japan Year of manufacture 年份: [] Herstellungsjahr Année de fabrication																								
MADE IN CHINA 中国制造 FABRIQUE AU CHINE																								
MODEL-SERIAL NO. 型号名称—制造编号	Model-Seriennummer MODELE* DE SERIE																							
SWJ-320S2	*****																							
电压: 200V-240V, 2.9A, 50/60Hz INLET1 200V-240V ~, 5A, 50/60Hz INLET2 200V-240V ~, 10A, 50/60Hz INLET3 200V-240V ~, 14A, 50/60Hz																								
MIMAKI ENGINEERING CO.,LTD. 御牧高科技股份有限公司 2182-3 Shigeno-otsu,Tomi,Nagano 389-0512 Japan Year of manufacture 年份: [] Herstellungsjahr Année de fabrication																								
MADE IN CHINA 中国制造 FABRIQUE AU CHINE																								

Sheet for inquiry

Use this sheet for troubles and abnormal functions of the machine.
Fill in the following necessary items, and then fax the sheet to our sales office.

Company name	
Person in charge	
Telephone number	
machine model	
Operating OS	
Machine information *1	
Error message	
Contents of inquiry	

*1. Refer to "Confirming Machine information" of "Convenient using" then fill in necessary information. (☞ P.3-22)

Function Flowchart

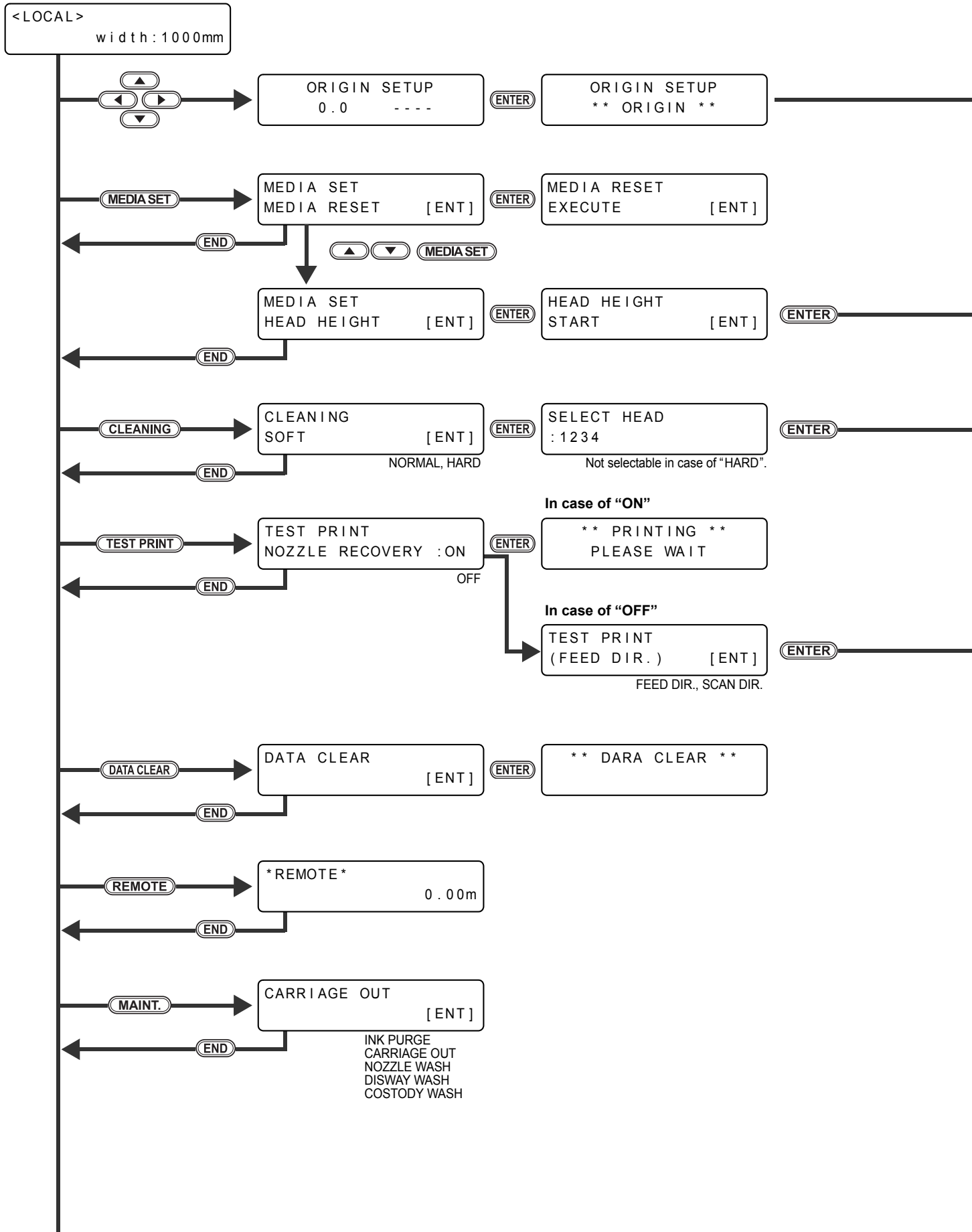

To P.6-10

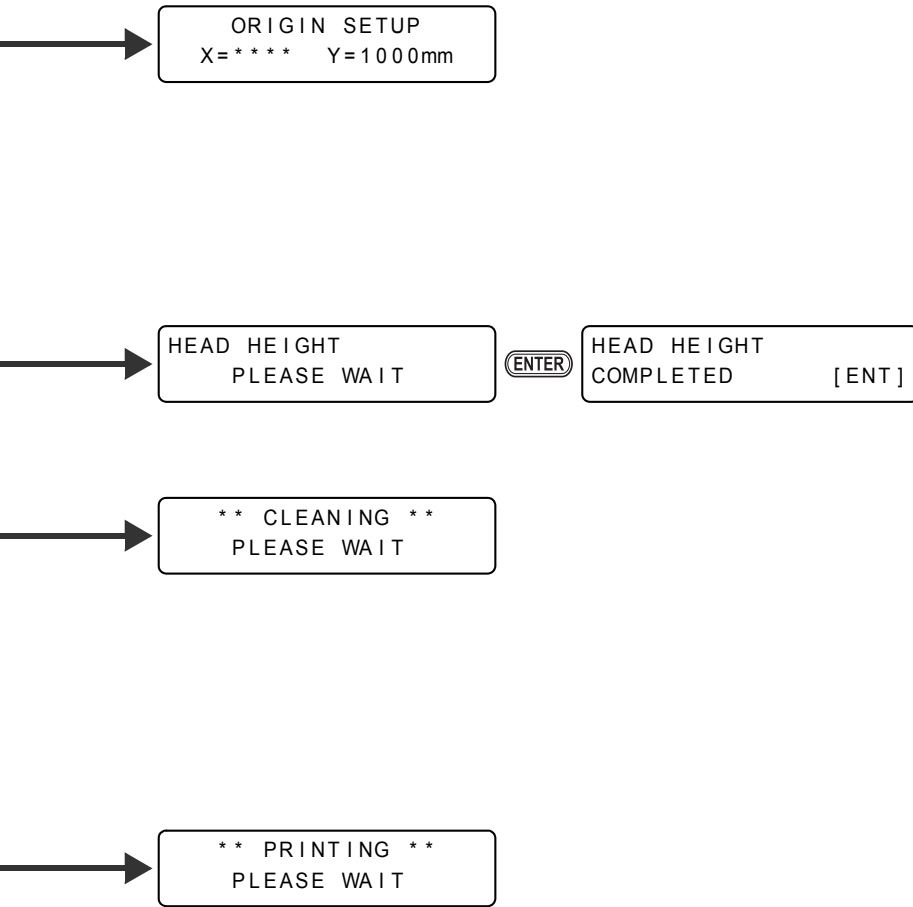

From P.6-8

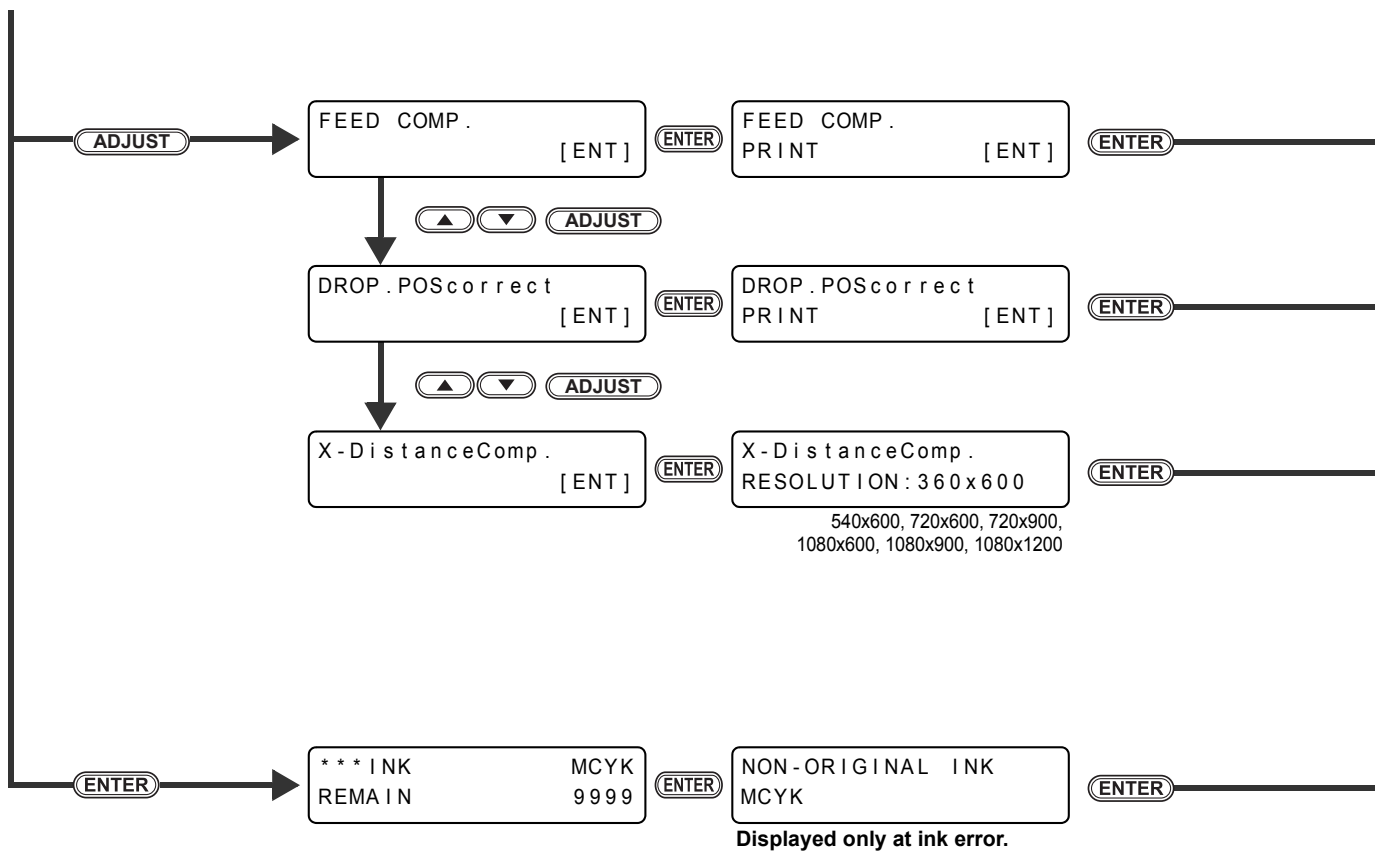

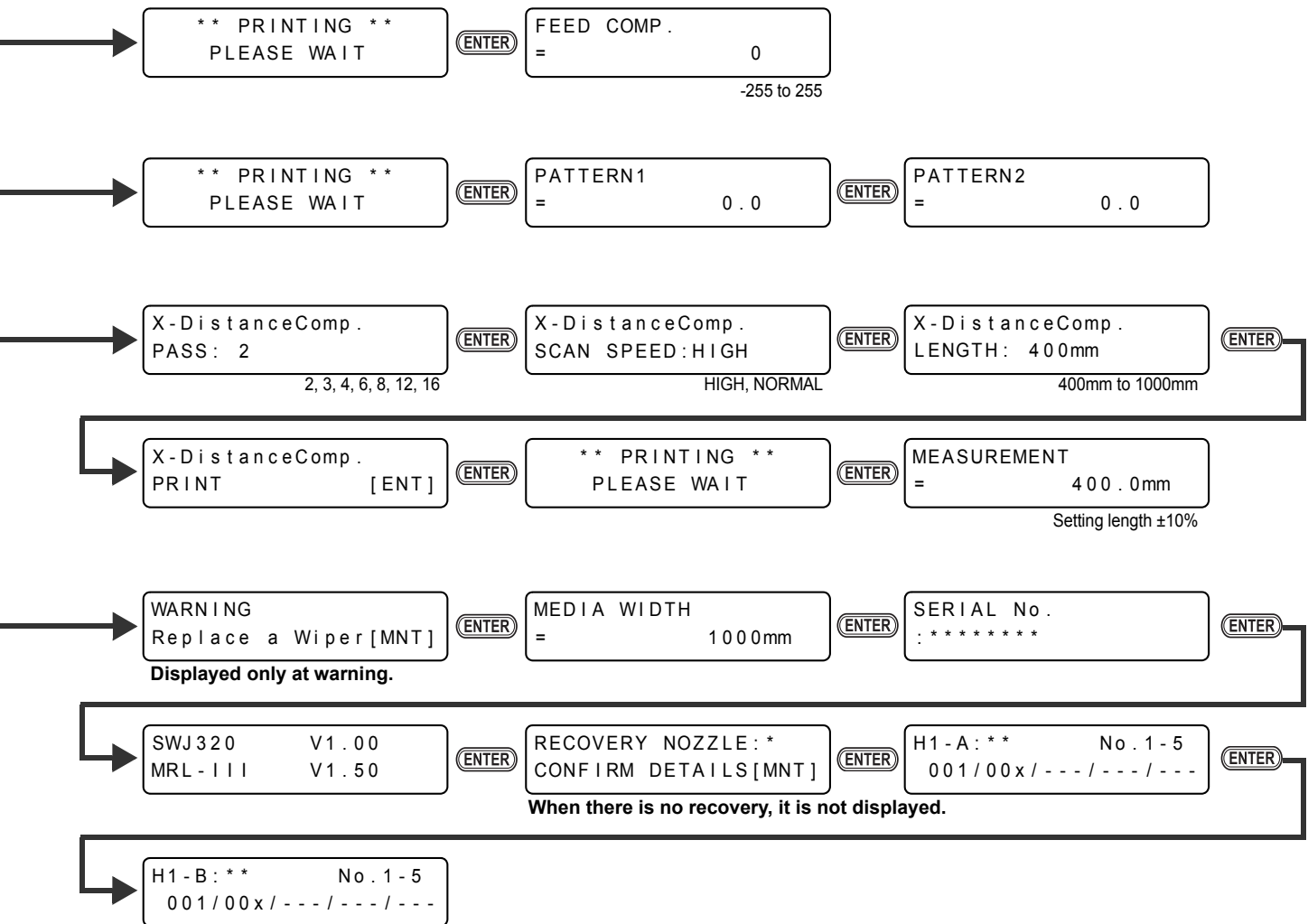

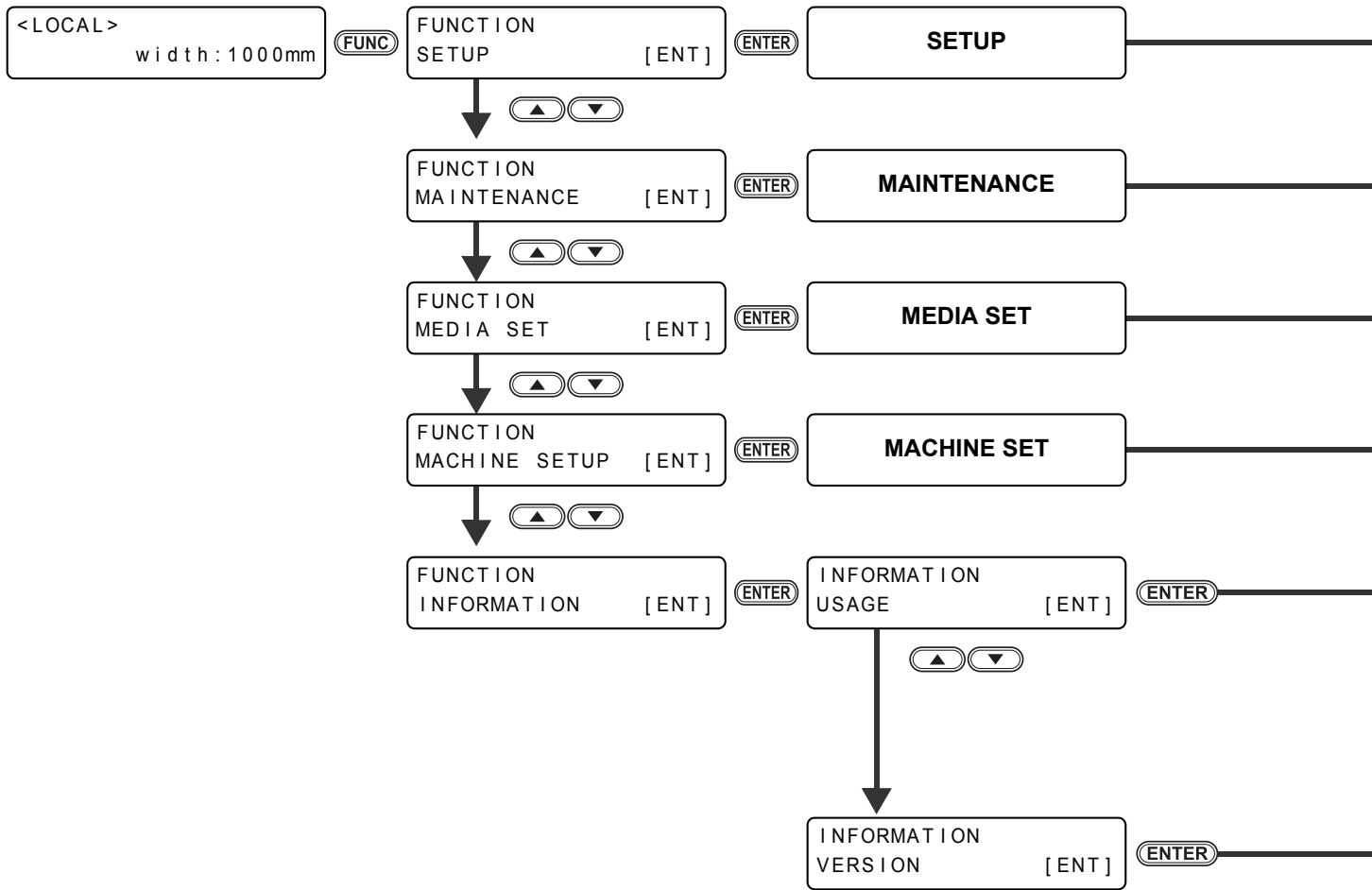

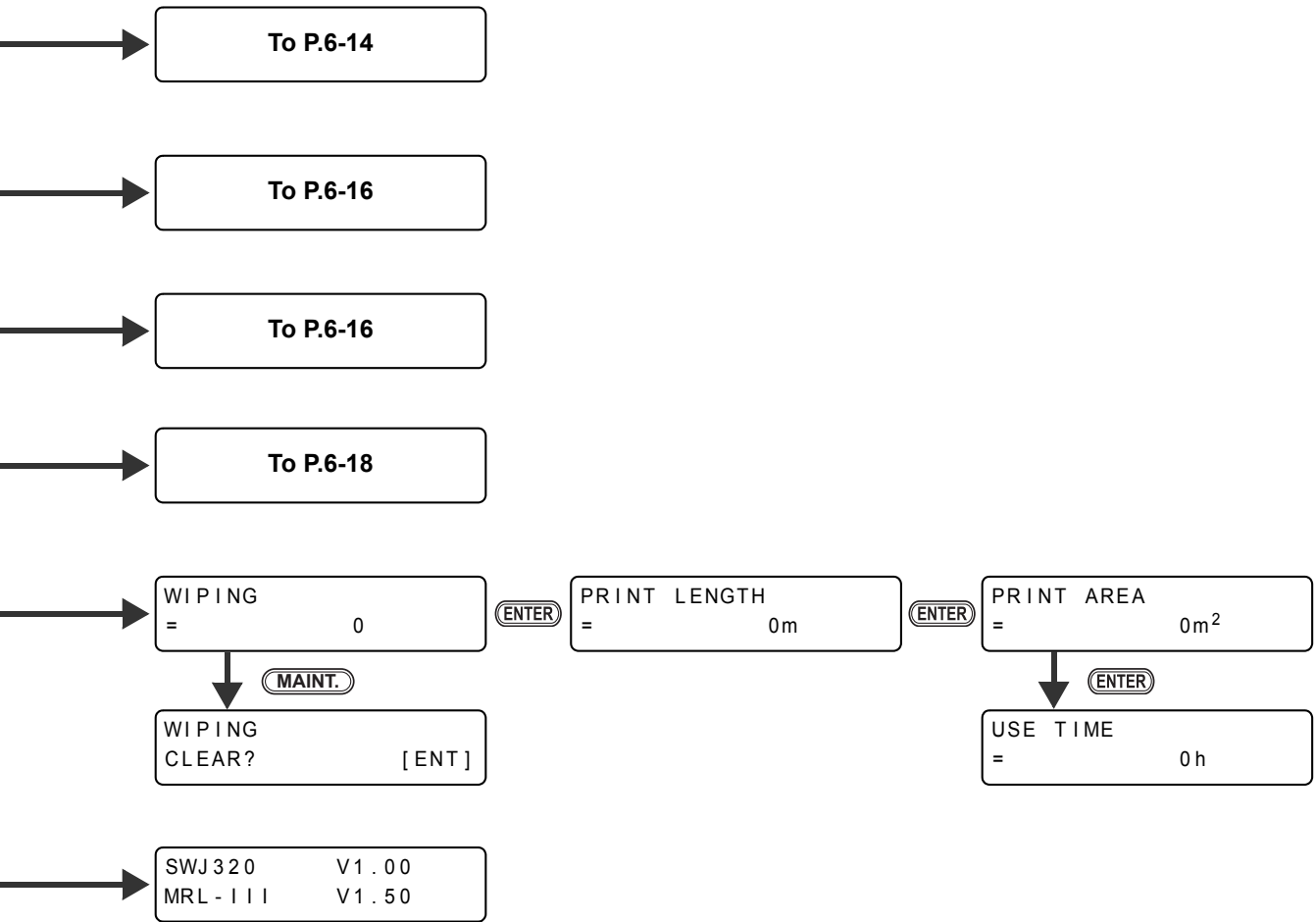

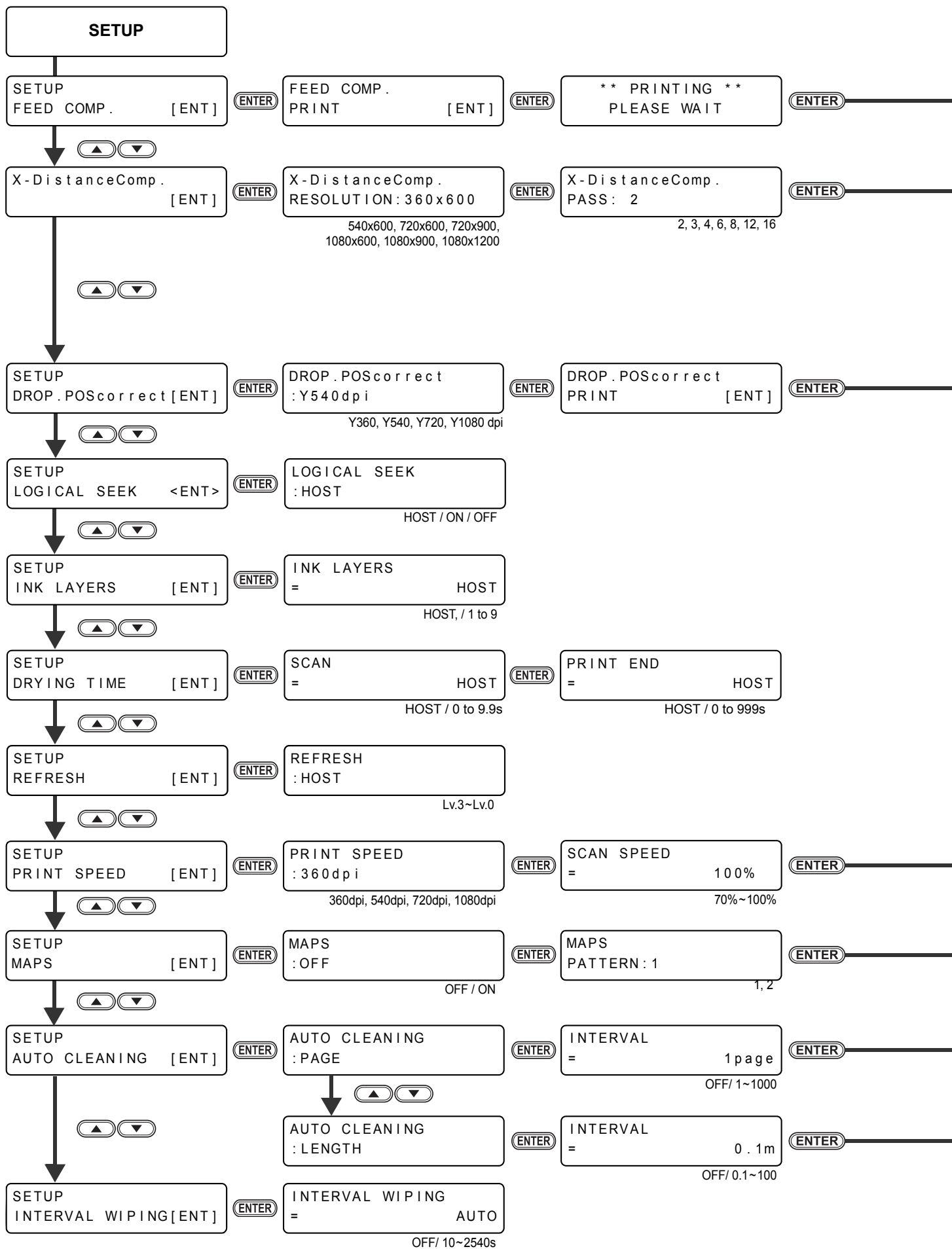

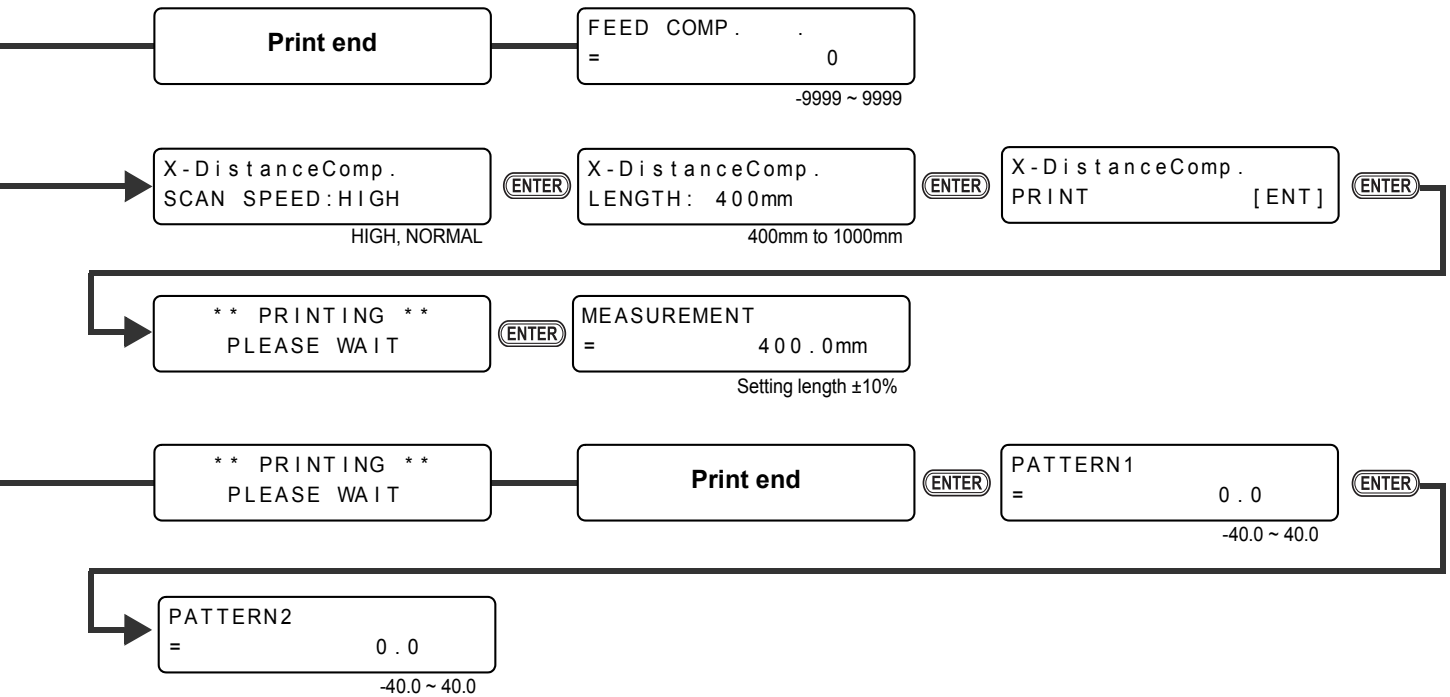

FEED SPEED
= HOST
HOST/10%~300%

PRINT SPEED ADJUST
= 0%
-50% to +50%

TYPE
: SOFT
NORMAL, HARD

TYPE
: SOFT
NORMAL, HARD

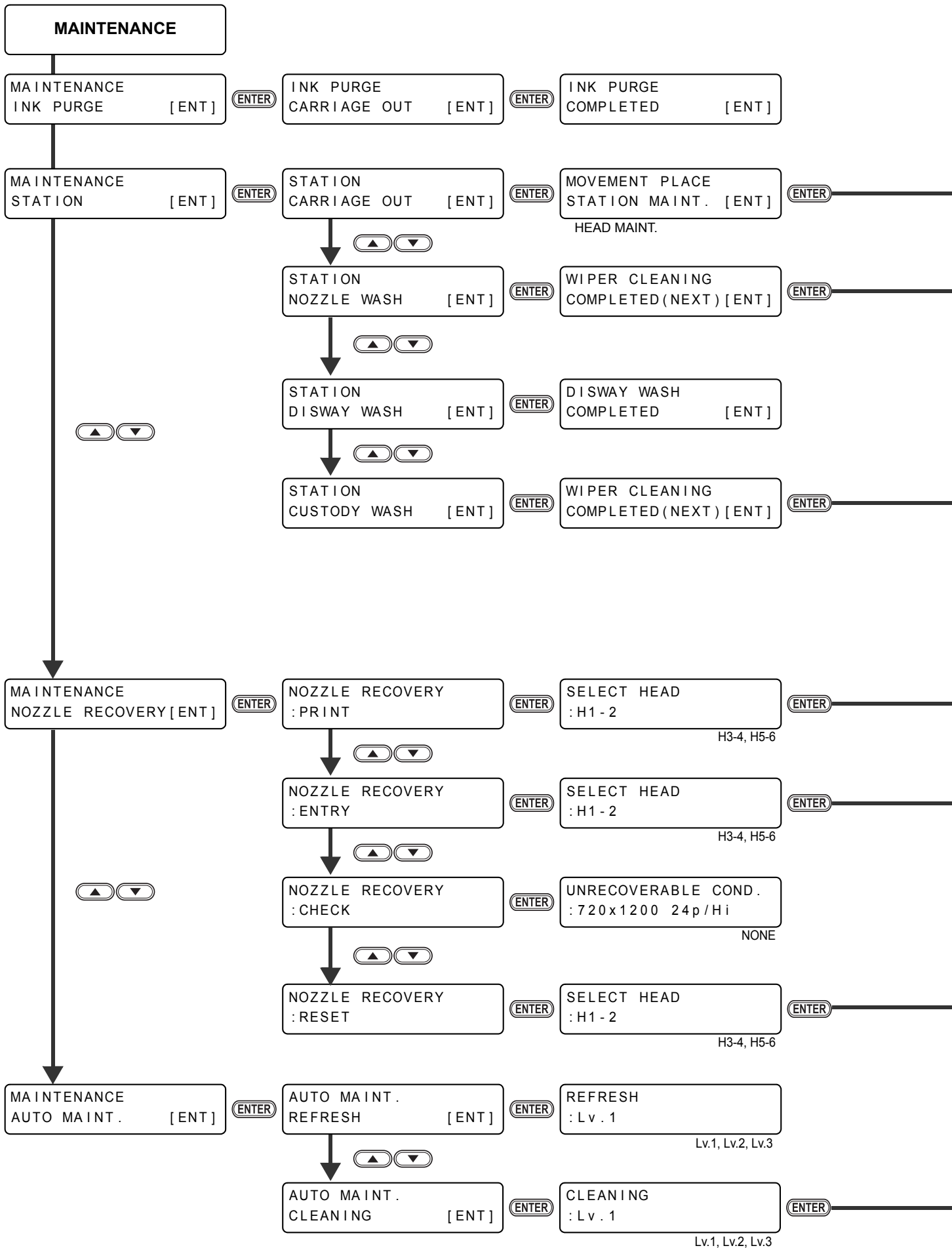

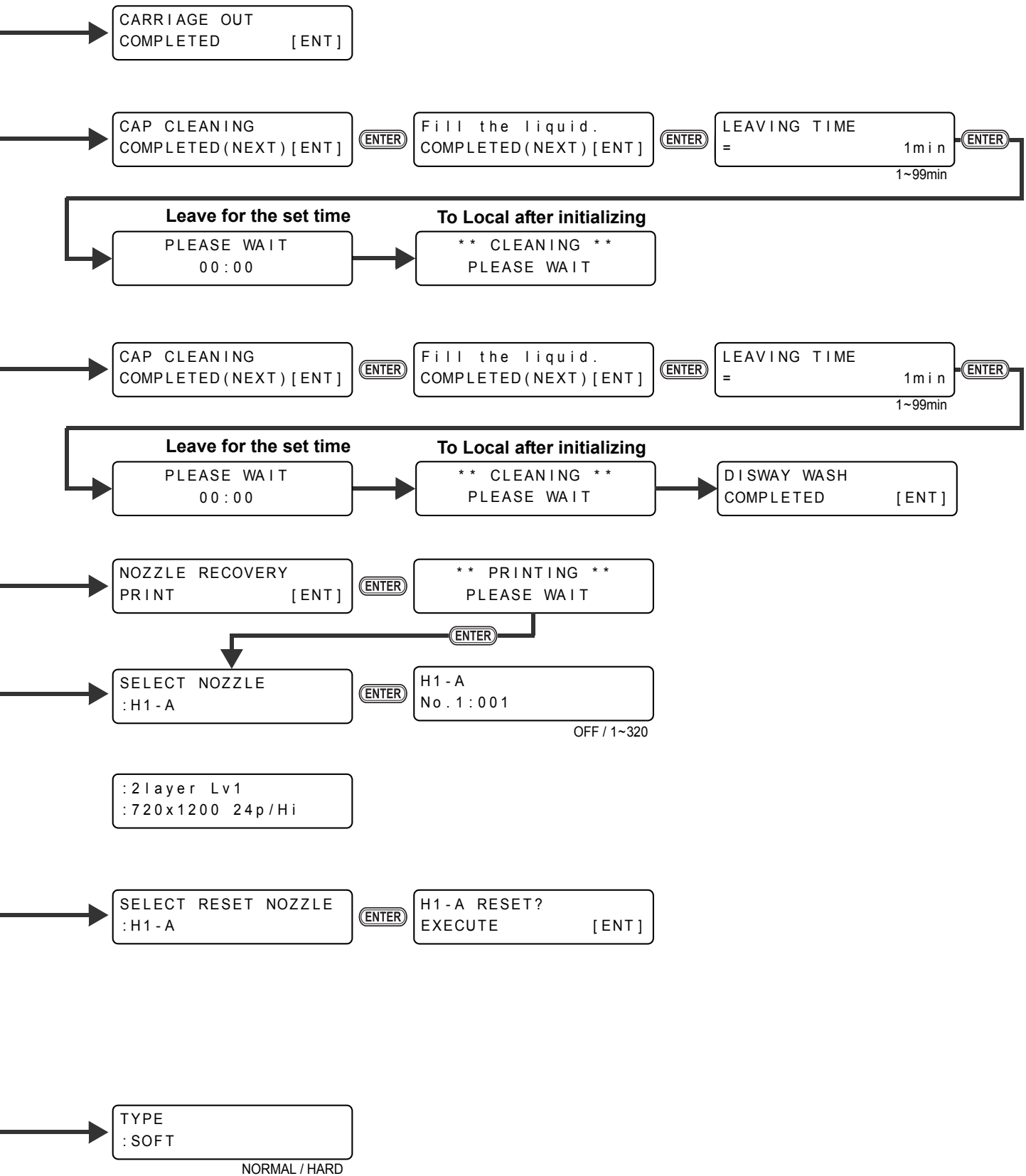

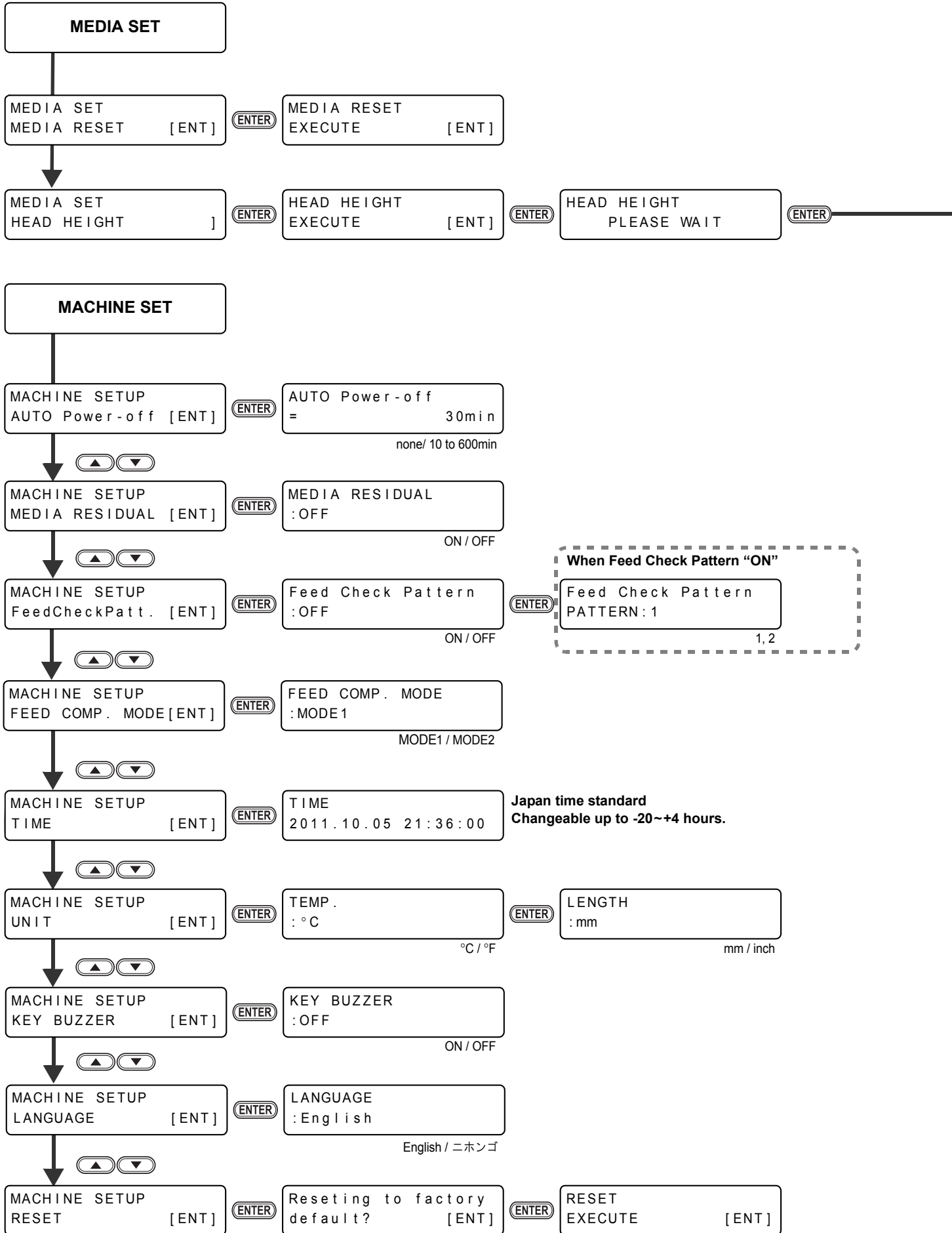

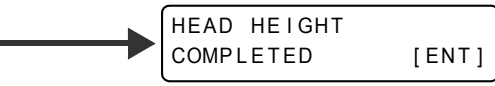

SWJ-320S Operation Manual

October, 2015

MIMAKI ENGINEERING CO.,LTD.

2182-3 Shigeno-otsu, Tomi-shi, Nagano 389-0512 JAPAN

D202342-16-14102015

